



Request for Quotation

Page One

THIS IS NOT AN ORDER

Purchasing Department | 1600 Hampton Street, Suite 606 | Columbia, SC 29208 | (803) 777-4115

Quotation must be received no later than: 10:00 AM 06 05 2019	Send Quotation to above address at Attention of: Juaquana Brookins	Solicitation Number: USC-RFQ-3499-JB	Posting Date: 05 22 2019
---	--	--	--

Please quote your lowest delivered price of the item(s) listed below. The Purchasing Department reserves the right to reject any or all quotes and to waive any or all technicalities.

All Quotes must be signed by the vendor's representative per the terms noted. Failure to comply with these instructions may result in disqualification of the Quote. Email quotes to jbrookin@mailbox.sc.edu

This solicitation conforms to Section 11-35-1550 of the SC Consolidated Procurement Code.

Vendor Name			
Vendor Address			
Phone Number		E-mail	
FEIN/SSN		SC Minority Certification #	
Printed Name		Signature	

Item	Description	Total Price	RVP	US EPP	SC EPP
1	Furnish and deliver 6' protector XL Laboratory Hood as specified herein.	\$			

Note 1: Price should include **all** costs associated with scope of work and specifications.

Note 2: All preferences must be claimed at the time of bid. Preferences are applied by line item whether the award is to be made by line item or lot. If you request a preference, you are certifying that your offer qualifies for the preference you have claimed. See provisions for preferences in Section II.B.

Note: The commodity preferences do not apply to a bid for an item of work by the bidder if the annual price of the bidder's work exceeds \$50,000 or the total potential price of the bidder's work exceeds \$500,000. [11-35-1524(E) (3)]

TERMS AND CONDITIONS

All amendments to and interpretations of this Request for Quotations shall be in writing. The procurement officer shall not be legally bound by any amendment or interpretation that is not in writing.

Any contract entered into by the University of South Carolina or its agencies resulting from this solicitation shall be subject to cancellation at the end of any fiscal or appropriated year unless otherwise provided by law.

Unit prices will govern over extended prices unless otherwise stated. Quoted prices must remain firm for a period of thirty (30) days after the RFQ deadline.

Award will be made in accordance with 11-35-1550 of the South Carolina Consolidated Procurement Code.

Award will be made to one contractor by item.

All materials and products offered must be guaranteed to meet and comply with the requirements of all specifications, terms, and conditions indicated in this solicitation.

The University reserves the right to: (1) reject any and all quotations and to cancel the solicitation; (2) waive any and all technicalities; (3) reject any quotation in which the delivery time indicated is of substantial length to cause disruption and/or delay in operation for which the item(s) is/are intended; (4) reject ambiguous quotations which are uncertain as to terms, delivery, quantity, or compliance with specifications.

Contractor assumes sole responsibility and shall hold harmless the University of South Carolina, its directors, officers, employees, and agents from and against any and all claims, actions, or liabilities of any nature which may be asserted against them by third parties in connection with the performance of the successful bidder, its directors, officers, employees, and agents under this agreement. The University of South Carolina agrees to accept responsibility for claims, actions, or liabilities resulting from negligent acts of its employees occurring within the scope of their employment which may be asserted against them by third parties in connection with the performance of the University of South Carolina, its members, directors, officers, employees, and agents under this agreement.

Contractor agrees not to refer to award of this contract in commercial advertising in such a manner to state or imply that the products or service provided are endorsed or preferred by the user.

Upon award of a contract under this solicitation, the person, partnership, association, or corporation to whom the award is made must comply with the laws of South Carolina that require such person or entity to be authorized and/or licensed to do business in this State. Notwithstanding the fact that applicable statutes may be exempt or exclude the successful offeror from requirements that it be authorized and/or licensed to do business in this State, by submission of this signed quote, the quoter agrees to subject itself to the jurisdiction and process of the courts of the State of South Carolina as to all matters and disputes arising or to arise under the contract and the performance thereof, including any questions as to the liability for taxes, licenses, or fees levied by the State.

Payment will be made in accordance with 11-35-45 of the South Carolina Consolidated Procurement Code and Disbursement Regulations. Delay in receiving invoices, as well as errors and omissions on the invoices, will be considered just cause for withholding payment without losing discount privileges. The University reserves the right to withhold payment or make such deductions as may be necessary to protect the

University from loss or damage because of defective work, claims, damages, or to pay for repair of correction of materials furnished hereunder.

QUESTIONS FROM OFFERORS

Any prospective offeror desiring an explanation or interpretation of the solicitation, drawings, specifications, etc., must request it in writing. Questions must be received by the Procurement Officer no later than **May 29, 2019 at 10:00 AM EST**. Submit any communication regarding this solicitation to the Procurement Officer and include the solicitation number and description. Oral explanations or instructions will not be binding. Any information given to a prospective offeror concerning this solicitation will be furnished to all other prospective offerors as an Amendment to the solicitation if that information is necessary for submitting offers or if the lack thereof would be prejudicial to other prospective offerors. The State seeks to permit maximum practicable competition. Offerors are urged to advise the Procurement Officer as soon as possible regarding any aspect of this procurement, including this solicitations, that unnecessarily or inappropriately limits full and open competition.

Via email only jbrookin@mailbox.sc.edu
Subject: USC-RFQ-3499-JB

VENDOR IDENTIFICATION

The University must have your Federal ID Number (company) or Social Security Number (individual) before processing any invoices for payment. Failure to provide this information will result in delay of payments until this information is received. Please include this information with your quote.

CONTRACTOR'S OBLIGATION – GENERAL (JAN 2006)

The contractor shall provide and pay for all materials, tools, equipment, labor and professional and non-professional services, and shall perform all other acts and supply all other things necessary, to fully and properly perform and complete the work. The contractor must act as the prime contractor and assume full responsibility for any subcontractor's performance. The contractor will be considered the sole point of contact with regard to all situations, including payment of all charges and the meeting of all other requirements.

PREFERENCES – A NOTICE TO VENDORS (SEP 2009)

On June 16, 2009, the South Carolina General Assembly rewrote the law governing preferences available to in-state vendors, vendors using in-state subcontractors, and vendors selling in-state or US end products. This law appears in Section 11-35-1524 of the South Carolina Code of Laws. A summary of the new preferences is available at www.procurement.sc.gov/preferences. **ALL THE PREFERENCES MUST BE CLAIMED AND ARE APPLIED BY LINE ITEM, REGARDLESS OF WHETHER AWARD IS MADE BY ITEM OR LOT. VENDORS ARE CAUTIONED TO CAREFULLY REVIEW THE STATUTE BEFORE CLAIMING ANY PREFERENCES. THE REQUIREMENTS TO QUALIFY HAVE CHANGED. IF YOU REQUEST A PREFERENCE, YOU ARE CERTIFYING THAT YOUR OFFER QUALIFIES FOR THE PREFERENCE YOU'VE CLAIMED. IMPROPERLY REQUESTING A PREFERENCE CAN HAVE SERIOUS CONSEQUENCES. [11-35-1524(E)(4)&(6)]**

PREFERENCES – RESIDENT VENDOR PREFERENCE (SEP 2009)

To qualify for the RVP, you must maintain an office in this state. An office is a nonmobile place for the regular transaction of business or performance of a particular service which has been operated as such by the bidder for at least one year before the bid opening and during that year the place has been staffed for at least fifty weeks by at least two employees for at least thirty five hours a week each. In addition, you must either: (1) maintain at a location in South Carolina at the time of the bid an inventory of expendable items which are representative of the general type of commodities for which the award will be made and which have a minimum total value, based on the bid price, equal to the lesser of fifty thousand dollars [\$50,000] or the annual amount of the contract; or (2) be a manufacturer headquartered and having an

annual payroll of at least one million dollars in South Carolina and the end product being sold is either made or processed from raw materials into a finished end product by that manufacturer or its affiliate (as defined in Section 1563 of the Internal Revenue Code).

PREFERENCES – SC/US END PRODUCT (SEP 2009)

Section 11-35-1524 provides a preference to vendors offering South Carolina end-products or US end-products, if those products are made, manufactured, or grown in SC or the US, respectively. An end-product is the tangible project identified for acquisition in this solicitation, including all component parts in final form and ready for the use intended. The terms "made," "manufactured," and "grown" are defined by Section 11-35-1524(A). By signing your offer and checking the appropriate space(s) provided and identified on the bid schedule, you certify that the end-product(s) is either made, manufactured or grown in South Carolina, or other states of the United States, as applicable. Preference will be applied as required by law. Post award substitutions are prohibited. See "Substitutions Prohibited - End Product Preferences (Sep 2009)" provision.

PREFERENCES – BID SCHEDULE

All preferences must be claimed by initialing in the space provided in the bid schedule. Preferences are applied by line item whether the award is to be made by line item or lot. If you request a preference, you are certifying that your offer qualifies for the preference you have claimed. If you qualify for a preference but do not request it, you are not entitled to receive preference applications per 11-35-1524.

RVP = Resident Vendor Preference

USEP = United States End Product Preference

SCEP = South Carolina End Product Preference

SUBSTITUTIONS PROHIBITED – END PRODUCT PREFERENCES (SEP 2009)

If you receive the award as a result of the South Carolina end product or United States end product preference, you may not substitute a nonqualifying end product for a qualified end product. If you violate this provision, the State may terminate your contract for cause and you may be debarred. In addition, you shall pay to the State an amount equal to twice the difference between the price paid by the State and your evaluated price for the item for which you delivered a substitute. [11-35-1524(B)(4)]

LICENSES AND PERMITS (JAN 2006)

During the term of the contract, the Contractor shall be responsible for obtaining, and maintaining in good standing, all licenses (including professional licenses, if any), permits, inspections and related fees for each or any such licenses, permits and /or inspections required by the State, county, city or other government entity or unit to accomplish the work specified in this solicitation and the contract.

RELATIONSHIP OF THE PARTIES (JAN 2006)

Neither party is an employee, agent, partner, or joint venture of the other. Neither party has the right or ability to bind the other to any agreement with a third party or to incur any obligation or liability on behalf of the other party.

MATERIAL AND WORKMANSHIP (JAN 2006)

Unless otherwise specifically provided in this contract, all equipment, material, and articles incorporated in the work covered by this contract are to be of the most suitable grade for the purpose intended.

SHIPPING / RISK OF LOSS

FOB Destination. Destination is the shipping dock of the University of South Carolina's designated receiving site, or other location, as specified herein.

DEFAULT AND TERMINATION

The University may terminate this contract, or any part hereof, for cause in the event of any default by the contractor, or if the contractor fails to comply with any contract terms and conditions, or fails to provide the state, upon request, with adequate assurances of future performance. In the event of termination for cause, the University will not be liable to the contractor for any amount for supplies or services not accepted, and the contractor will be liable to the University for any and all rights and remedies provided by law. If it is determined that the University improperly terminated this contract for default, such termination shall be deemed a termination for convenience. In case of default by the contractor, the University reserves the right to purchase any or all items in default in the open market, charging the contractor with any additional costs. The defaulting contractor shall not be considered a responsible bidder until the assessed charge has been satisfied. In the event that this contract is terminated or cancelled upon request and for the convenience of the University, it may negotiate reasonable termination costs, if applicable.

PROTECTION OF HUMAN HEALTH AND THE ENVIRONMENT

The University of South Carolina requires all contractual activities to be performed in a manner that is consistent with all applicable federal, state, and local laws, regulations, rules, rulings, and ordinances concerning "protection of human health and the environment." These include, but are not limited to: the Occupational Safety and Health Act, the Environmental Protection Act, and the South Carolina Hazardous Waste Management Act.

DELIVERY / PERFORMANCE LOCATION – PURCHASE ORDER

After award, all deliveries shall be made and all services provided to the location specified by the University of South Carolina in its purchase order.

HIPAA LAW

The Contractor agrees that to the extent that some or all of the activities within the scope of this Contract are subject to the Health Insurance Portability Accountability Act of 1996, P.L. 104-91, as amended ("HIPAA"), or its implementing regulations, it will comply with the HIPAA requirements and will execute such agreements and practices as the University of South Carolina may require to ensure compliance. Additional information may be viewed at: <http://www.sa.sc.edu/shs/hipaa/>

OPEN TRADE REPRESENTATION (JUN 2015)

By submitting an Offer, Offeror represents that Offeror is not currently engaged in the boycott of a person or an entity based in or doing business with a jurisdiction with whom South Carolina can enjoy open trade, as defined in SC Code Section 11-35-5300.

OPEN TRADE (JUN 2015)

During the contract term, including any renewals or extensions, Contractor will not engage in the boycott of a person or an entity based in or doing business with a jurisdiction with whom South Carolina can enjoy open trade, as defined in SC Code Section 11-35-5300.

DRUG FREE WORK PLACE CERTIFICATION

By **submitting** a Quote, Contractor certifies that, if awarded a contract, Contractor will comply with all applicable provisions of The Drug-free Workplace Act, Title 44, Chapter 107 of the South Carolina Code of Laws, as amended.

RESTRICTIONS ON PRESENTING TERMS OF USE OR OFFERING ADDITIONAL SERVICES (FEB 2015)

(a) Citizens, as well as public employees (acting in their individual capacity), should not be unnecessarily required to agree to or provide consent to policies or contractual terms in order to access services

acquired by the government pursuant to this contract (hereinafter “applicable services”) or, in the case of public employees, to perform their job duties; accordingly, in performing the work, contractor shall not require or invite any citizen or public employee to agree to or provide consent to any end user contract, privacy policy, or other terms of use (hereinafter “terms of use”) not previously approved in writing by the procurement officer. Contractor agrees that any terms of use regarding applicable services are void and of no effect.

(b) Unless expressly provided in the solicitation, public contracts are not intended to provide contractors an opportunity to market additional products and services; accordingly, in performing the work, contractor shall not – for itself or on behalf of any third party – offer citizens or public employees (other than the procurement officer) any additional products or services not required by the contract.

(c) Any reference to contractor in items (a) or (b) also includes any subcontractor at any tier. Contractor is responsible for compliance with these obligations by any person or entity that contractor authorizes to take any action related to the work.

(d) Any violation of this clause is a material breach of contract. The parties acknowledge the difficulties inherent in determining the damage from any breach of these restrictions. Contractor shall pay the state liquidated damages of \$1,000 for each contact with a citizen or end user that violates this restriction.

COMPLIANCE WITH LAWS (JAN 2006)

During the term of the contract, contractor shall comply with all applicable provisions of laws, codes, ordinances, rules, regulations, and tariffs.

SCOPE OF WORK / SPECIFICATIONS

To furnish and deliver 6' protector XL Laboratory Hood, see attachment A for specifications.

UofSC will provide all HVAC work in connecting the hood.

MINORITY PARTICIPATION (JAN 2006)

Is the bidder a South Carolina Certified Minority Business? Yes NO

Is the bidder a Minority Business certified by another governmental entity? Yes NO

If so, please list the certifying governmental entity: _____

Will any of the work under this contract be performed by a SC certified Minority Business as a subcontractor? Yes NO

If so, what percentage of the total value of the contract will be performed by a SC certified Minority Business as a subcontractor? Yes NO

Will any of the work under this contract be performed by a minority business certified by another governmental entity as a subcontractor? Yes NO

If so, what percentage of the total value of the contract will be performed by a minority business certified by another governmental entity as a subcontractor? Yes NO

If a certified Minority Business is participating in this contract, please indicate all categories for which the Business is certified:

- Traditional minority
- Traditional minority, but female
- Women (Caucasian females)
- Hispanic minorities
- DOT referral (Traditional minority)
- DOT referral (Caucasian female)
- Temporary certification
- SBA 8 (a) certification referral
- Other minorities (Native American, Asian, etc.)

(If more than one minority contractor will be utilized in the performance of this contract, please provide the information above for each minority business.)

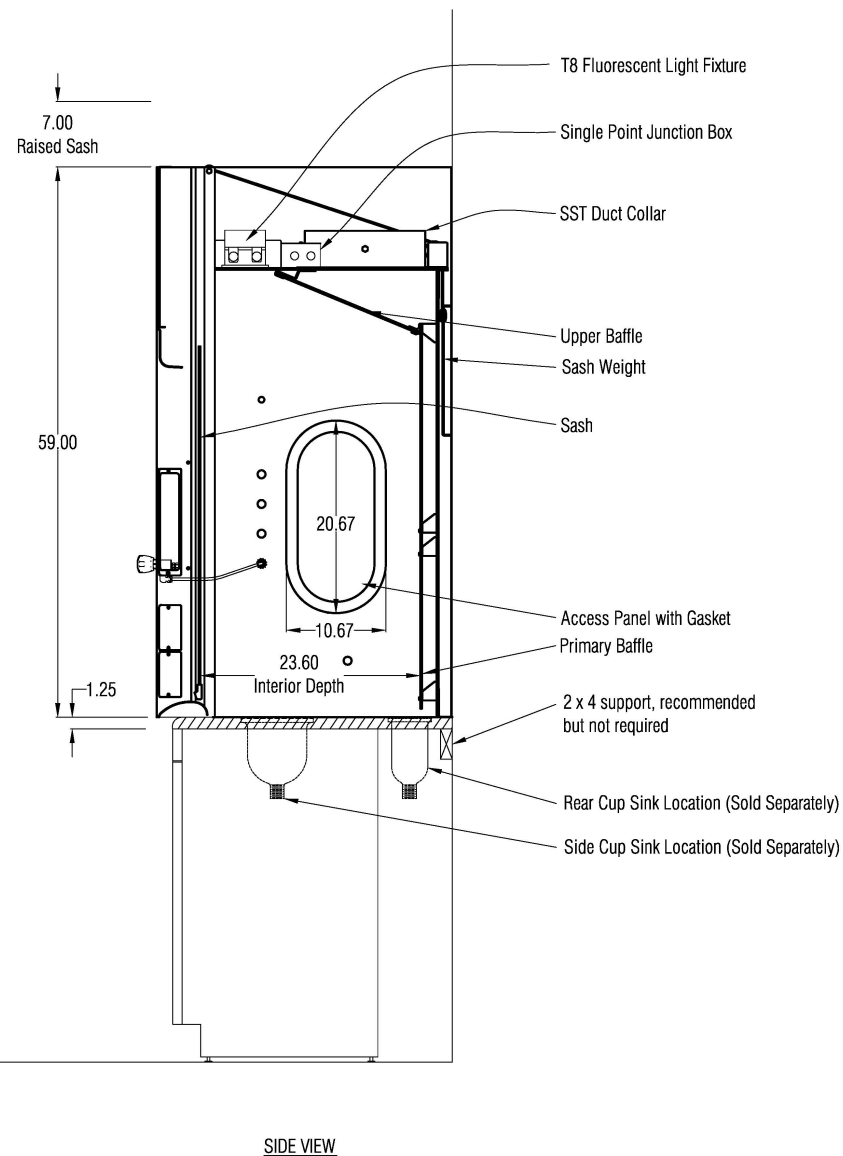
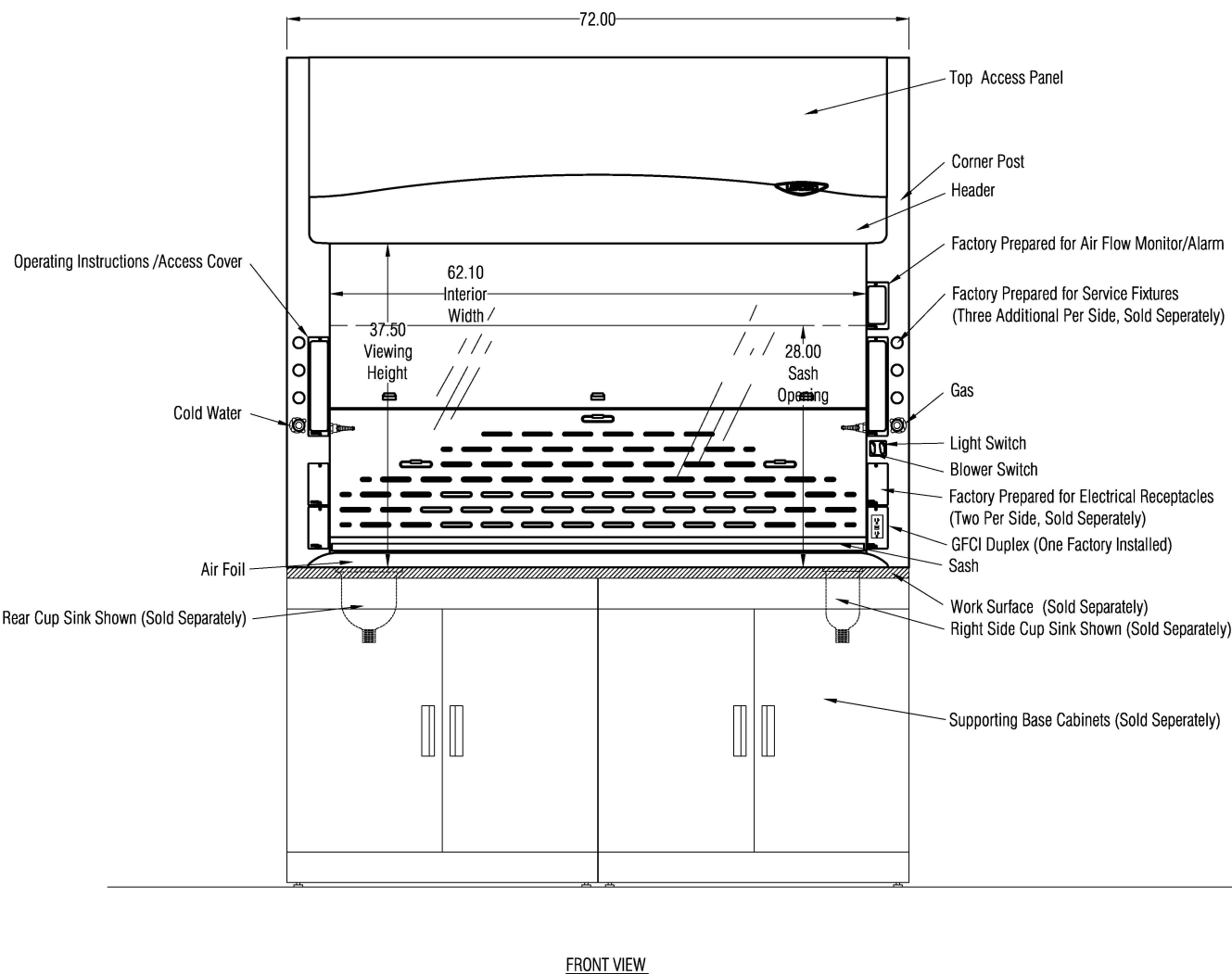
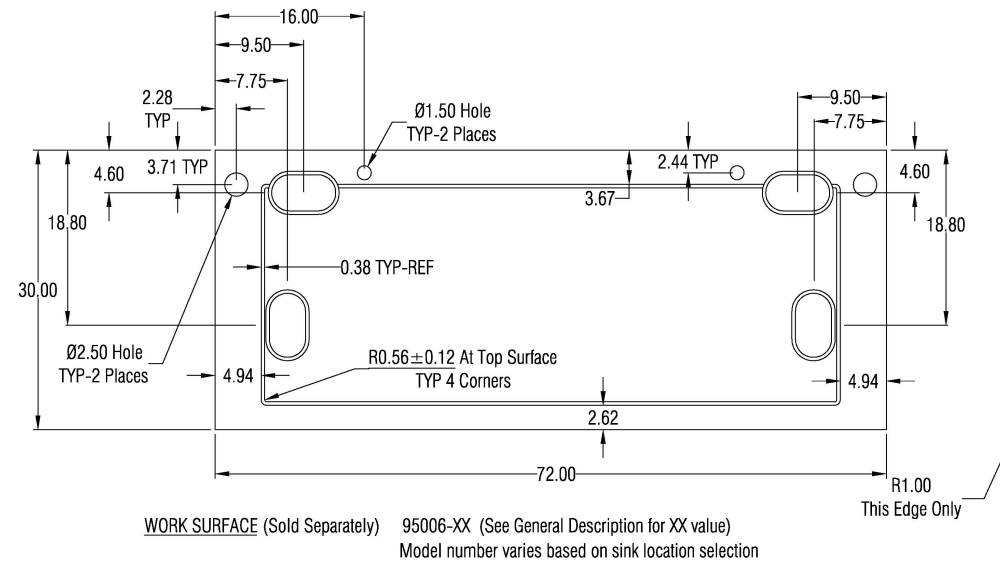
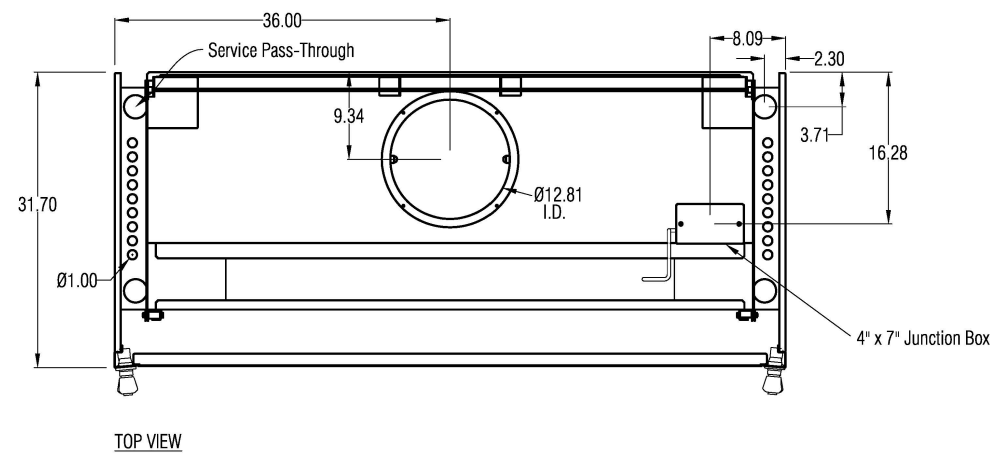

GENERAL DESCRIPTION

6' Protector XL Laboratory Hood, 31.7" Exterior Model: 111 60 0002

Exterior Superstructure

* Double Wall Construction * 18 Gauge Cold Rolled Steel

Interior Superstructure

* Galvanized Steel (standard)

Left / Right Facia:

* Powder Coated Steel * Color: Glacier White

Liner Material

* Molded Composite Sheet

Side Panels

* Both Sides * Removable * Color: Glacier White

Baffles

* Molded Composite Sheet

Interior Access Panels

* Right and Left Sides

* Gasket Provided

Corner Post with Access Covers

* Right and Left Sides

* 18 Gauge Cold Rolled Steel

Air Foil

* Cold Rolled Steel * Powder Coat Finish

Sash

* Vertical Travel

* Tempered Safety Glass

* Counter Weighted and Balanced

* Pulley System

Electrical Fixtures

* Fluorescent Light and Tubes w/ Switch

* Duplex, 115VAC / 60HZ / 20A/ GFCI

Alarm / Monitor

* None Provided

Wiring

* Fume Hood Wired at Factory

* Electrical Connection made inside 4x7 Junction Box

* 100-115V, 50/60 Hz

VAV Preparations

* None Requested

Service Fixtures

* Labconco * Color-Coded Hooded Handle * Front Loading

* Parts included to convert standard fixtures to Vac or Air

Symbol	Service	Color
CW	Cold Water	Green
Gas	Gas	Blue
Air	Compressed Air	Orange
Vac	Vacuum	Yellow

Plumbing

* Connections Made with Swagelock Compression Fittings

* Final connection by others

* Pre-Piped to Valve Outlet

* Standard Water Piping is 1/4" Copper Tubing

* Air and Vac Piping is 1/4" Copper Tubing

* Standard Gas Piping is 1/4" Brass Tubing

Face velocity (FPM)		Volumetric Rate (CFM) @ Static Pressure (inches H2O)
Sash at full open	Sash at 60%	
100	160	1180, 0.46"
80	128	945, 0.29"
60	96	710, 0.17"
50*	80	590, 0.11"
40*	64	470, 0.07"

***There is not a written standard that would suggest a design face velocity below 60 fpm. This data is for informational purposes only.**

Work Surface (Sold Separately)

* Black Epoxy Work Surface, Model 95006-XX (See below for XX)

* No cup sink # 00

* Cup Sink Right Rear # 01

* Cup Sink Right Side # 02

* Cup Sink Left Rear # 10

* Cup Sink Left Side # 20

* Cup Sink Left and Right Rear # 11

* Cup Sink Left and Right Side # 22

Cup Sink (Sold Separately)

* 4005200

Required Accessories (Sold Separately)

* Remote Blower

* Supporting Base

Assembly and Crating

* Pre-Assembled

* Palletized

SCALE: Scaled to fit

FUME HOODS for:



Labconco Corporation
8811 Prospect Avenue
Kansas City, Mo. 64132-2686
(800) 821-5255
www.labconco.com

No.	Date

Date: 10-31-2012

Drawing # 111 60 0002

Drawn By: Luke Savage

Checked By:

Approved By:

Sheet No.

LCC Order Number:

Log Number: