



**2KM Architects, Inc.**  
529 Greene Street  
Augusta, GA 30901  
ph. 706.736-3333  
fx. 706.736-7100

## ADDENDUM #1

<b>DATE:</b>	<b>APRIL 18, 2018</b>
<b>PROJECT:</b>	<b>USC-AIKEN RUTH PATRICK CLASSROOM RENOVATION University of South Carolina at Aiken Aiken, South Carolina</b>
<b>PROJECT NUMBER:</b>	<b>PROJECT 50003278; 2KM #2017-17</b>

### **Part 1 – Pre-Bid RFI Q & A:**

1.101 **RFI #1:** Could either USG MARS88138 or USG Halcyon 98221 be a substitute for the ceiling tiles?

**Response: Yes, the substitute tiles are acceptable.**

1.101 **RFI #2:** Can Finelite and H.E. Williams be substitute light fixture manufactures?

**Response: Yes, the substitute manufacturers are acceptable.**

1.102 **RFI #3:** Could you tell me how high the walls are we are building in classroom 203 are? Not the one on top of the CMU Wall.

**Response: The finished height of the wall in both classrooms is ~ 8'-0" above existing CMU wall. Brace to roof structure.**

### **Part 2 – Specifications:**

- 1.201 Reference Bid Requirements, Invitation to Bid, second paragraph, Pre-Bid Conference.
- a. The following are made a part of the Contract Documents:
    1. See attached "***Sign-in Log***" for attendance at Pre-bid Conference.
    2. See attached "***Meeting Notes***" from Pre-bid Conference.

### **Part 3 – Drawings:**

- 1.301 Reference Drawing A1.1 First Floor Plan - New Work Plan:
- a. **ADD:** Construction Note call-outs 9.512, 9.910 and 26.510 in Work Area/Receptionist 104.
- 1.302 Reference Drawing A1.2 Second Floor Plan Add Alt. #1:
- a. **ADD:** Modify Construction Note 9.912 "Prime and paint GPDW, door frames & trim, clean all paint surfaces w/ synthetic tsp solution for new paint surface preparation.

**END OF ADDENDUM #1**

SUBMITTED BY:

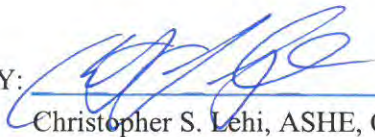

Christopher S. Lehi, ASHE, CSI  
Project Manager / Contract Administrator

APPROVED BY:



Robert L. Mauldin, NCARB, AIA  
Principal Architect, GA-RA-005958

Enclosures:

Pre-Bid Meeting Sign-in Sheet

Pre-Bid Meeting Agenda

Pre-Bid Meeting Report

Drawing ADD#1-A1.1

Drawing ADD#1-A1.2a



**PRE-BID CONFERENCE AGENDA  
RUTH PATRICK CLASSROOM RENOVATIONS  
UNIVERSITY OF SOUTH CAROLINA - AIKEN  
AIKEN, SOUTH CAROLINA  
PROJECT NUMBER 2KM#: 2017-17**

**Date:** *April 10, 2018*  
**Time:** *10:00 A.m.*

**Location:** *Pickens-Salley House, Conference Room  
471 University Parkway  
Aiken, SC 29801*

Attendees: (See sign-in sheet)

**1. Sign-in:**

- a. Sign and provide contact information.
- b. Request all parties sign-in with Full Name, Title, Company Name, Phone Number, Fax Number and E-mail.

**2. Introductions:**

- a. A/E and Owner.
- b. Facility Representatives.
- c. All attendees.

**3. General Project Overview:**

- a. Building & use.
  - 1) Facility type and general project overview:
    - a) Classroom Building
  - 2) Limited demolition.
  - 3) Install new interior sound attenuated wall, door & wall finishes.
  - 4) Revise HVAC ductwork to supply separated space.
  - 5) New LED Lighting fixtures.
- c. Schedule:
  - 1) Bid date: **April 23, 2018**  
Time: **2:00 p.m.**  
Location: **USC Procurement, 1300 Pickens Street, Columbia , SC 29208,-  
Conference Room 100C.**
  - 2) Construction Days: **78** days.
- d. Review unique conditions and constraints of the project, site, and specifications:
  - 1) Parking / Loading. (Tight Area; Shared) Limited Parking on Site. Contractor to coordinate with Owner.
  - 2) This is an operating campus, occupied building and site; "Classroom" facilities.
    - a) Construction paths to be defined by USC-Aiken representative, Brian Enter (from Exterior).
    - b) Classrooms will not be occupied, but several summer camps and others will be onsite for use of the Science Center. Loud activities to be coordinated with USC-Aiken representative.
    - c) Dust protection provisions apply to the work.
  - 3) Conduct on Site:
    - a) Proper Behaviour & Attire is required.
  - 5) See Alternates for:
    - a) **ALTERNATE NO. 1:** (2<sup>ND</sup> Level) Construct sound attenuated partitions; prime and paint GPDW walls & door frames. Install new drop ceiling, lights fixtures, HVAC grilles & AV infrastructure. Prime and paint CMU walls.



**PRE-BID CONFERENCE AGENDA  
RUTH PATRICK CLASSROOM RENOVATIONS  
UNIVERSITY OF SOUTH CAROLINA - AIKEN  
AIKEN, SOUTH CAROLINA  
PROJECT NUMBER 2KM#: 2017-17**

**Date:** *April 10, 2018*

**Location:** *Pickens-Salley House, Conference Room*

**Time:** *10:00 A.m.*

*471 University Parkway  
Aiken, SC 29801*

- 4. Addendum #1:**
  - a. Clarifications.
  - b. Pre-bid Agenda and sign-in sheet.
  - c. Pre-Qualified Bidders per qualifications package submittal.
  
- 5. Open for questions.**
  
- 7. Site tour.**
  
- 8. Adjourn meeting.**

**University of South Carolina  
Pre Bid Sign In Sheet  
Columbia, South Carolina**

Project Name: Ruth Patrick Classroom  
 Modifications  
 Project Number: 50003278  
 Pre Bid Date & Time: April 10, 2018@10:00am  
 Sally Pickens Conference Room

SWMBE Contractor?	Name	Company Name	Address	Phone #	Email
S W M B E	Eric Bowen	JH Cleveland	614 Gibbs Rd.	706-833-4886	eric@jhcleveland.com
S W M B E	Cheris Yost	Larry Pittman's Assoc.	1241 Gordon Park Rd	706-724-7602	twilliams@LPA-GA.com
S W M B E	Allen Kinsey	FIRST CLASS CONST	Subec Rd/Columbia	803 626 9921	AKINSEY@ECON.COM
S W M B E	CHRIS LEHI	ZKM ARCHITECTS, INC.	529 GREEN ST AVE	706-736-3333	CLLEHI@ZKMARCHITECTS.COM
S W M B E	Rob Mauldin	ZKM Architects, Inc.	529 Greene St. Ave. GA	706-736-3333	rmauldin@zkmarchitects.com
S W M B E	George Raborn	Stewart Builders	248 Aiken S.C.	803 648 4605	geo@stewartbuilders.com
S W M B E	Rick Campbell	MDC	89 MILL AVE COLUMBIA, SC 29290	803 840 4488	BUDS@MDILLONCONSTRUCTION.COM
* S W M B E	Thatcher Hurt	USC	1300 Pickens St.	576 5840	hurtth@mailbox.sc.edu
* S W M B E	Hatice Hikmet	USC	1300 Pickens St	777-9994	hikmeth@mailbox.sc.edu
S W M B E					
S W M B E					
S W M B E					
S W M B E					
S W M B E					
S W M B E					
S W M B E					

\*\*\*By signing this sheet you agree to receive information electronically.

\* via teleconference

✓



## PROJECT MEETING REPORT

<b>Project Name:</b>	USC-Aiken Ruth Patrick Classroom Modifications	<b>Project No.:</b>	50003278 2KM #17-17
<b>Meeting Location:</b>	Project Site (USC-Aiken Campus)	<b>Date:</b>	04/10/2018
<b>Purpose:</b>	Pre-Bid Conference & Walk Through	<b>Time:</b>	10:00 AM

### ATTENDEES

NAME	FIRM	EMAIL
See Attached Sign -in Sheet		

ITEM	DESCRIPTION	ACTION	BY
I.	<p>Discussion:</p> <p>A. H. Hikmet with USC Procurement began meeting by reviewing key points for the bid submittal:</p> <ol style="list-style-type: none"> <li>1. Project can begin soon after award and will have a 78-day duration, with a target start date May 14<sup>th</sup> and completion prior to the Fall Semester.</li> <li>2. Project budget range is \$90,000 to \$100,000</li> <li>3. Bid bond, payment and performance bonds are required for this project. 5% x Base bid for bid bond Current forms are to be used and can be downloaded from the procurement website</li> <li>4. Bids close on August 23, 2018 @ 10:00 AM. If mailed, bids are to be sent to the Columbia address provided in the Project Manual.</li> <li>5. Date of the RFI's and clarifications for last addendum posting will be <u>April 18, 2018</u>. Deadline for questions on the construction documents must be submitted in writing to 2KM Architects by <u>April 16, 2018 @ 5:00 PM</u>.</li> <li>6. H. Hikmet reminded the perspective contractors to continue to check the web site for addenda.</li> <li>7. An addendum will be issued immediately that will include the meeting minutes, sign-in sheet and any clarifications or updates prepared.</li> </ol> <p>B. C. Lehi and R. Mauldin gave a brief description of project and known expectations:</p> <ol style="list-style-type: none"> <li>1. Project Base Bid is being completed to install a sound attenuation wall &amp; door that will create two separate classrooms; to replace the ceiling tile and paint in the administration offices and to update the light fixtures to LED's.</li> <li>2. C. Lehi reviewed the scope of work as listed on the Construction Documents.</li> <li>3. One (1) Add Alternate has been designed for building out the second-floor classrooms and is listed within the Construction Documents.</li> </ol>		

	<p>4. Entry and egress is required to be maintained, clean-up to be continuous. Classes will not be in session in other parts of the building however, multiple summer camps will be underway throughout the building.</p> <p>5. Entry, parking and lay down yard may be arranged near the rear of the build to have a construction entrance directly to the site.</p> <p>6. Seismic zone for acoustical ceiling grid is Zone "B".</p> <p>7. USC-Aiken will remove all items from site.</p> <p>C. C. Lehi introduced B. Enter as the main USC-A Point Of Contact for the project and will be handling campus coordination and day to day interactions with the contractors.</p> <p>1. Additional site visits are allowed, 24 hours' notice to be given to B. Enter. His contact information is <a href="mailto:BrianEn@usca.edu">BrianEn@usca.edu</a>, 803-641-3254.</p> <p>2. There are no anticipated work hour restrictions and building use will be coordinated through B. Enter. Planetarium shows are on Saturdays. Work access is 7 days/week.</p> <p>3. Water &amp; electricity will be provided. Port-o-lets to be provided by contractor, all workers are to have an identifying shirt or vest &amp; legal photo I.D.</p>		
II.	<p>Site Review:</p> <p>A. Group began site walk-through. Items emphasized included:</p> <ol style="list-style-type: none"> <li>1. Relocate thermostat on the steel tube column to GPDW Wall.</li> <li>2. Finish notes were left off plan of Room 104 but are to be priced and will be included in Addendum.</li> <li>3. Replace lamps to LED and replace select fixtures.</li> <li>4. AV equipment is to be protected by dust control measures.</li> <li>5. Painting will not be required on the CMU walls; all new GPDW walls are to be primes and painted. (Issue addendum)</li> <li>6. Backside of the 2nd floor sound attenuated wall facing the first floor is not required to be painted. (Add Alternate)</li> </ol>		
III.	Meeting Adjourned		

Please notify the recorder of these minutes of corrections within 10 days of receipt.

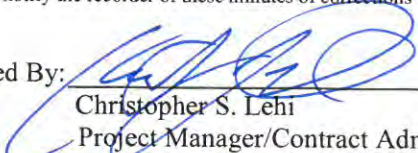
Submitted By:   
 Christopher S. Lehi  
 Project Manager/Contract Administrator

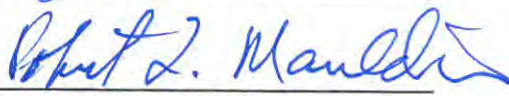
Approved By:   
 Robert L. Mauldin, NCARB, AIA  
 Principal Architect, GA-RA-005958

This document is property of 2KM Architects, Inc. The unauthorized reproduction, copying, or otherwise use of this document is strictly prohibited and any infringement thereupon may be subject to legal action. Copyright © 2018, 2KM Architects, Inc.

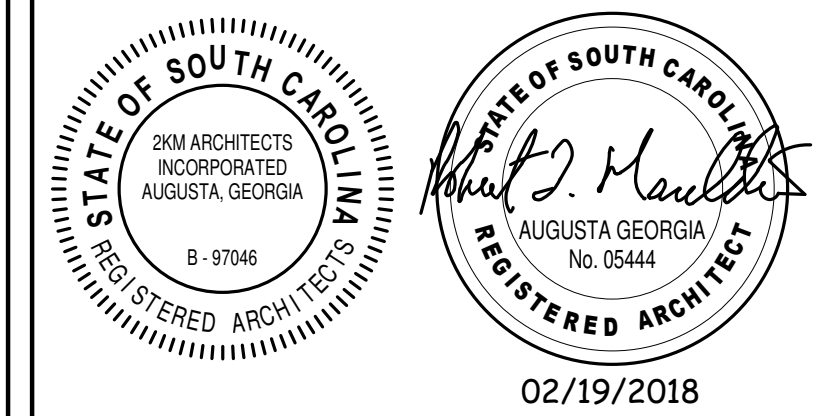

**ADD ALTERNATE #1:**  
INSTALLED WORK ASSOCIATED WITH LEVEL 2 CLASSROOMS

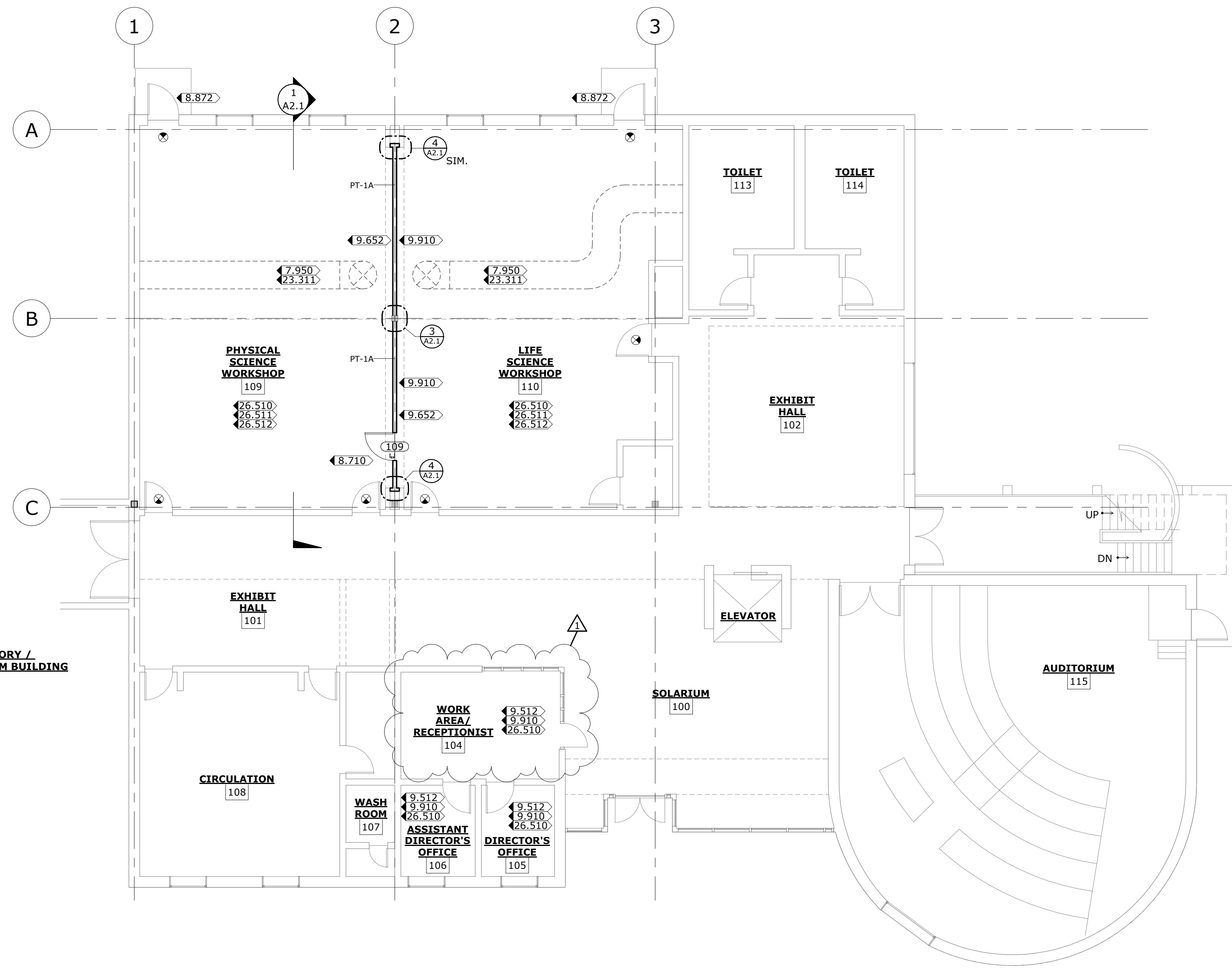

**1 FIRST FLOOR PLAN - NEW WORK PLAN**  
SCALE: 1/8" = 1'-0"

**NOTE:**  
EXISTING VCT TO REMAIN

**DOOR AND FRAME TYPES**

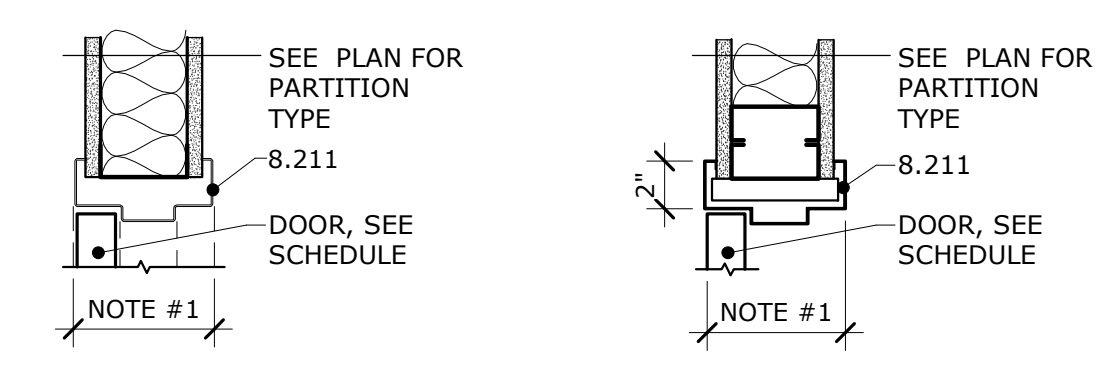

**1 HEAD DETAIL**      **2 JAMB DETAIL**

- NOTES:**
- 6" FRAME FOR 3 5/8" LGMF.  
8 1/2" FRAME FOR 6" LGMF.  
SEE PARTITION TYPES FOR SIZE.
  - ADD TO FRAME SIZE WHERE MULTIPLE LAYERS OF GPDW ARE INDICATED ON PARTITION TYPES.

**DOOR AND FRAME TYPES**

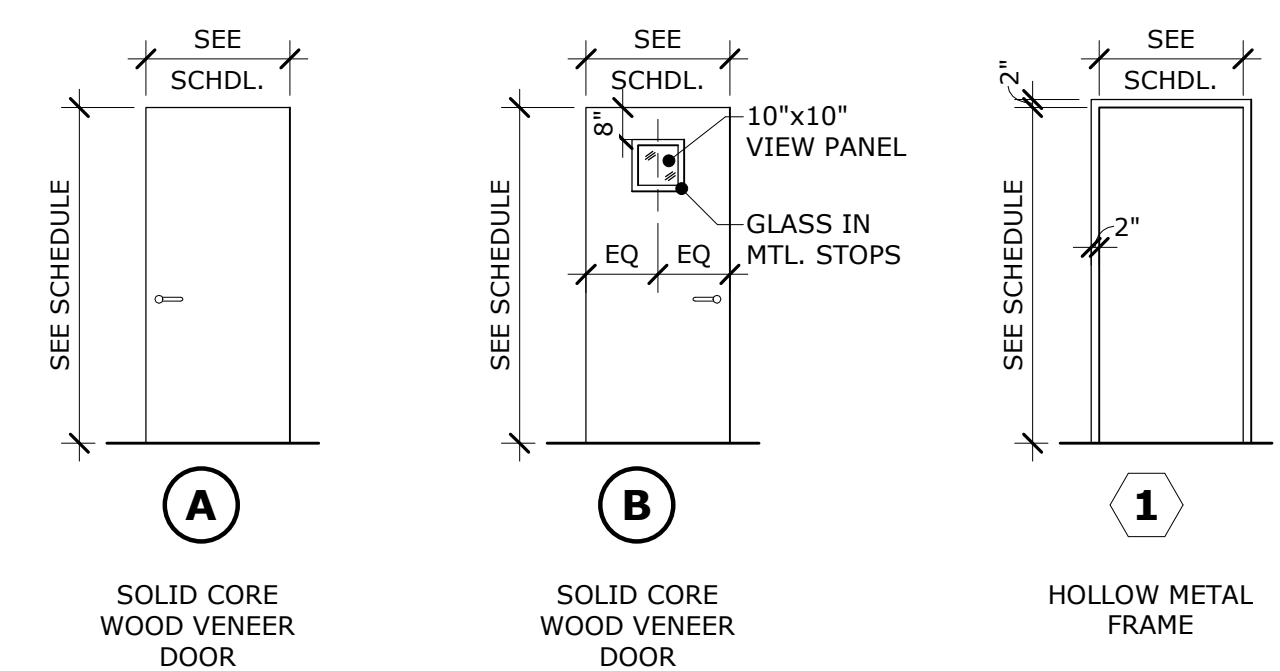

**DOOR SCHEDULE**

DOOR NO.	DOOR					GLASS		FRAME		FRAME DETAILS			LABEL	SET	REMARKS
	WIDTH	HEIGHT	THICK	TYPE	FINISH	SIZE	G. TYPE	F. TYPE	MATERIAL	HEAD	JAMB	SILL			
109	3'-0"	7'-0"	1 3/4"	B	STAIN	10x10	TEMP.	1	H.M.	1	2	-	-	1	
201A	3'-0"	7'-0"	1 3/4"	A	STAIN	-	-	1	H.M.	1	2	-	-	2	ADD ALT. #1
201B	3'-0"	7'-0"	1 3/4"	A	STAIN	-	-	1	H.M.	1	2	-	-	2	ADD ALT. #1

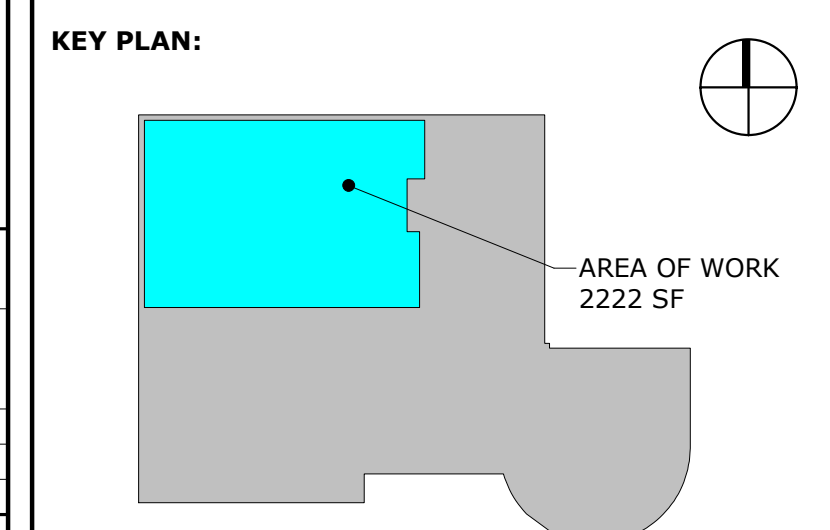

**REVISIONS:**

Date	Description
4-18-2018	ADDENDUM #1

**PROJECT 50003278**  
**USC-AIKEN RUTH PATRICK CLASSROOM RENOVATIONS**  
FOR  
**USC AIKEN**  
471 UNIVERSITY PKWY, AIKEN, SC 29801

**DRAWING TITLE**  
**FIRST FLOOR PLAN - NEW WORK PLAN**

PROJECT NO.	17-17	DRAWING NO.	
DATE	02-19-2018		
DRAWN BY	RS		
PAPER	24"x36"		<b>A1.1</b>
ISSUE	CD		

**PARTITION TYPES**

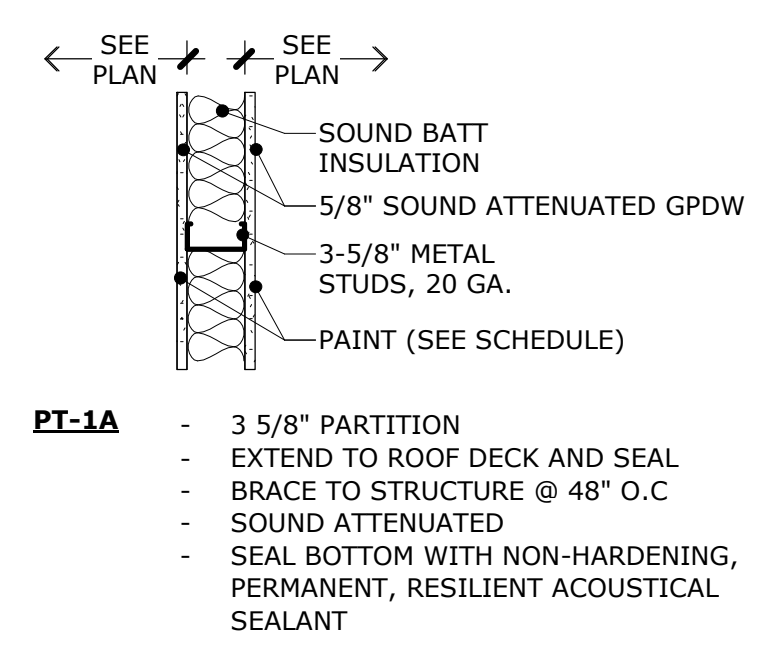

**FINISH SCHEDULE - LEVEL 1**

ROOM NO.	SPACE	FLOOR	BASE	WALLS	CEILING	CLG. HT.	NOTES
109	PHYSICAL SCIENCE WORKSHOP	-	A	1	-	-	EXIS. NEW WALL TO MATCH EXISTING
110	LIFE SCIENCE WORKSHOP	-	A	1	-	-	EXIS. NEW WALL TO MATCH EXISTING

**MATERIAL SCHEDULE**

FLOOR		WALLS	
	1	1	PRIME & PAINT (EGGSHELL), 2 FINISH COATS
	2	2	PRIME & PAINT (SEMI-GLOSS), 2 FINISH COATS
BASE		CEILINGS	
A	4" RUBBER	A	SOUND ACOUSTICAL TILE CEILING

**CONSTRUCTION NOTES**

- DIVISION 7 - THERMAL & MOISTURE PROTECTION**  
 ◀7.950> ACOUSTICAL SEAL AROUND SUPPLY & RETURN DUCTS.
- DIVISION 8 - DOORS & WINDOWS**  
 ▶8.710> INSTALL NEW DOOR & FRAME AND LEVER HARDWARE.  
 ▶8.872> INSTALL NEW REFLECTIVE SOLAR FILM ON DOOR GLASS.
- DIVISION 9 - FINISHES**  
 ▶9.512> REPLACE EXISTING ATC TILE WITH NEW ATC TILE.  
 ▶9.652> INSTALL NEW 4" COVERED RUBBER BASE ON NEW WALLS. (MATCH EXISTING COLOR)  
 ▶9.910> PRIME AND PAINT GPDW, DOOR FRAMES, & TRIM. CLEAN ALL PAINT SURFACES W/ SYNTHETIC TSP SOLUTION FOR NEW PAINT SURFACE PREPARATION.
- DIVISION 23 - HVAC**  
 ▶23.311> REWORK DUCTS ON SUPPLY IN ROOM #109.
- DIVISION 26 - ELECTRICAL**  
 ▶26.510> RELAMP OR REPLACE FIXTURES FOR LED PER ELECTRICAL PLANS.  
 ▶26.511> ADD NOTIFICATION DEVICES IN SPACE.  
 ▶26.512> ADD EGRESS LIGHTING ABOVE DOOR.

Z:\Active\_Projects\2017 Projects\17 USC Aiken Ruth Pat Classroom\DRAWINGS\CD Construction Documents\W1.PWD\DEL.rvt  
PRINTED: 4/16/2018 4:39:05 PM



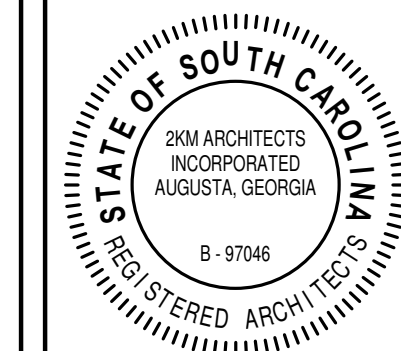

02/19/2018

**ADD ALTERNATE #1:**  
INSTALLED WORK ASSOCIATED WITH LEVEL 2 CLASSROOMS

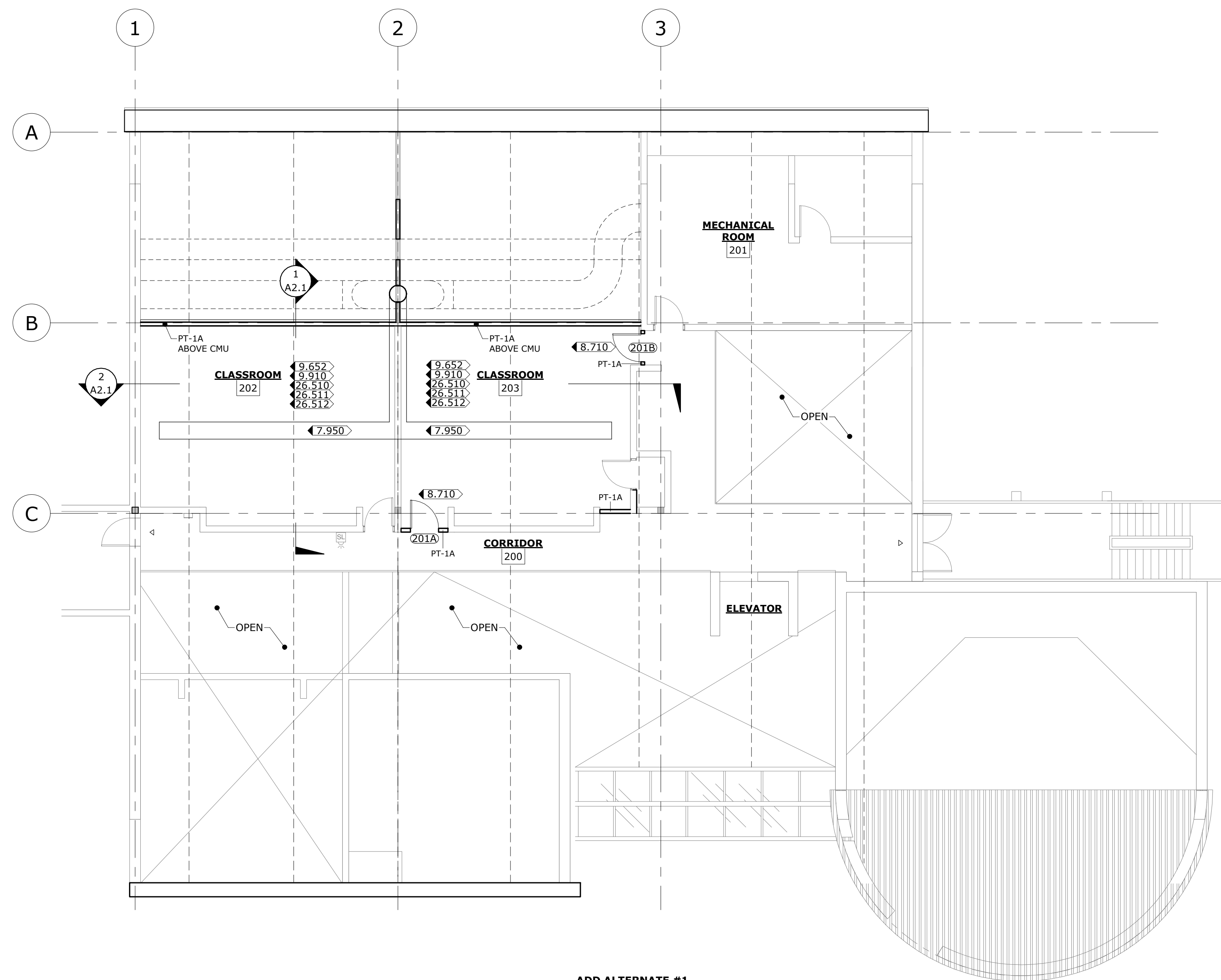

**1 SECOND FLOOR PLAN - ADD ATL. #1**  
A2.1 SCALE: 1/8" = 1'-0"

KEY PLAN:

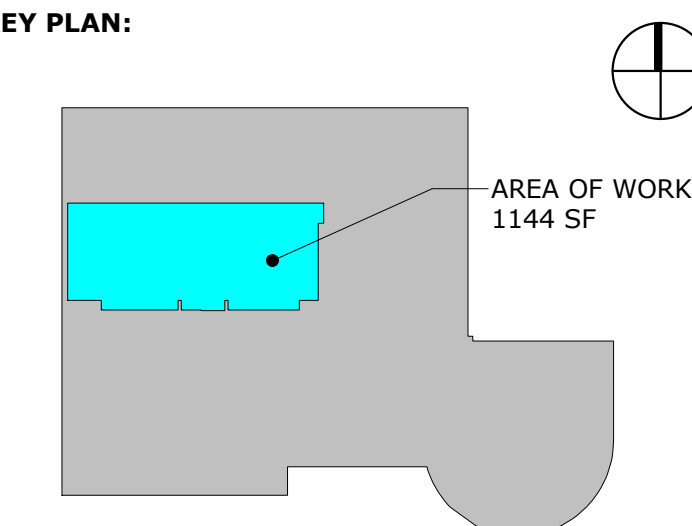

REVISIONS:

Date	Description
4-18-2018	ADDENDUM #1

**PROJECT 50003278**

**USC-AIKEN RUTH PATRICK CLASSROOM RENOVATIONS**

FOR

**USC AIKEN**

471 UNIVERSITY PKWY, AIKEN, SC 29801

DRAWING TITLE

**SECOND FLOOR PLAN - ADD ALTERNATE #1**

PROJECT NO.	17-17	DRAWING NO.	<b>A1.2</b>
DATE	02-19-2018		
DRAWN BY	RS		
PAPER	24"x36"		
ISSUE	CD		

**FINISH SCHEDULE - LEVEL 2**

ROOM NO.	SPACE	FLOOR	BASE	WALLS	CEILING	CLG. HT.	NOTES
202	CLASSROOM	-	A	1	A	9'-4"	
203	CLASSROOM	-	A	1	A	9'-4"	

**MATERIAL SCHEDULE**

FLOOR		WALLS	
		1	PRIME & PAINT (EGGSHELL), 2 FINISH COATS
		2	PRIME & PAINT (SEMI-GLOSS), 2 FINISH COATS
BASE		CEILING	
A	4" RUBBER	A	SOUND ACCOUSTICAL TILE CEILING

**CONSTRUCTION NOTES**

**DIVISION 7 - THERMAL & MOISTURE PROTECTION**

7.950 ACCOUSTICAL SEAL AROUND SUPPLY & RETURN DUCTS.

**DIVISION 8 - DOORS & WINDOWS**

8.710 INSTALL NEW DOOR & FRAME AND LEVER HARDWARE.  
8.872 INSTALL NEW REFLECTIVE SOLAR FILM ON DOOR GLASS.

**DIVISION 9 - FINISHES**

9.512 REPLACE EXISTING ATC TILE WITH NEW ATC TILE.  
9.652 INSTALL NEW 4" COVERED RUBBER BASE ON NEW WALLS. (MATCH EXISTING COLOR)  
9.910 PRIME AND PAINT GPDW, DOOR FRAMES, & TRIM. CLEAN ALL PAINT SURFACES W/ SYNTHETIC TSP SOLUTION FOR NEW PAINT SURFACE PREPARATION.

**DIVISION 23 - HVAC**

23.311 REWORK DUCTS ON SUPPLY IN ROOM #109.

**DIVISION 26 - ELECTRICAL**

26.510 RELAMP OR REPLACE FIXTURES FOR LED PER ELECTRICAL PLANS.  
26.511 ADD NOTIFICATION DEVICES IN SPACE.  
26.512 ADD EGRESS LIGHTING ABOVE DOOR.