

 UNIVERSITY OF SOUTH CAROLINA	Invitation for Bid	Solicitation Number: USC-IFB-3171-JB Date Issued: July 12, 2017 Procurement Officer: Juaquana Brookins Phone: 803.777.3596 E-Mail Address: jbrookin@fmc.sc.edu
--	---------------------------	---

DESCRIPTION: **Provide Elevated Running Support Structure**

USING GOVERNMENTAL UNIT: **University of South Carolina**

The Term "Offer" Means Your "Bid" or "Proposal". Your offer must be submitted in a sealed package. Solicitation Number & Opening Date must appear on package exterior. See "Submitting Your Paper Offer or Modification" provision.

SUBMIT YOUR SEALED OFFER TO EITHER OF THE FOLLOWING ADDRESSES:

MAILING ADDRESS: University of South Carolina 1600 Hampton Street, Suite 606 Columbia SC 29208	PHYSICAL ADDRESS: University of South Carolina 1600 Hampton Street, Suite 606 Columbia SC 29208
--	---

SUBMIT OFFER BY (Opening Date/Time): **July 26, 2017 2:00 PM EST** (See "Deadline For Submission Of Offer" provision)

QUESTIONS MUST BE RECEIVED BY: **July 18, 2017 10:00 AM EST** via email to jbrookin@fmc.sc.edu (See "Questions From Offerors" provision)

NUMBER OF COPIES TO BE SUBMITTED: **One(1) paper copy and one (1) USB drive**

CONFERENCE TYPE: NA DATE & TIME: (As appropriate, see "Conferences - Pre-Bid/Proposal" & "Site Visit" provisions)	LOCATION: NA
---	---------------------

AWARD & AMENDMENTS	Award will be posted on 07/28/2017 . The award, this solicitation, any amendments, and any related notices will be posted at the following web address: http://www.purchasing.sc.edu
-----------------------------------	--

You must submit a signed copy of this form with Your Offer. By signing, You agree to be bound by the terms of the Solicitation. You agree to hold Your Offer open for a minimum of thirty (30) calendar days after the Opening Date.
(See "Signing Your Offer" provision.)

NAME OF OFFEROR (full legal name of business submitting the offer)	Any award issued will be issued to, and the contract will be formed with, the entity identified as the Offeror. The entity named as the offeror must be a single and distinct legal entity. Do not use the name of a branch office or a division of a larger entity if the branch or division is not a separate legal entity, i.e., a separate corporation, partnership, sole proprietorship, etc.
AUTHORIZED SIGNATURE (Person must be authorized to submit binding offer to contract on behalf of Offeror.)	DATE SIGNED
TITLE (business title of person signing above)	STATE VENDOR NO.
PRINTED NAME (printed name of person signing above)	STATE OF INCORPORATION (If you are a corporation, identify the state of incorporation.)

OFFEROR'S TYPE OF ENTITY: (Check one)	(See "Signing Your Offer" provision.)
<input type="checkbox"/> Sole Proprietorship	<input type="checkbox"/> Partnership
<input type="checkbox"/> Corporate entity (not tax-exempt)	<input type="checkbox"/> Corporation (tax-exempt)
<input type="checkbox"/> Other _____	<input type="checkbox"/> Government entity (federal, state, or local)

PAGE TWO
(Return Page Two with Your Offer)

<p>HOME OFFICE ADDRESS (Address for offeror's home office / principal place of business)</p> 	<p>NOTICE ADDRESS (Address to which all procurement and contract related notices should be sent.) (See "Notice" clause)</p> <p>Area Code - Number - Extension Facsimile</p> <p>_____ E-mail Address</p>
--	---

<p>PAYMENT ADDRESS (Address to which payments will be sent.) (See "Payment" clause)</p> <p>____ Payment Address same as Home Office Address ____ Payment Address same as Notice Address (check only one)</p>	<p>ORDER ADDRESS (Address to which purchase orders will be sent) (See "Purchase Orders and "Contract Documents" clauses)</p> <p>____ Order Address same as Home Office Address ____ Order Address same as Notice Address (check only one)</p>
--	---

ACKNOWLEDGMENT OF AMENDMENTS
 Offerors acknowledges receipt of amendments by indicating amendment number and its date of issue. (See "Amendments to Solicitation" Provision)

Amendment No.	Amendment Issue Date	Amendment No.	Amendment Issue Date	Amendment No.	Amendment Issue Date	Amendment No.	Amendment Issue Date

<p>DISCOUNT FOR PROMPT PAYMENT (See "Discount for Prompt Payment" clause)</p>	<p>10 Calendar Days (%)</p>	<p>20 Calendar Days (%)</p>	<p>30 Calendar Days (%)</p>	<p>____ Calendar Days (%)</p>
--	-----------------------------	-----------------------------	-----------------------------	-------------------------------

PREFERENCES - A NOTICE TO VENDORS (SEP. 2009): On June 16, 2009, the South Carolina General Assembly rewrote the law governing preferences available to in-state vendors, vendors using in-state subcontractors, and vendors selling in-state or US end products. This law appears in Section 11-35-1524 of the South Carolina Code of Laws. A summary of the new preferences is available at www.procurement.sc.gov/preferences. **ALL THE PREFERENCES MUST BE CLAIMED AND ARE APPLIED BY LINE ITEM, REGARDLESS OF WHETHER AWARD IS MADE BY ITEM OR LOT. VENDORS ARE CAUTIONED TO CAREFULLY REVIEW THE STATUTE BEFORE CLAIMING ANY PREFERENCES. THE REQUIREMENTS TO QUALIFY HAVE CHANGED. IF YOU REQUEST A PREFERENCE, YOU ARE CERTIFYING THAT YOUR OFFER QUALIFIES FOR THE PREFERENCE YOU'VE CLAIMED. IMPROPERLY REQUESTING A PREFERENCE CAN HAVE SERIOUS CONSEQUENCES. [11-35-1524(E)(4)&(6)] PREFERENCES DO NOT APPLY**

PREFERENCES - ADDRESS AND PHONE OF IN-STATE OFFICE: Please provide the address and phone number for your in-state office in the space provided below. An in-state office is necessary to claim either the Resident Vendor Preference (11-35-1524(C)(1)(i)&(ii)) or the Resident Contractor Preference (11-35-1524(C)(1)(iii)). Accordingly, you must provide this information to qualify for the preference. An in-state office is not required, but can be beneficial, if you are claiming the Resident Subcontractor Preference (11-35-1524(D)). **PREFERENCES DO NOT APPLY**

____ In-State Office Address same as Home Office Address
 ____ In-State Office Address same as Notice Address (check only one)

Solicitation Outline

- I. Scope of Solicitation
- II. Instructions to Offerors
 - A. General Instructions
 - B. Special Instructions
- III. Scope of Work / Specifications
May be blank if Bidding Schedule / Cost Proposal attached
- IV. Information for Offerors to Submit
- V. Qualifications
- VI. Award Criteria
- VII. Terms and Conditions
 - A. General
 - B. Special
- VIII. Bidding Schedule / Cost Proposal
- IX. Attachments to Solicitation

I. SCOPE OF SOLICITATION

University of South Carolina is soliciting bids from qualified sources to furnish and install an elevated running support structure as described herein.

ACQUIRE SERVICES & SUPPLIES / EQUIPMENT (JAN 2006)

The purpose of this solicitation is to acquire services and supplies or equipment complying with the enclosed description and/or specifications and conditions.

MAXIMUM CONTRACT PERIOD -- ESTIMATED

Start date: **8/8/2017** End date: **12/30/2017**. Dates provided are estimates only. Any resulting contract will begin on the date specified in the notice of award. See clause entitled "Term of Contract - Effective Date/Initial Contract Period.

II. INSTRUCTIONS TO OFFERORS - A. GENERAL INSTRUCTIONS

DEFINITIONS, CAPITALIZATION, AND HEADINGS (FEB 2015)

CLAUSE HEADINGS USED IN THIS SOLICITATION ARE FOR CONVENIENCE ONLY AND SHALL NOT BE USED TO CONSTRUE MEANING OR INTENT. EVEN IF NOT CAPITALIZED, THE FOLLOWING DEFINITIONS ARE APPLICABLE TO ALL PARTS OF THE SOLICITATION, UNLESS EXPRESSLY PROVIDED OTHERWISE.

AMENDMENT means a document issued to supplement the original solicitation document.

BOARD means the South Carolina Budget & Control Board or its successor in interest.

BUSINESS means any corporation, partnership, individual, sole proprietorship, joint stock company, joint venture, or any other legal entity. [11-35-310(3)]

CHANGE ORDER means any written alteration in specifications, delivery point, rate of delivery, period of performance, price, quantity, or other provisions of any contract accomplished by mutual agreement of the parties to the contract. [11-35-310(4)]

CONTRACT See clause entitled Contract Documents & Order of Precedence.

CONTRACT MODIFICATION means a written order signed by the procurement officer, directing the contractor to make changes which the clause of the contract titled "Changes," if included herein, authorizes the Procurement Officer to order without the consent of the contractor. [11-35-310(9)]

CONTRACTOR means the Offeror receiving an award as a result of this solicitation.

COVER PAGE means the top page of the original solicitation on which the solicitation is identified by number. Offerors are cautioned that Amendments may modify information provided on the Cover Page.

OFFER means the bid or proposal submitted in response this solicitation. The terms Bid and Proposal are used interchangeably with the term Offer.

OFFEROR means the single legal entity submitting the offer. The term Bidder is used interchangeably with the term Offeror. See bidding provisions entitled Signing Your Offer and Bid/Proposal As Offer To Contract.

PAGE TWO means the second page of the original solicitation, which is labeled Page Two.

PROCUREMENT OFFICER means the person, or his successor, identified as such on either the Cover Page, an amendment, or an award notice.

YOU and **YOUR** means Offeror.

SOLICITATION means this document, including all its parts, attachments, and any Amendments.

STATE means the Using Governmental Unit(s) identified on the Cover Page.

SUBCONTRACTOR means any person you contract with to perform or provide any part of the work.
US or WE means the using governmental unit.

USING GOVERNMENTAL UNIT means the unit(s) of government identified as such on the Cover Page. If the Cover Page identifies the Using Governmental Unit as "Statewide Term Contract," the phrase "Using Governmental Unit" means any South Carolina Public Procurement Unit [11-35-4610(5)] that has submitted a Purchase Order to you pursuant to the contract resulting from this solicitation. Reference the clauses titled "Purchase Orders" and "Statewide Term Contract."

WORK means all labor, materials, equipment, services, or property of any type, provided or to be provided by the Contractor to fulfill the Contractor's obligations under the Contract.

AMENDMENTS TO SOLICITATION

(a) The Solicitation may be amended at any time prior to opening. All actual and prospective Offerors should monitor the following web site for the issuance of Amendments: <http://purchasing.sc.edu>. (b) Offerors shall acknowledge receipt of any amendment to this solicitation (1) by signing and returning the amendment, (2) by identifying the amendment number and date in the space provided for this purpose on Page Two, (3) by letter, or (4) by submitting a bid that indicates in some way that the bidder received the amendment. (c) If this solicitation is amended, then all terms and conditions which are not modified remain unchanged.

AUTHORIZED AGENT (FEB 2015)

All authority regarding this procurement is vested solely with the responsible Procurement Officer. Unless specifically delegated in writing, the Procurement Officer is the only government official authorized to bind the government with regard to this procurement or the resulting contract.

AWARD NOTIFICATION (FEB 2015)

Notice regarding any award, cancellation of award, or extension of award will be posted at the location and on the date specified on the Cover Page or, if applicable, any notice of extension of award. Should the contract resulting from this Solicitation have a total or potential value of one hundred thousand dollars or more, such notice will be sent to all Offerors responding to the Solicitation and any award will not be effective until the eleventh day after such notice is given.

BID / PROPOSAL AS OFFER TO CONTRACT (JAN 2004)

By submitting Your Bid or Proposal, You are offering to enter into a contract with the Using Governmental Unit(s). Without further action by either party, a binding contract shall result upon final award. Any award issued will be issued to, and the contract will be formed with, the entity identified as the Offeror on the Cover Page. An Offer may be submitted by only one legal entity; "joint bids" are not allowed.

BID ACCEPTANCE PERIOD (JAN 2004)

In order to withdraw Your Offer after the minimum period specified on the Cover Page, You must notify the Procurement Officer in writing.

BID IN ENGLISH & DOLLARS (JAN 2004)

Offers submitted in response to this solicitation shall be in the English language and in US dollars, unless otherwise permitted by the Solicitation.

CERTIFICATE OF INDEPENDENT PRICE DETERMINATION (MAY 2008)

GIVING FALSE, MISLEADING, OR INCOMPLETE INFORMATION ON THIS CERTIFICATION MAY RENDER YOU SUBJECT TO PROSECUTION UNDER SECTION 16-9-10 OF THE SOUTH CAROLINA CODE OF LAWS AND OTHER APPLICABLE LAWS.

(a) By submitting an offer, the offeror certifies that-

(1) The prices in this offer have been arrived at independently, without, for the purpose of restricting competition, any consultation, communication, or agreement with any other offeror or competitor relating to—

(i) Those prices;

(ii) The intention to submit an offer; or

(iii) The methods or factors used to calculate the prices offered.

(2) The prices in this offer have not been and will not be knowingly disclosed by the offeror, directly or indirectly, to any other offeror or competitor before bid opening (in the case of a sealed bid solicitation) or contract award (in the case of a negotiated solicitation) unless otherwise required by law; and

(3) No attempt has been made or will be made by the offeror to induce any other concern to submit or not to submit an offer for the purpose of restricting competition.

(b) Each signature on the offer is considered to be a certification by the signatory that the signatory-

- (1) Is the person in the offeror's organization responsible for determining the prices being offered in this bid or proposal, and that the signatory has not participated and will not participate in any action contrary to paragraphs (a)(1) through (a)(3) of this certification; or
- (2)(i) Has been authorized, in writing, to act as agent for the offeror's principals in certifying that those principals have not participated, and will not participate in any action contrary to paragraphs (a)(1) through (a)(3) of this certification [As used in this subdivision (b)(2)(i), the term "principals" means the person(s) in the offeror's organization responsible for determining the prices offered in this bid or proposal];
- (ii) As an authorized agent, does certify that the principals referenced in subdivision (b)(2)(i) of this certification have not participated, and will not participate, in any action contrary to paragraphs (a)(1) through (a)(3) of this certification; and
- (iii) As an agent, has not personally participated, and will not participate, in any action contrary to paragraphs (a)(1) through (a)(3) of this certification.
- (c) If the offeror deletes or modifies paragraph (a)(2) of this certification, the offeror must furnish with its offer a signed statement setting forth in detail the circumstances of the disclosure.

CERTIFICATION REGARDING DEBARMENT AND OTHER RESPONSIBILITY MATTERS (JAN 2004)

- (a) (1) By submitting an Offer, Offeror certifies, to the best of its knowledge and belief, that-
- (i) Offeror and/or any of its Principals-
- (A) Are not presently debarred, suspended, proposed for debarment, or declared ineligible for the award of contracts by any state or federal agency;
- (B) Have not, within a three-year period preceding this offer, been convicted of or had a civil judgment rendered against them for: commission of fraud or a criminal offense in connection with obtaining, attempting to obtain, or performing a public (Federal, state, or local) contract or subcontract; violation of Federal or state antitrust statutes relating to the submission of offers; or commission of embezzlement, theft, forgery, bribery, falsification or destruction of records, making false statements, tax evasion, or receiving stolen property; and
- (C) Are not presently indicted for, or otherwise criminally or civilly charged by a governmental entity with, commission of any of the offenses enumerated in paragraph (a)(1)(i)(B) of this provision.
- (ii) Offeror has not, within a three-year period preceding this offer, had one or more contracts terminated for default by any public (Federal, state, or local) entity.
- (2) "Principals," for the purposes of this certification, means officers; directors; owners; partners; and, persons having primary management or supervisory responsibilities within a business entity (e.g., general manager; plant manager; head of a subsidiary, division, or business segment, and similar positions).
- (b) Offeror shall provide immediate written notice to the Procurement Officer if, at any time prior to contract award, Offeror learns that its certification was erroneous when submitted or has become erroneous by reason of changed circumstances.
- (c) If Offeror is unable to certify the representations stated in paragraphs (a)(1), Offer must submit a written explanation regarding its inability to make the certification. The certification will be considered in connection with a review of the Offeror's responsibility. Failure of the Offeror to furnish additional information as requested by the Procurement Officer may render the Offeror nonresponsible.
- (d) Nothing contained in the foregoing shall be construed to require establishment of a system of records in order to render, in good faith, the certification required by paragraph (a) of this provision. The knowledge and information of an Offeror is not required to exceed that which is normally possessed by a prudent person in the ordinary course of business dealings.
- (e) The certification in paragraph (a) of this provision is a material representation of fact upon which reliance was placed when making award. If it is later determined that the Offeror knowingly or in bad faith rendered an erroneous certification, in addition to other remedies available to the State, the Procurement Officer may terminate the contract resulting from this solicitation for default.

CODE OF LAWS AVAILABLE (JAN 2006)

The South Carolina Code of Laws, including the Consolidated Procurement Code, is available at <http://www.scstatehouse.gov/code/statmast.php>. The South Carolina Regulations are available at: <http://www.scstatehouse.gov/coderegs/statmast.php>.

DISCLOSURE OF CONFLICTS OF INTEREST OR UNFAIR COMPETITIVE ADVANTAGE (FEB 2015)

You warrant and represent that your offer identifies and explains any unfair competitive advantage you may have in competing for the proposed contract and any actual or potential conflicts of interest that may arise from your participation in this competition or your receipt of an award. The two underlying principles are (a) preventing the existence of conflicting roles that might bias a contractor's judgment, and (b) preventing an unfair competitive advantage. If you have an unfair competitive advantage or a conflict of interest, the state may withhold award.

Before withholding award on these grounds, an offeror will be notified of the concerns and provided a reasonable opportunity to respond. Efforts to avoid or mitigate such concerns, including restrictions on future activities, may be considered. Without limiting the foregoing, you represent that your offer identifies any services that relate to either this solicitation or the work and that has already been performed by you, a proposed subcontractor, or an affiliated business of either.

DEADLINE FOR SUBMISSION OF OFFER (JAN 2004)

Any offer received after the Procurement Officer of the governmental body or his designee has declared that the time set for opening has arrived, shall be rejected unless the offer has been delivered to the designated purchasing office or the governmental bodies' mail room which services that purchasing office prior to the bid opening. [R.19-445.2070(H)]

DRUG FREE WORK PLACE CERTIFICATION (JAN 2004)

By submitting an Offer, Contractor certifies that, if awarded a contract, Contractor will comply with all applicable provisions of The Drug-free Workplace Act, Title 44, Chapter 107 of the South Carolina Code of Laws, as amended.

DUTY TO INQUIRE (FEB 2015)

Offeror, by submitting an Offer, represents that it has read and understands the Solicitation and that its Offer is made in compliance with the Solicitation. Offerors are expected to examine the Solicitation thoroughly and should request an explanation of any ambiguities, discrepancies, errors, omissions, or conflicting statements in the Solicitation. Failure to do so will be at the Offeror's risk. All ambiguities, discrepancies, errors, omissions, or conflicting statements in the Solicitation shall be interpreted to require the better quality or greater quantity of work and/or materials, unless otherwise directed by amendment. Offeror assumes responsibility for any patent ambiguity in the Solicitation that Offeror does not bring to the State's attention. See clause entitled "Questions from Offerors."

ETHICS CERTIFICATE (MAY 2008)

By submitting an offer, the offeror certifies that the offeror has and will comply with, and has not, and will not, induce a person to violate Title 8, Chapter 13 of the South Carolina Code of Laws, as amended (ethics act). The following statutes require special attention: Section 8-13-700, regarding use of official position for financial gain; Section 8-13-705, regarding gifts to influence action of public official; Section 8-13-720, regarding offering money for advice or assistance of public official; Sections 8-13-755 and 8-13-760, regarding restrictions on employment by former public official; Section 8-13-775, prohibiting public official with economic interests from acting on contracts; Section 8-13-790, regarding recovery of kickbacks; Section 8-13-1150, regarding statements to be filed by consultants; and Section 8-13-1342, regarding restrictions on contributions by contractor to candidate who participated in awarding of contract. The state may rescind any contract and recover all amounts expended as a result of any action taken in violation of this provision. If contractor participates, directly or indirectly, in the evaluation or award of public contracts, including without limitation, change orders or task orders regarding a public contract, contractor shall, if required by law to file such a statement, provide the statement required by Section 8-13-1150 to the procurement officer at the same time the law requires the statement to be filed.

IRAN DIVESTMENT ACT - CERTIFICATION (JAN 2015)

(a) The Iran Divestment Act List is a list published by the Board pursuant to Section 11-57-310 that identifies persons engaged in investment activities in Iran. Currently, the list is available at the following URL: <http://procurement.sc.gov/PS/PS-iran-divestment.phtml> (.). Section 11-57-310 requires the government to provide a person ninety days written notice before he is included on the list. The following representation, which is required by Section 11-57-330(A), is a material inducement for the State to award a contract to you. (b) By signing your Offer, you certify that, as of the date you sign, you are not on the then-current version of the Iran Divestment Act List. (c) You must notify the Procurement Officer immediately if, at any time before posting of a final statement of award, you are added to the Iran Divestment Act List.

OMIT TAXES FROM PRICE (JAN 2004)

Do not include any sales or use taxes in Your price that the State may be required to pay.

OPEN TRADE REPRESENTATION (JUN 2015)

By submitting an Offer, Offeror represents that Offeror is not currently engaged in the boycott of a person or an entity based in or doing business with a jurisdiction with whom South Carolina can enjoy open trade, as defined in SC Code Section 11-35-5300.

PROTESTS (JUNE 2006)

Any prospective bidder, offeror, contractor, or subcontractor who is aggrieved in connection with the solicitation of a contract shall protest within fifteen days of the date of issuance of the applicable solicitation document at issue. Any actual bidder, offeror, contractor, or subcontractor who is aggrieved in connection with the intended award or award of a contract shall protest within ten days of the date notification of award is posted in accordance with this code. A protest shall be in writing, shall set forth the grounds of the protest and the relief requested with enough particularity to give notice of the issues to be decided, and must be received by the appropriate Chief Procurement Officer within the time provided. See clause entitled "Protest-CPO". [Section 11-35-4210]

PROHIBITED COMMUNICATIONS AND DONATIONS (FEB 2015)

Violation of these restrictions may result in disqualification of your offer, suspension or debarment, and may constitute a violation of law.

(a) During the period between publication of the solicitation and final award, ***you must not communicate, directly or indirectly, with the Using Governmental Unit or its employees, agents or officials regarding any aspect of this procurement activity***, unless otherwise approved in writing by the Procurement Officer. All communications must be solely with the Procurement Officer. [R. 19-445.2010]

(b) You are advised to familiarize yourself with Regulation 19-445.2165, which restricts donations to a governmental entity with whom you have or seek to have a contract. ***You represent that your offer discloses any gifts made, directly or through an intermediary, by you or your named subcontractors to or for the benefit of the Using Governmental Unit during the period beginning eighteen months prior to the Opening Date.*** [R. 19-445.2165]

PUBLIC OPENING (JAN 2004)

Offers will be publicly opened at the date / time and at the location identified on the Cover Page, or last Amendment, whichever is applicable.

QUESTIONS FROM OFFERORS (FEB 2015)

Submit Questions via Email only to jbrookin@fmc.sc.edu

Subject: USC-IFB-3171-JB Provide Elevated Running Support Structure

(a) Any prospective offeror desiring an explanation or interpretation of the solicitation, drawings, specifications, etc., must request it in writing. Questions regarding the original solicitation or any amendment must be received by the Procurement Officer no later than five (5) days prior to opening unless an earlier date is stated on the Cover Page. Label any communication regarding your questions with the name of the procurement officer, and the solicitation's title and number. Oral explanations or instructions will not be binding. [See R. 19-445.2042(B)] Any information given a prospective offeror concerning a solicitation will be furnished promptly to all other prospective offerors as an Amendment to the solicitation, if that information is necessary for submitting offers or if the lack of it would be prejudicial to other prospective offerors. See clause entitled "Duty to Inquire." We will not identify you in our answer to your question. (b) The State seeks to permit maximum practicable competition. Offerors are urged to advise the Procurement Officer -- as soon as possible -- regarding any aspect of this procurement, including any aspect of the Solicitation that unnecessarily or inappropriately limits full and open competition. [See R. 19-445.2140]

REJECTION/CANCELLATION (JAN 2004)

The State may cancel this solicitation in whole or in part. The State may reject any or all proposals in whole or in part. [SC Code Section 11-35-1710 & R.19-445.2065.]

RESPONSIVENESS/IMPROPER OFFERS (JUN 2015)

- (a) Bid as Specified. Offers for supplies or services other than those specified will not be considered unless authorized by the Solicitation.
- (b) Multiple Offers. Offerors may submit more than one Offer, provided that each Offer has significant differences other than price. Each separate Offer must satisfy all Solicitation requirements. If this solicitation is an Invitation for Bids, each separate offer must be submitted as a separate document. If this solicitation is a Request for Proposals, multiple offers may be submitted as one document, provided that you clearly differentiate between each offer and you submit a separate cost proposal for each offer, if applicable.
- (c) Responsiveness. Any Offer which fails to conform to the material requirements of the Solicitation may be rejected as nonresponsive. Offers which impose conditions that modify material requirements of the Solicitation may be rejected. If a fixed price is required, an Offer will be rejected if the total possible cost to the State cannot be determined. Offerors will not be given an opportunity to correct any material nonconformity. Any deficiency resulting from a minor informality may be cured or waived at the sole discretion of the Procurement Officer. [R.19-445.2070 and Section 11-35-1520(13)]
- (d) Price Reasonableness: Any offer may be rejected if the Procurement Officer determines in writing that it is unreasonable as to price. [R. 19-445.2070].
- (e) Unbalanced Bidding. The State may reject an Offer as nonresponsive if the prices bid are materially unbalanced between line items or subline items. A bid is materially unbalanced when it is based on prices significantly less than cost for some work and prices which are significantly overstated in relation to cost for other work, and if there is a reasonable doubt that the bid will result in the lowest overall cost to the State even though it may be the low evaluated bid, or if it is so unbalanced as to be tantamount to allowing an advance payment.
- (f) **Do not submit bid samples or descriptive literature unless expressly requested.** Unsolicited bid samples or descriptive literature will not be examined or tested, will not be used to determine responsiveness, and will not be deemed to vary any of the provisions of the solicitation. S.C. Code Ann. Reg. 19-445.2077(D).

SIGNING YOUR OFFER (JAN 2004)

Every Offer must be signed by an individual with actual authority to bind the Offeror. (a) If the Offeror is an individual, the Offer must be signed by that individual. If the Offeror is an individual doing business as a firm, the Offer must be submitted in the firm name, signed by the individual, and state that the individual is doing business as a firm. (b) If the Offeror is a partnership, the Offer must be submitted in the partnership name, followed by the words "by its Partner," and signed by a general partner. (c) If the Offeror is a corporation, the Offer must be submitted in the corporate name, followed by the signature and title of the person authorized to sign. (d) An Offer may be submitted by a joint venturer involving any combination of individuals, partnerships, or corporations. If the Offeror is a joint venture, the Offer must be submitted in the name of the Joint Venture and signed by every participant in the joint venture in the manner prescribed in paragraphs (a) through (c) above for each type of participant. (e) If an Offer is signed by an agent, other than as stated in subparagraphs (a) through (d) above, the Offer must state that it has been signed by an Agent. Upon request, Offeror must provide proof of the agent's authorization to bind the principal.

STATE OFFICE CLOSINGS (JAN 2004)

If an emergency or unanticipated event interrupts normal government processes so that offers cannot be received at the government office designated for receipt of bids by the exact time specified in the solicitation, the time specified for receipt of offers will be deemed to be extended to the same time of day specified in the solicitation on the first work day on which normal government processes resume. In lieu of an automatic extension, an Amendment may be issued to reschedule bid opening. If state offices are closed at the time a pre-bid or pre-proposal conference is scheduled, an Amendment will be issued to reschedule the conference. Useful information may be available at: <http://www.scemd.org/planandprepare/disasters/severe-winter-weather>

SUBMITTING CONFIDENTIAL INFORMATION (FEB 2015)

(An overview is available at www.procurement.sc.gov) For every document Offeror submits in response to or with regard to this solicitation or request, Offeror must separately mark with the word "CONFIDENTIAL" every page, or portion thereof, that Offeror contends contains information that is exempt from public disclosure because it is either (a) a trade secret as defined in Section 30-4-40(a)(1), or (b) privileged and confidential, as that phrase is used in Section 11-35-410. For every document Offeror submits in response to or with regard to this solicitation or request, Offeror must separately mark with the words "TRADE SECRET" every page, or portion thereof, that Offeror contends contains a trade secret as that term is defined by Section 39-8-20 of the Trade Secrets Act. For every document Offeror submits in response to or with regard to this solicitation or request, Offeror must separately

mark with the word "PROTECTED" every page, or portion thereof, that Offeror contends is protected by Section 11-35-1810. All markings must be conspicuous; use color, bold, underlining, or some other method in order to conspicuously distinguish the mark from the other text. Do not mark your entire response (bid, proposal, quote, etc.) as confidential, trade secret, or protected. If your response, or any part thereof, is improperly marked as confidential or trade secret or protected, the State may, in its sole discretion, determine it nonresponsive. If only portions of a page are subject to some protection, do not mark the entire page. By submitting a response to this solicitation or request, Offeror (1) agrees to the public disclosure of every page of every document regarding this solicitation or request that was submitted at any time prior to entering into a contract (including, but not limited to, documents contained in a response, documents submitted to clarify a response, and documents submitted during negotiations), unless the page is conspicuously marked "TRADE SECRET" or "CONFIDENTIAL" or "PROTECTED", (2) agrees that any information not marked, as required by these bidding instructions, as a "Trade Secret" is not a trade secret as defined by the Trade Secrets Act, and (3) agrees that, notwithstanding any claims or markings otherwise, any prices, commissions, discounts, or other financial figures used to determine the award, as well as the final contract amount, are subject to public disclosure. In determining whether to release documents, the State will detrimentally rely on Offeror's marking of documents, as required by these bidding instructions, as being either "Confidential" or "Trade Secret" or "PROTECTED". By submitting a response, Offeror agrees to defend, indemnify and hold harmless the State of South Carolina, its agencies, officers and employees, from every claim, demand, loss, expense, cost, damage or injury, including attorney's fees, arising out of or resulting from withholding information by the State of South Carolina or any of its agencies, that Offeror marked as "confidential" or "trade secret" or "PROTECTED". (All references to S.C. Code of Laws.)

SUBMITTING A PAPER OFFER OR MODIFICATION

Paper offers are required. (a) All prices and notations should be printed in ink or typewritten. Errors should be crossed out, corrections entered and initialed by the person signing the bid. Do not modify the solicitation document itself (including bid schedule). (b) (1) All copies of the offer or modification, and any other documents required to be submitted with the offer shall be enclosed in a sealed, opaque envelope or package. (2) Submit your offer or modification to the address on the Cover Page. (3) The envelope or package must show the time and date specified for opening, the solicitation number, and the name and address of the bidder. If the offer or modification is sent by mail or special delivery service (UPS, Federal Express, etc.), the outermost envelope or wrapper must be labeled "OFFER ENCLOSED" on the face thereof. (c) If you are responding to more than one solicitation, submit each offer in a separate envelope or package. (d) Submit the number of copies indicated on the Cover Page. (e) Facsimile or e-mail offers, modifications, or withdrawals, will not be considered unless authorized by the Solicitation.

TAX CREDIT FOR SUBCONTRACTING WITH DISADVANTAGED SMALL BUSINESSES (JAN 2008)

Pursuant to Section 12-6-3350, a taxpayer having a contract with this State who subcontracts with a socially and economically disadvantaged small business is eligible for an income tax credit equal to four percent of the payments to that subcontractor for work pursuant to the contract. The subcontractor must be certified as a socially and economically disadvantaged small business as defined in Section 11-35-5010 and regulations pursuant to it. The credit is limited to a maximum of fifty thousand dollars annually. A taxpayer is eligible to claim the credit for ten consecutive taxable years beginning with the taxable year in which the first payment is made to the subcontractor that qualifies for the credit. After the above ten consecutive taxable years, the taxpayer is no longer eligible for the credit. A taxpayer claiming the credit shall maintain evidence of work performed for the contract by the subcontractor. The credit may be claimed on Form TC-2, "Minority Business Credit." A copy of the subcontractor's certificate from the Governor's Office of Small and Minority Business (OSMBA) is to be attached to the contractor's income tax return. Questions regarding the tax credit and how to file are to be referred to: SC Department of Revenue, Research and Review, Phone: (803) 898-5786, Fax: (803) 898-5888. Questions regarding subcontractor certification are to be referred to: Governor's Office of Small and Minority Business Assistance, Phone: (803) 734-0657, Fax: (803) 734-2498.

TAXPAYER IDENTIFICATION NUMBER

(a) If Offeror is owned or controlled by a common parent as defined in paragraph (b) of this provision, Offeror shall submit with its Offer the name and TIN of common parent.

(b) Definitions: "Common parent," as used in this provision, means that corporate entity that owns or controls an affiliated group of corporations that files its Federal income tax returns on a consolidated basis, and of which the offeror is a member. "Taxpayer Identification Number (TIN)," as used in this provision, means the number required by the Internal Revenue Service (IRS) to be used by the offeror in reporting income tax and other returns. The TIN may be either a Social Security Number or an Employer Identification Number.

(c) If Offeror does not have a TIN, Offeror shall indicate if either a TIN has been applied for or a TIN is not required. If a TIN is not required, indicate whether (i) Offeror is a nonresident alien, foreign corporation, or foreign partnership that does not have income effectively connected with the conduct of a trade or business in the United States and does not have an office or place of business or a fiscal paying agent in the United States; (ii) Offeror is an agency or instrumentality of a state or local government; (iii) Offeror is an agency or instrumentality of a foreign government; or (iv) Offeror is an agency or instrumentality of the Federal Government.

WITHDRAWAL OR CORRECTION OF OFFER (JAN 2004)

Offers may be withdrawn by written notice received at any time before the exact time set for opening. If the Solicitation authorizes facsimile offers, offers may be withdrawn via facsimile received at any time before the exact time set for opening. A bid may be withdrawn in person by a bidder or its authorized representative if, before the exact time set for opening, the identity of the person requesting withdrawal is established and the person signs a receipt for the bid. The withdrawal and correction of Offers is governed by S.C. Code Section 11-35-1520 and Regulation 19-445.2085.

II. INSTRUCTIONS TO OFFERORS -- B. SPECIAL INSTRUCTIONS

CLARIFICATION (NOV 2007)

Pursuant to Section 11-35-1520(8), the Procurement Officer may elect to communicate with you after opening for the purpose of clarifying either your offer or the requirements of the solicitation. Such communications may be conducted only with offerors who have submitted an offer which obviously conforms in all material aspects to the solicitation. Clarification of an offer must be documented in writing and included with the offer. Clarifications may not be used to revise an offer or the solicitation. [Section 11-35-1520(8); R.19-445.2080]

DESCRIPTIVE LITERATURE – LABELLING (JAN 2006)

Include offeror's name on the cover of any specifications or descriptive literature submitted with your offer.

PROTEST - CPO - MMO ADDRESS (JUN 2006)

Any protest must be addressed to the Chief Procurement Officer, Materials Management Office, and submitted in writing

(a) by email to protest-mmo@mmo.state.sc.us,

(b) by facsimile at 803-737-0639, or

(c) by post or delivery to 1201 Main Street, Suite 600, Columbia, SC 29201.

UNIT PRICES REQUIRED (JAN 2006)

Unit price to be shown for each item.

DISCUSSIONS WITH BIDDERS

After opening, the Procurement Officer may, in his sole discretion, initiate discussions with you to discuss your bid. Discussions are possible only if your bid is apparently responsive and only for the purpose of clarification to assure your full understanding of the solicitation's requirements. Any discussions will be documented in writing and shall be included with the bid.

ELECTRONIC COPIES – REQUIRED MEDIA AND FORMAT

In addition to your original offer, you must submit an electronic copy on a USB drive. Submit the number of copies indicated on the cover page. Each copy should be on separate media. Your business and technical proposals must be on separate media. Every disk or USB drive must be labeled with the solicitation number and the offeror's name, and specify whether its contents address technical proposal or business proposal. If multiple-disk sets are provided, each disk in the set must be appropriately identified as to its relationship to the set, e.g., 1 of 2. The electronic copy must be identical to the original offer. File format shall be compatible with Microsoft Office (version 2003 or later), or Adobe Acrobat or equivalent Portable Document Format (.pdf) viewer. The Procurement Officer must be able to view, search, copy and print electronic documents without a password.

OFFERING BY LOT (JAN 2006)

Offers may be submitted for one or more complete lots. Failure to offer on all items within a lot will be reason for rejection.

III. SCOPE OF WORK/SPECIFICATIONS

STATEMENT OF WORK (JUN 2007)

Please see **ATTACHMENT A** for STATEMENT OF WORK.

DELIVERY / PERFORMANCE LOCATION – PURCHASE ORDER (JAN 2006)

After award, all deliveries shall be made and all services provided to the location specified by the Using Governmental Unit in its purchase order.

QUALITY – NEW (JAN 2006)

All items must be new.

IV. INFORMATION FOR OFFERORS TO SUBMIT

INFORMATION FOR OFFERORS TO SUBMIT – GENERAL

You shall submit a signed Cover Page and Page Two. Your offer should include all other information and documents requested in this part and in parts II.B. Special Instructions; III. Scope of Work; V. Qualifications; VIII. Bidding Schedule/Price Proposal; and any appropriate attachments addressed in Part IX. Attachments to Solicitations. You should submit a summary of all insurance policies you have or plan to acquire to comply with the insurance requirements stated herein, if any, including policy types; coverage types; limits, sub-limits, and deductibles for each policy and coverage type; the carrier's A.M. Best rating; and whether the policy is written on an occurrence or claims-made basis.

MINORITY PARTICIPATION (JAN 2006)

Is the bidder a South Carolina Certified Minority Business? Yes NO

Is the bidder a Minority Business certified by another governmental entity? Yes NO

If so, please list the certifying governmental entity: _____

Will any of the work under this contract be performed by a SC certified Minority Business as a subcontractor? Yes NO

If so, what percentage of the total value of the contract will be performed by a SC certified Minority Business as a subcontractor? Yes NO

Will any of the work under this contract be performed by a minority business certified by another governmental entity as a subcontractor? Yes NO

If so, what percentage of the total value of the contract will be performed by a minority business certified by another governmental entity as a subcontractor? Yes NO

If a certified Minority Business is participating in this contract, please indicate all categories for which the Business is certified:

- Traditional minority
- Traditional minority, but female
- Women (Caucasian females)
- Hispanic minorities
- DOT referral (Traditional minority)
- DOT referral (Caucasian female)
- Temporary certification
- SBA 8 (a) certification referral
- Other minorities (Native American, Asian, etc.)

(If more than one minority contractor will be utilized in the performance of this contract, please provide the information above for each minority business.)

V. QUALIFICATIONS

QUALIFICATION OF OFFEROR (MAR 2015)

(1) To be eligible for award, you must have the capability in all respects to perform fully the contract requirements and the integrity and reliability which will assure good faith performance. We may also consider a documented commitment from a satisfactory source that will provide you with a capability. We may consider information from any source at any time prior to award. We may elect to consider (i) key personnel, any predecessor business, and any key personnel of any predecessor business, including any facts arising prior to the date a business was established, and/or (ii) any subcontractor you identify. (2) You must promptly furnish satisfactory evidence of responsibility upon request. Unreasonable failure to supply requested information is grounds for rejection. (3) **Corporate subsidiaries are cautioned that the financial capability of an affiliated or parent company will not be considered in determining financial capability;** however, we may elect to consider any security, e.g., letter of credit, performance bond, parent-company corporate guaranty, that you offer to provide Instructions and forms to help assure acceptability are posted on procurement.sc.gov, link to "Standard Clauses & Provisions."

SUBCONTRACTOR – IDENTIFICATION (FEB 2015)

If you intend to subcontract, at any tier level, with another business for any portion of the work and that portion either (1) exceeds 10% of your cost, (2) involves access to any "government information," as defined in the clause entitled "Information Security - Definitions," if included, or (3) otherwise involves services critical to your performance of the work (err **on the** side of inclusion), your offer must identify that business and the work which they are to perform. Identify potential subcontractors by providing the business name, address, phone, taxpayer identification number, and point of contact. In determining your responsibility, the state may contact and evaluate your proposed subcontractors.

VI. AWARD CRITERIA

AWARD CRITERIA – BIDS (JAN 2006)

Award will be made to the lowest responsible and responsive bidder(s).

AWARD TO ONE OFFEROR (JAN 2006)

Award will be made to one Offeror.

UNIT PRICE GOVERNS (JAN 2006)

In determining award, unit prices will govern over extended prices unless otherwise stated.

AWARD BY LOT (JAN 2006)

Award will be made by complete lot(s).

VII. TERMS AND CONDITIONS -- A. GENERAL

ASSIGNMENT, NOVATION, AND CHANGE OF NAME, IDENTITY, OR STRUCTURE (FEB 2015)

(a) Contractor shall not assign this contract, or its rights, obligations, or any other interest arising from this contract, or delegate any of its performance obligations, without the express written consent of the responsible procurement officer. The foregoing restriction does not apply to a transfer that occurs by operation of law (e.g., bankruptcy; corporate reorganizations and consolidations, but not including partial asset sales). Notwithstanding the foregoing, contractor may assign monies receivable under the contract provided that the state shall have no obligation to make payment to an assignee until thirty days after contractor (not the assignee) has provided the responsible procurement officer with (i) proof of the assignment, (ii) the identity (by contract number) of the specific state contract to which the assignment applies, and (iii) the name of the assignee and the exact address or account information to which assigned payments should be made. (b) If contractor amends, modifies, or otherwise changes its name, its identity (including its trade name), or its corporate, partnership or other structure, or its FEIN, contractor shall provide the procurement officer prompt written notice of such change. (c) Any name change, transfer, assignment, or novation is subject to the conditions and approval required by Regulation 19-445.2180, which does not restrict transfers by operation of law.

BANKRUPTCY - GENERAL (FEB 2015)

(a) Notice. In the event the Contractor enters into proceedings relating to bankruptcy, whether voluntary or involuntary, the Contractor agrees to furnish written notification of the bankruptcy to the Using Governmental Unit. This notification shall be furnished within two (2) days of the initiation of the proceedings relating to the bankruptcy filing. This notification shall include the date on which the bankruptcy petition was filed, the identity of the court in which the bankruptcy petition was filed, and a listing of all State contracts against which final payment has not been made. This obligation remains in effect until final payment under this Contract. (b) Termination. This contract is voidable and subject to immediate termination by the State upon the contractor's insolvency, including the filing of proceedings in bankruptcy.

CHOICE-OF-LAW (JAN 2006)

The Agreement, any dispute, claim, or controversy relating to the Agreement, and all the rights and obligations of the parties shall, in all respects, be interpreted, construed, enforced and governed by and under the laws of the State of South Carolina, except its choice of law rules. As used in this paragraph, the term "Agreement" means any transaction or agreement arising out of, relating to, or contemplated by the solicitation.

CONTRACT DOCUMENTS & ORDER OF PRECEDENCE (FEB 2015)

(a) Any contract resulting from this solicitation shall consist of the following documents: (1) a Record of Negotiations, if any, executed by you and the Procurement Officer, (2) the solicitation, as amended, (3) documentation of clarifications [11-35-1520(8)] or discussions [11-35-1530(6)] of an offer, if applicable, (4) your offer, (5) any statement reflecting the state's final acceptance (a/k/a "award"), and (6) purchase orders. These documents shall be read to be consistent and complimentary. Any conflict among these documents shall be resolved by giving priority to these documents in the order listed above.

(b) The terms and conditions of documents (1) through (5) above shall apply notwithstanding any additional or different terms and conditions in any other document, including without limitation, (i) a purchase order or other instrument submitted by the State, (ii) any invoice or other document submitted by Contractor, or (iii) any privacy policy, terms of use, or end user agreement. Except as otherwise allowed herein, the terms and conditions of all such documents shall be void and of no effect.

(c) No contract, license, or other agreement containing contractual terms and conditions will be signed by any Using Governmental Unit. Any document signed or otherwise agreed to by persons other than the Procurement Officer shall be void and of no effect.

DISCOUNT FOR PROMPT PAYMENT (JAN 2006)

(a) Discounts for prompt payment will not be considered in the evaluation of offers. However, any offered discount will form a part of the award, and will be taken if payment is made within the discount period indicated in the offer by the offeror. As an alternative to offering a discount for prompt payment in conjunction with the offer, offerors awarded contracts may include discounts for prompt payment on individual invoices.

(b) In connection with any discount offered for prompt payment, time shall be computed from the date of the invoice. If the Contractor has not placed a date on the invoice, the due date shall be calculated from the date the

designated billing office receives a proper invoice, provided the state annotates such invoice with the date of receipt at the time of receipt. For the purpose of computing the discount earned, payment shall be considered to have been made on the date that appears on the payment check or, for an electronic funds transfer, the specified payment date. When the discount date falls on a Saturday, Sunday, or legal holiday when Federal Government offices are closed and Government business is not expected to be conducted, payment may be made on the following business day.

DISPUTES (JAN 2006)

(1) Choice-of-Forum. All disputes, claims, or controversies relating to the Agreement shall be resolved exclusively by the appropriate Chief Procurement Officer in accordance with Title 11, Chapter 35, Article 17 of the South Carolina Code of Laws, or in the absence of jurisdiction, only in the Court of Common Pleas for, or a federal court located in, Richland County, State of South Carolina. Contractor agrees that any act by the Government regarding the Agreement is not a waiver of either the Government's sovereign immunity or the Government's immunity under the Eleventh Amendment of the United State's Constitution. As used in this paragraph, the term "Agreement" means any transaction or agreement arising out of, relating to, or contemplated by the solicitation. (2) Service of Process. Contractor consents that any papers, notices, or process necessary or proper for the initiation or continuation of any disputes, claims, or controversies relating to the Agreement; for any court action in connection therewith; or for the entry of judgment on any award made, may be served on Contractor by certified mail (return receipt requested) addressed to Contractor at the address provided as the Notice Address on Page Two or by personal service or by any other manner that is permitted by law, in or outside South Carolina. Notice by certified mail is deemed duly given upon deposit in the United States mail.

EQUAL OPPORTUNITY (JAN 2006)

Contractor is referred to and shall comply with all applicable provisions, if any, of Title 41, Part 60 of the Code of Federal Regulations, including but not limited to Sections 60-1.4, 60-4.2, 60-4.3, 60-250.5(a), and 60-741.5(a), which are hereby incorporated by reference.

FALSE CLAIMS (JAN 2006)

According to the S.C. Code of Laws § 16-13-240, "a person who by false pretense or representation obtains the signature of a person to a written instrument or obtains from another person any chattel, money, valuable security, or other property, real or personal, with intent to cheat and defraud a person of that property is guilty" of a crime.

FIXED PRICING REQUIRED (JAN 2006)

Any pricing provided by contractor shall include all costs for performing the work associated with that price. Except as otherwise provided in this solicitation, contractor's price shall be fixed for the duration of this contract, including option terms. This clause does not prohibit contractor from offering lower pricing after award.

IRAN DIVESTMENT ACT – ONGOING OBLIGATIONS – (JAN 2015)

(a) You must notify the procurement officer immediately if, at any time during the contract term, you are added to the Iran Divestment Act List. (b) Consistent with Section 11-57-330(B), you shall not contract with any person to perform a part of the Work, if at the time you enter into the subcontract, that person is on the then-current version of the Iran Divestment Act List.

NO INDEMNITY OR DEFENSE (FEB 2015)

Any term or condition is void to the extent it requires the State to indemnify, defend, or pay attorney's fees to anyone for any reason.

NOTICE (JAN 2006)

(A) After award, any notices shall be in writing and shall be deemed duly given (1) upon actual delivery, if delivery is by hand, (2) upon receipt by the transmitting party of automated confirmation or answer back from the recipient's device if delivery is by telex, telegram, facsimile, or electronic mail, or (3) upon deposit into the United States mail, if postage is prepaid, a return receipt is requested, and either registered or certified mail is used. (B) Notice to contractor shall be to the address identified as the Notice Address on Page Two. Notice to the state shall be to the Procurement Officer's address on the Cover Page. Either party may designate a different address for notice by giving notice in accordance with this paragraph.

OPEN TRADE (JUN 2015)

During the contract term, including any renewals or extensions, Contractor will not engage in the boycott of a person or an entity based in or doing business with a jurisdiction with whom South Carolina can enjoy open trade, as defined in SC Code Section 11-35-5300.

PAYMENT & INTEREST (FEB 2015)

(a) The State shall pay the Contractor, after the submission of proper invoices or vouchers, the prices stipulated in this contract for supplies delivered and accepted or services rendered and accepted, less any deductions provided in this contract. Unless otherwise specified herein, including the purchase order, payment shall not be made on partial deliveries accepted by the Government. (b) Unless otherwise provided herein, including the purchase order, payment will be made by check mailed to the payment address on "Page Two." (c) Notwithstanding any other provision, payment shall be made in accordance with S.C. Code Section 11-35-45, or Chapter 6 of Title 29 (real property improvements) when applicable, which provides the Contractor's exclusive means of recovering any type of interest from the Owner. Contractor waives imposition of an interest penalty unless the invoice submitted specifies that the late penalty is applicable. Except as set forth in this paragraph, the State shall not be liable for the payment of interest on any debt or claim arising out of or related to this contract for any reason. (d) Amounts due to the State shall bear interest at the rate of interest established by the South Carolina Comptroller General pursuant to Section 11-35-45 ("an amount not to exceed fifteen percent each year"), as amended, unless otherwise required by Section 29-6-30. (e) Any other basis for interest, including but not limited to general (pre- and post-judgment) or specific interest statutes, including S.C. Code Ann. Section 34-31-20, are expressly waived by both parties. If a court, despite this agreement and waiver, requires that interest be paid on any debt by either party other than as provided by items (c) and (d) above, the parties further agree that the applicable interest rate for any given calendar year shall be the lowest prime rate as listed in the first edition of the Wall Street Journal published for each year, applied as simple interest without compounding. (f) The State shall have all of its common law, equitable and statutory rights of set-off.

PUBLICITY (JAN 2006)

Contractor shall not publish any comments or quotes by State employees, or include the State in either news releases or a published list of customers, without the prior written approval of the Procurement Officer.

PURCHASE ORDERS (JAN 2006)

Contractor shall not perform any work prior to the receipt of a purchase order from the using governmental unit. The using governmental unit shall order any supplies or services to be furnished under this contract by issuing a purchase order. Purchase orders may be used to elect any options available under this contract, e.g., quantity, item, delivery date, payment method, but are subject to all terms and conditions of this contract. Purchase orders may be electronic. No particular form is required. An order placed pursuant to the purchasing card provision qualifies as a purchase order.

SURVIVAL OF OBLIGATIONS (JAN 2006)

The Parties' rights and obligations which, by their nature, would continue beyond the termination, cancellation, rejection, or expiration of this contract shall survive such termination, cancellation, rejection, or expiration, including, but not limited to, the rights and obligations created by the following clauses: Indemnification - Third Party Claims, Intellectual Property Indemnification, and any provisions regarding warranty or audit.

TAXES (JAN 2006)

Any tax the contractor may be required to collect or pay upon the sale, use or delivery of the products shall be paid by the State, and such sums shall be due and payable to the contractor upon acceptance. Any personal property taxes levied after delivery shall be paid by the State. It shall be solely the State's obligation, after payment to contractor, to challenge the applicability of any tax by negotiation with, or action against, the taxing authority. Contractor agrees to refund any tax collected, which is subsequently determined not to be proper and for which a refund has been paid to contractor by the taxing authority. In the event that the contractor fails to pay, or delays in paying, to any taxing authorities, sums paid by the State to contractor, contractor shall be liable to the State for any loss (such as the assessment of additional interest) caused by virtue of this failure or delay. Taxes based on Contractor's net income or assets shall be the sole responsibility of the contractor.

TERMINATION DUE TO UNAVAILABILITY OF FUNDS (JAN 2006)

Payment and performance obligations for succeeding fiscal periods shall be subject to the availability and appropriation of funds therefore. When funds are not appropriated or otherwise made available to support continuation of performance in a subsequent fiscal period, the contract shall be canceled. In the event of a cancellation pursuant to this paragraph, contractor will be reimbursed the resulting unamortized, reasonably incurred, nonrecurring costs. Contractor will not be reimbursed any costs amortized beyond the initial contract term.

THIRD PARTY BENEFICIARY (JAN 2006)

This Contract is made solely and specifically among and for the benefit of the parties hereto, and their respective successors and assigns, and no other person will have any rights, interest, or claims hereunder or be entitled to any benefits under or on account of this Contract as a third party beneficiary or otherwise.

WAIVER (JAN 2006)

The State does not waive any prior or subsequent breach of the terms of the Contract by making payments on the Contract, by failing to terminate the Contract for lack of performance, or by failing to strictly or promptly insist upon any term of the Contract. Only the Procurement Officer has actual authority to waive any of the State's rights under this Contract. Any waiver must be in writing.

VII. TERMS AND CONDITIONS -- B. SPECIAL

HIPAA LAW

The Contractor agrees that to the extent that some or all of the activities within the scope of this Contract are subject to the Health Insurance Portability Accountability Act of 1996, P.L. 104-91, as amended ("HIPAA"), or its implementing regulations, it will comply with the HIPAA requirements and will execute such agreements and practices as the University of South Carolina may require to ensure compliance. Additional information may be viewed at: <http://www.sa.sc.edu/shs/hipaa>

BANKRUPTCY – GOVERNMENT INFORMATION (FEB 2015)

(a) All government information (as defined in the clause herein entitled "Information Security - Definitions") shall belong exclusively to the State, and Contractor has no legal or equitable interest in, or claim to, such information. Contractor acknowledges and agrees that in the event Contractor enters into proceedings relating to bankruptcy, whether voluntary or involuntary, government information in its possession and/or under its control will not be considered property of its bankruptcy estate.

(b) Contractor agrees to notify the State within forty-eight (48) hours of any determination that it makes to file for bankruptcy protection, and Contractor further agrees to turn over to the State, before such filing, all government information that is in Contractor's possession in a format that can be readily utilized by the State.

(c) In order to protect the integrity and availability of government information, Contractor shall take reasonable measures to evaluate and monitor the financial circumstances of any subcontractor that will process, store, transmit or access government information.

CHANGES (JAN 2006)

(1) Contract Modification. By a written order, at any time, and without notice to any surety, the Procurement Officer may, subject to all appropriate adjustments, make changes within the general scope of this contract in any one or more of the following:

(a) drawings, designs, or specifications, if the supplies to be furnished are to be specially manufactured for the [State] in accordance therewith;

(b) method of shipment or packing;

(c) place of delivery;

(d) description of services to be performed;

(e) time of performance (i.e., hours of the day, days of the week, etc.); or,

(f) place of performance of the services. Subparagraphs (a) to (c) apply only if supplies are furnished under this contract. Subparagraphs (d) to (f) apply only if services are performed under this contract.

(2) Adjustments of Price or Time for Performance. If any such change increases or decreases the contractor's cost of, or the time required for, performance of any part of the work under this contract, whether or not changed by the order, an adjustment shall be made in the contract price, the delivery schedule, or both, and the contract modified in writing accordingly. Any adjustment in contract price made pursuant to this clause shall be determined in accordance with the Price Adjustment Clause of this contract. Failure of the parties to agree to an adjustment shall not excuse the contractor from proceeding with the contract as changed, provided that the State promptly and duly make such provisional adjustments in payment or time for performance as may be reasonable. By proceeding with the work, the contractor shall not be deemed to have prejudiced any claim for additional compensation, or an extension of time for completion.

(3) Time Period for Claim. Within 30 days after receipt of a written contract modification under Paragraph (1) of this clause, unless such period is extended by the Procurement Officer in writing, the contractor shall file notice of intent to assert a claim for an adjustment. Later notification shall not bar the contractor's claim unless the State is prejudiced by the delay in notification.

(4) Claim Barred After Final Payment. No claim by the contractor for an adjustment hereunder shall be allowed if notice is not given prior to final payment under this contract.

CISG (JAN 2006)

The parties expressly agree that the UN Convention on the International Sale of Goods shall not apply to this agreement.

COMPLIANCE WITH LAWS (JAN 2006)

During the term of the contract, contractor shall comply with all applicable provisions of laws, codes, ordinances, rules, regulations, and tariffs.

CONTRACTOR'S LIABILITY INSURANCE - GENERAL (FEB 2015)

(a) Without limiting any of the obligations or liabilities of Contractor, Contractor shall procure from a company or companies lawfully authorized to do business in South Carolina and with a current A.M. Best rating of no less than A: VII, and maintain for the duration of the contract, insurance against claims for injuries to persons or damages to property which may arise from or in connection with the performance of the work and the results of that work by the contractor, his agents, representatives, employees or subcontractors.

(b) Coverage shall be at least as broad as:

(1) Commercial General Liability (CGL): Insurance Services Office (ISO) Form CG 00 01 12 07 covering CGL on an "occurrence" basis, including products-completed operations, personal and advertising injury, with limits no less than \$1,000,000 per occurrence. If a general aggregate limit applies, the general aggregate limit shall be twice the required occurrence limit. This contract shall be considered to be an "insured contract" as defined in the policy.

(2) Auto Liability: ISO Form Number CA 00 01 covering any auto (Code 1), or if Contractor has no owned autos, hired, (Code 8) and non-owned autos (Code 9), with limits no less than \$1,000,000 per accident for bodily injury and property damage.

(3) Worker's Compensation: As required by the State of South Carolina, with Statutory Limits, and Employer's Liability Insurance with limit of no less than \$1,000,000 per accident for bodily injury or disease.

(c) Every applicable Using Governmental Unit, and the officers, officials, employees and volunteers of any of them, must be covered as additional insureds on the CGL policy with respect to liability arising out of work or operations performed by or on behalf of the Contractor including materials, parts or equipment furnished in connection with such work or operations. General liability coverage can be provided in the form of an endorsement to the Contractor's insurance at least as broad as ISO Form CG 20 10 11 85 or if not available, through the addition of both CG 20 10 and CG 20 37 if a later edition is used.

(d) For any claims related to this contract, the Contractor's insurance coverage shall be primary insurance as respects the State, every applicable Using Governmental Unit, and the officers, officials, employees and volunteers of any of them. Any insurance or self-insurance maintained by the State, every applicable Using Governmental Unit, or the officers, officials, employees and volunteers of any of them, shall be excess of the Contractor's insurance and shall not contribute with it.

(e) Prior to commencement of the work, the Contractor shall furnish the State with original certificates and amendatory endorsements or copies of the applicable policy language effecting coverage required by this section. All certificates are to be received and approved by the State before work commences. However, failure to obtain the required documents prior to the work beginning shall not waive the Contractor's obligation to provide them. The State reserves the right to require complete, certified copies of all required insurance policies, including endorsements required by this section, at any time.

(f) Should any of the above described policies be cancelled before the expiration date thereof, notice will be delivered in accordance with the policy provisions. In addition, the Contractor shall notify the State immediately upon receiving any information that any of the coverages required by this section are or will be changed, cancelled, or replaced.

(g) Contractor hereby grants to the State and every applicable Using Governmental Unit a waiver of any right to subrogation which any insurer of said Contractor may acquire against the State or applicable Using Governmental Unit by virtue of the payment of any loss under such insurance. Contractor agrees to obtain any endorsement that may be necessary to effect this waiver of subrogation, but this provision applies regardless of whether or not the State or Using Governmental Unit has received a waiver of subrogation endorsement from the insurer.

(h) Any deductibles or self-insured retentions must be declared to and approved by the State. The State may require the Contractor to purchase coverage with a lower deductible or retention or provide proof of ability to pay losses and related investigations, claim administration, and defense expenses within the retention.

(i) The State reserves the right to modify these requirements, including limits, based on the nature of the risk, prior experience, insurer, coverage, or other special circumstances.

Insurance Requirements: Successful bidder must provide a copy of its liability insurance certificate within ten (10) days upon the posting of the intent to award statement or award statement and on each contract anniversary date thereafter attesting to such insurance coverage.

CONTRACTOR PERSONNEL (JAN 2006)

The Contractor shall enforce strict discipline and good order among the Contractor's employees and other persons carrying out the Contract. The Contractor shall not permit employment of unfit persons or persons not skilled in tasks assigned to them.

CONTRACTOR'S OBLIGATION – GENERAL (JAN 2006)

The contractor shall provide and pay for all materials, tools, equipment, labor and professional and non-professional services, and shall perform all other acts and supply all other things necessary, to fully and properly perform and complete the work. The contractor must act as the prime contractor and assume full responsibility for any subcontractor's performance. The contractor will be considered the sole point of contact with regard to all situations, including payment of all charges and the meeting of all other requirements.

DEFAULT (JAN 2006)

(a) (1) The State may, subject to paragraphs (c) and (d) of this clause, by written notice of default to the Contractor, terminate this contract in whole or in part if the Contractor fails to:

- (i) Deliver the supplies or to perform the services within the time specified in this contract or any extension;
- (ii) Make progress, so as to endanger performance of this contract (but see paragraph (a)(2) of this clause); or
- (iii) Perform any of the other material provisions of this contract (but see paragraph (a)(2) of this clause).

(2) The State's right to terminate this contract under subdivisions (a)(1)(ii) and (1)(iii) of this clause, may be exercised if the Contractor does not cure such failure within 10 days (or more if authorized in writing by the Procurement Officer) after receipt of the notice from the Procurement Officer specifying the failure.

(b) If the State terminates this contract in whole or in part, it may acquire, under the terms and in the manner the Procurement Officer considers appropriate, supplies or services similar to those terminated, and the Contractor will be liable to the State for any excess costs for those supplies or services. However, the Contractor shall continue the work not terminated.

(c) Except for defaults of subcontractors at any tier, the Contractor shall not be liable for any excess costs if the failure to perform the contract arises from causes beyond the control and without the fault or negligence of the Contractor. Examples of such causes include (1) acts of God or of the public enemy, (2) acts of the State in either its sovereign or contractual capacity, (3) fires, (4) floods, (5) epidemics, (6) quarantine restrictions, (7) strikes, (8) freight embargoes, and (9) unusually severe weather. In each instance the failure to perform must be beyond the control and without the fault or negligence of the Contractor.

(d) If the failure to perform is caused by the default of a subcontractor at any tier, and if the cause of the default is beyond the control of both the Contractor and subcontractor, and without the fault or negligence of either, the Contractor shall not be liable for any excess costs for failure to perform, unless the subcontracted supplies or services were obtainable from other sources in sufficient time for the Contractor to meet the required delivery schedule.

(e) If this contract is terminated for default, the State may require the Contractor to transfer title and deliver to the State, as directed by the Procurement Officer, any (1) completed supplies, and (2) partially completed supplies and materials, parts, tools, dies, jigs, fixtures, plans, drawings, information, and contract rights (collectively referred to as "manufacturing materials" in this clause) that the Contractor has specifically produced or acquired for the terminated portion of this contract. Upon direction of the Procurement Officer, the Contractor shall also protect and preserve property in its possession in which the State has an interest.

(f) The State shall pay contract price for completed supplies delivered and accepted. The Contractor and Procurement Officer shall agree on the amount of payment for manufacturing materials delivered and accepted and for the protection and preservation of the property; if the parties fail to agree, the Procurement Officer shall set an amount subject to the Contractor's rights under the Disputes clause. Failure to agree will be a dispute under the Disputes clause. The State may withhold from these amounts any sum the Procurement Officer determines to be necessary to protect the State against loss because of outstanding liens or claims of former lien holders.

(g) If, after termination, it is determined that the Contractor was not in default, or that the default was excusable, the rights and obligations of the parties shall, if the contract contains a clause providing for termination for convenience of the State, be the same as if the termination had been issued for the convenience of the State. If, in the foregoing circumstances, this contract does not contain a clause providing for termination for convenience of the State, the contract shall be adjusted to compensate for such termination and the contract modified accordingly subject to the contractor's rights under the Disputes clause.

(h) The rights and remedies of the State in this clause are in addition to any other rights and remedies provided by law or under this contract.

ILLEGAL IMMIGRATION (NOV 2008)

(An overview is available at www.procurement.sc.gov) By signing your offer, you certify that you will comply with the applicable requirements of Title 8, Chapter 14 of the South Carolina Code of Laws and agree to provide to the State upon request any documentation required to establish either: (a) that Title 8, Chapter 14 is inapplicable to you and your subcontractors or sub-subcontractors; or (b) that you and your subcontractors or sub-subcontractors are in compliance with Title 8, Chapter 14. Pursuant to Section 8-14-60, "A person who knowingly makes or files any false, fictitious, or fraudulent document, statement, or report pursuant to this chapter is guilty of a felony, and, upon conviction, must be fined within the discretion of the court or imprisoned for not more than five years, or both." You agree to include in any contracts with your subcontractors language requiring your subcontractors to (a) comply with the applicable requirements of Title 8, Chapter 14, and (b) include in their contracts with the sub-subcontractors language requiring the sub-subcontractors to comply with the applicable requirements of Title 8, Chapter 14.

INDEMNIFICATION-THIRD PARTY CLAIMS – GENERAL (NOV 2011)

Notwithstanding any limitation in this agreement, and to the fullest extent permitted by law, Contractor shall defend and hold harmless Indemnitees for and against any and all suits or claims of any character (and all related damages, settlement payments, attorneys' fees, costs, expenses, losses or liabilities) by a third party which are attributable to bodily injury, sickness, disease or death, or to injury to or destruction of tangible property arising out of or in connection with the goods or services acquired hereunder or caused in whole or in part by any act or omission of contractor, its subcontractors, their employees, workmen, servants, agents, or anyone directly or indirectly employed by them or anyone for whose acts any of them may be liable, regardless of whether or not caused in part by an Indemnitee, and whether or not such claims are made by a third party or an Indemnitee; however, if an Indemnitee's negligent act or omission is subsequently determined to be the sole proximate cause of a suit or claim, the Indemnitee shall not be entitled to indemnification hereunder. Contractor shall be given timely written notice of any suit or claim. Contractor's obligations hereunder are in no way limited by any protection afforded under workers' compensation acts, disability benefits acts, or other employee benefit acts. This clause shall not negate, abridge, or reduce any other rights or obligations of indemnity which would otherwise exist. The obligations of this paragraph shall survive termination, cancelation, or expiration of the parties' agreement. This provision shall be construed fairly and reasonably, neither strongly for nor against either party, and without regard to any clause regarding insurance. As used in this clause, "Indemnitees" means the State of South Carolina, its instrumentalities, agencies, departments, boards, political subdivisions and all their respective officers, agents and employees.

LICENSES AND PERMITS (JAN 2006)

During the term of the contract, the Contractor shall be responsible for obtaining, and maintaining in good standing, all licenses (including professional licenses, if any), permits, inspections and related fees for each or any such licenses, permits and /or inspections required by the State, county, city or other government entity or unit to accomplish the work specified in this solicitation and the contract.

MATERIAL AND WORKMANSHIP (JAN 2006)

Unless otherwise specifically provided in this contract, all equipment, material, and articles incorporated in the work covered by this contract are to be new and of the most suitable grade for the purpose intended.

PRICE ADJUSTMENTS (JAN 2006)

(1) Method of Adjustment. Any adjustment in the contract price made pursuant to a clause in this contract shall be consistent with this Contract and shall be arrived at through whichever one of the following ways is the most valid approximation of the actual cost to the Contractor (including profit, if otherwise allowed):

- (a) by agreement on a fixed price adjustment before commencement of the pertinent performance or as soon thereafter as practicable;
- (b) by unit prices specified in the Contract or subsequently agreed upon;
- (c) by the costs attributable to the event or situation covered by the relevant clause, including profit if otherwise allowed, all as specified in the Contract; or subsequently agreed upon;
- (d) in such other manner as the parties may mutually agree; or,
- (e) in the absence of agreement by the parties, through a unilateral initial written determination by the Procurement Officer of the costs attributable to the event or situation covered by the clause, including profit if otherwise allowed,

all as computed by the Procurement Officer in accordance with generally accepted accounting principles, subject to the provisions of Title 11, Chapter 35, Article 17 of the S.C. Code of Laws.

(2) Submission of Price or Cost Data. Upon request of the Procurement Officer, the contractor shall provide reasonably available factual information to substantiate that the price or cost offered, for any price adjustments is reasonable, consistent with the provisions of Section 11-35-1830.

PRICING DATA – AUDIT – INSPECTION (JAN 2006)

[Clause Included Pursuant to Section 11-35-1830, - 2210, & -2220] (a) Cost or Pricing Data. Upon Procurement Officer's request, you shall submit cost or pricing data, as defined by 48 C.F.R. Section 2.101 (2004), prior to either (1) any award to contractor pursuant to 11-35-1530 or 11-35-1560, if the total contract price exceeds \$500,000, or (2) execution of a change order or contract modification with contractor which exceeds \$100,000. Your price, including profit or fee, shall be adjusted to exclude any significant sums by which the state finds that such price was increased because you furnished cost or pricing data that was inaccurate, incomplete, or not current as of the date agreed upon between parties. (b) Records Retention. You shall maintain your records for three years from the date of final payment, or longer if requested by the chief Procurement Officer. The state may audit your records at reasonable times and places. As used in this subparagraph (b), the term "records" means any books or records that relate to cost or pricing data submitted pursuant to this clause. In addition to the obligation stated in this subparagraph (b), you shall retain all records and allow any audits provided for by 11-35-2220(2). (c) Inspection. At reasonable times, the state may inspect any part of your place of business which is related to performance of the work. (d) Instructions Certification. When you submit data pursuant to subparagraph (a), you shall (1) do so in accordance with the instructions appearing in Table 15-2 of 48 C.F.R. Section 15.408 (2004) (adapted as necessary for the state context), and (2) submit a Certificate of Current Cost or Pricing Data, as prescribed by 48 CFR Section 15.406-2(a) (adapted as necessary for the state context). (e) Subcontracts. You shall include the above text of this clause in all of your subcontracts. (f) Nothing in this clause limits any other rights of the state.

PROTECTION OF HUMAN HEALTH AND THE ENVIRONMENT

The University of South Carolina requires that all contractual activities to be in compliance with local, state and federal mandates concerning "protection of human health and the environment". In addition, the University of South Carolina is a "Drug Free Work Place" and requires all contractors to comply with South Carolina Code of Laws Section 41-15-10 ET sequence (1976 w/amendments). Any contractor doing business with the University will be required to document compliance with these mandates and to furnish specific information requested by the University's Department of Environmental Health and Safety when notified to do so. The Contractor understands and agrees that jobsites are open at all times work is being performed by the Contractor to authorized University employees who have been trained to identify unsafe work conditions. The Contractor will immediately correct any deficiencies noted by these inspections when requested by the University's Department of Environmental Health and Safety to do so. In work areas where a specific hazard is posed which includes but is not limited to lead paint and asbestos abatement projects, Contractors will be required to produce Lead Compliance Plans and Asbestos Project Designs which outline their method of work prior to the start of work. Each contractor shall designate a responsible member of the Contractor's organization to be at the site whose duty shall be the prevention of accidents. By submission of this bid, the vendor agrees to take all necessary steps to insure compliance with the requirements outlined above.

RELATIONSHIP OF THE PARTIES (JAN 2006)

Neither party is an employee, agent, partner, or joint venturer of the other. Neither party has the right or ability to bind the other to any agreement with a third party or to incur any obligation or liability on behalf of the other party.

RESTRICTIONS ON PRESENTING TERMS OF USE OR OFFERING ADDITIONAL SERVICES (FEB 2015)

(a) Citizens, as well as public employees (acting in their individual capacity), should not be unnecessarily required to agree to or provide consent to policies or contractual terms in order to access services acquired by the government pursuant to this contract (hereinafter "applicable services") or, in the case of public employees, to perform their job duties; accordingly, in performing the work, contractor shall not require or invite any citizen or public employee to agree to or provide consent to any end user contract, privacy policy, or other terms of use (hereinafter "terms of use") not previously approved in writing by the procurement officer. Contractor agrees that any terms of use regarding applicable services are void and of no effect.

(b) Unless expressly provided in the solicitation, public contracts are not intended to provide contractors an opportunity to market additional products and services; accordingly, in performing the work, contractor shall not –

for itself or on behalf of any third party – offer citizens or public employees (other than the procurement officer) any additional products or services not required by the contract.

(c) Any reference to contractor in items (a) or (b) also includes any subcontractor at any tier. Contractor is responsible for compliance with these obligations by any person or entity that contractor authorizes to take any action related to the work.

(d) Any violation of this clause is a material breach of contract. The parties acknowledge the difficulties inherent in determining the damage from any breach of these restrictions. Contractor shall pay the state liquidated damages of \$1,000 for each contact with a citizen or end user that violates this restriction.

SHIPPING / RISK OF LOSS (JAN 2006)

F.O.B. Destination. Destination is the shipping dock of the Using Governmental Units' designated receiving site, or other location, as specified herein. (See Delivery clause)

STORAGE OF MATERIALS (JAN 2006)

Absent approval of the using governmental unit, Contractor shall not store items on the premises of the using governmental unit prior to the time set for installation.

SUBSTITUTIONS PROHIBITED - END PRODUCT PREFERENCES (SEP 2009)

If you receive the award as a result of the South Carolina end product or United States end product preference, you may not substitute a nonqualifying end product for a qualified end product. If you violate this provision, the State may terminate your contract for cause and you may be debarred. In addition, you shall pay to the State an amount equal to twice the difference between the price paid by the State and your evaluated price for the item for which you delivered a substitute.

SUBCONTRACTOR SUBSTITUTION PROHIBITED - RESIDENT SUBCONTRACTOR PREFERENCE (SEP 2009)

If you receive an award as a result of the subcontractor preference, you may not substitute any business for the subcontractor upon which you relied to qualify for the preference, unless first approved in writing by the procurement officer. If you violate this provision, the State may terminate your contract for cause and you may be debarred. In addition, the procurement officer may require you to pay the State an amount equal to twice the difference between the price paid by the State and the price offered by the next lowest bidder, unless the substituted subcontractor qualifies for the preference.

TERM OF CONTRACT – EFFECTIVE DATE / INITIAL CONTRACT PERIOD

The effective date of this contract is the first day of the Maximum Contract Period as specified on the final statement of award. The initial/maximum term of this agreement is 0 year, **4 months**, 0 days from the effective date. Regardless, this contract expires no later than the last date stated on the final statement of award.

TERMINATION FOR CONVENIENCE (JAN 2006)

(1) Termination. The Procurement Officer may terminate this contract in whole or in part, for the convenience of the State. The Procurement Officer shall give written notice of the termination to the contractor specifying the part of the contract terminated and when termination becomes effective.

(2) Contractor's Obligations. The contractor shall incur no further obligations in connection with the terminated work and on the date set in the notice of termination the contractor will stop work to the extent specified. The contractor shall also terminate outstanding orders and subcontracts as they relate to the terminated work. The contractor shall settle the liabilities and claims arising out of the termination of subcontracts and orders connected with the terminated work. The Procurement Officer may direct the contractor to assign the contractor's right, title, and interest under terminated orders or subcontracts to the State. The contractor must still complete the work not terminated by the notice of termination and may incur obligations as are necessary to do so.

(3) Right to Supplies. The Procurement Officer may require the contractor to transfer title and deliver to the State in the manner and to the extent directed by the Procurement Officer: (a) any completed supplies; and (b) such partially completed supplies and materials, parts, tools, dies, jigs, fixtures, plans, drawings, information, and contract rights (hereinafter called "manufacturing material") as the contractor has specifically produced or specially

acquired for the performance of the terminated part of this contract. The contractor shall, upon direction of the Procurement Officer, protect and preserve property in the possession of the contractor in which the State has an interest. If the Procurement Officer does not exercise this right, the contractor shall use best efforts to sell such supplies and manufacturing materials in a accordance with the standards of Uniform Commercial Code Section 2-706. Utilization of this Section in no way implies that the State has breached the contract by exercise of the Termination for Convenience Clause.

(4) Compensation. (a) The contractor shall submit a termination claim specifying the amounts due because of the termination for convenience together with cost or pricing data required by Section 11-35-1830 bearing on such claim. If the contractor fails to file a termination claim within one year from the effective date of termination, the Procurement Officer may pay the contractor, if at all, an amount set in accordance with Subparagraph (c) of this Paragraph.

(b) The Procurement Officer and the contractor may agree to a settlement and that the settlement does not exceed the total contract price plus settlement costs reduced by payments previously made by the State, the proceeds of any sales of supplies and manufacturing materials under Paragraph (3) of this clause, and the contract price of the work not terminated;

(c) Absent complete agreement under Subparagraph (b) of this Paragraph, the Procurement Officer shall pay the contractor the following amounts, provided payments agreed to under Subparagraph (b) shall not duplicate payments under this Subparagraph:

(i) contract prices for supplies or services accepted under the contract;

(ii) costs reasonably incurred in performing the terminated portion of the work less amounts paid or to be paid for accepted supplies or services;

(iii) reasonable costs of settling and paying claims arising out of the termination of subcontracts or orders pursuant to Paragraph (2) of this clause. These costs must not include costs paid in accordance with Subparagraph (c)(ii) of this paragraph;

(iv) any other reasonable costs that have resulted from the termination. The total sum to be paid the contractor under this Subparagraph shall not exceed the total contract price plus the reasonable settlement costs of the contractor reduced by the amount of payments otherwise made, the proceeds of any sales of supplies and manufacturing materials under Subparagraph (b) of this Paragraph, and the contract price of work not terminated.

(d) Contractor must demonstrate any costs claimed, agreed to, or established under Subparagraphs (b) and (c) of this Paragraph using its standard record keeping system, provided such system is consistent with any applicable Generally Accepted Accounting Principles.

(5) Contractor's failure to include an appropriate termination for convenience clause in any subcontract shall not (i) affect the state's right to require the termination of a subcontract, or (ii) increase the obligation of the state beyond what it would have been if the subcontract had contained an appropriate clause.

WARRANTY – STANDARD (JAN 2006)

Contractor must provide the manufacturer's standard written warranty upon delivery of product. Contractor warrants that manufacturer will honor the standard written warranty provided.

VIII. BIDDING SCHEDULE / PRICE-BUSINESS PROPOSAL

LOT A: ITEMS 1-3

Item	Qty	Unit of Measure	Description	Unit Price	Extended Price
1	1	EA	<u>Labor</u> to procure and install elevated running support structure, as stated herein.	\$	\$
2	1	EA	<u>Material</u> to procure and install elevated running support structure, as stated herein.	\$	\$
3	1	EA	Freight Charges	\$	\$
Total for Lot A (Items 1-3)					\$

IX. ATTACHMENTS TO SOLICITATION

ATTACHMENTS LIST

The following documents are attached to this solicitation:

IMPORTANT TAX NOTICE - NONRESIDENTS ONLY
OFFEROR'S CHECKLIST
ATTACHMENT A

IMPORTANT TAX NOTICE - NONRESIDENTS ONLY

Withholding Requirements for Payments to Nonresidents: Section 12-8-550 of the South Carolina Code of Laws requires

persons hiring or contracting with a nonresident conducting a business or performing personal services of a temporary nature within South Carolina to withhold 2% of each payment made to the nonresident. The withholding requirement does not apply to (1) payments on purchase orders for tangible personal property when the payments are not accompanied by services to be performed in South Carolina, (2) nonresidents who are not conducting business in South Carolina, (3) nonresidents for contracts that do not exceed \$10,000 in a calendar year, or (4) payments to a nonresident who (a) registers with either the S.C. Department of Revenue or the S.C. Secretary of State and (b) submits a Nonresident Taxpayer Registration Affidavit - Income Tax Withholding, Form I-312 to the person letting the contract.

The withholding requirement applies to every governmental entity that uses a contract ("Using Entity"). Nonresidents should submit a separate copy of the Nonresident Taxpayer Registration Affidavit - Income Tax Withholding, Form I-312 to every Using Entity that makes payment to the nonresident pursuant to this solicitation. Once submitted, an affidavit is valid for all contracts between the nonresident and the Using Entity, unless the Using Entity receives notice from the Department of Revenue that the exemption from withholding has been revoked.

Section 12-8-540 requires persons making payment to a nonresident taxpayer of rentals or royalties at a rate of \$1,200.00 or more a year for the use of or for the privilege of using property in South Carolina to withhold 7% of the total of each payment made to a nonresident taxpayer who is not a corporation and 5% if the payment is made to a corporation. Contact the Department of Revenue for any applicable exceptions.

For information about other withholding requirements (e.g., employee withholding), contact the Withholding Section at the South Carolina Department of Revenue at 803-898-5383 or visit the Department's website at: <https://dor.sc.gov>

This notice is for informational purposes only. This agency does not administer and has no authority over tax issues. All registration questions should be directed to the License and Registration Section at 803-898-5872 or to the South Carolina Department of Revenue, Registration Unit, Columbia, S.C. 29214-0140. All withholding questions should be directed to the Withholding Section at 803-896-1420.

PLEASE SEE THE "NONRESIDENT TAXPAYER REGISTRATION AFFIDAVIT INCOME TAX WITHHOLDING" FORM (FORM NUMBER I-312) LOCATED AT: https://dor.sc.gov/forms-site/Forms/I312_05182015.pdf

OFFEROR'S CHECKLIST -- AVOID COMMON BID/PROPOSAL MISTAKES

Review this checklist prior to submitting your bid/proposal.

If you fail to follow this checklist, you risk having your bid/proposal rejected.

- Do not include any of your standard contract forms!
- Unless expressly required, do not include any additional boilerplate contract clauses.
- Reread your entire bid/proposal to make sure your bid/proposal does not take exception to any of the state's mandatory requirements.
- Make sure you have properly marked all protected, confidential, or trade secret information in accordance with the instructions entitled: SUBMITTING CONFIDENTIAL INFORMATION. **DO NOT mark your entire bid/proposal as confidential, trade secret, or protected! Do not include a legend on the cover stating that your entire response is not to be released!**
- Have you properly acknowledged all amendments? Instructions regarding how to acknowledge an amendment should appear in all amendments issued.
- Make sure your bid/proposal includes a copy of the solicitation cover page. Make sure the cover page is signed by a person that is authorized to contractually bind your business.
- Make sure your Bid/proposal includes the number of copies requested.
- Check to ensure your Bid/proposal includes everything requested!
- If you have concerns about the solicitation, do not raise those concerns in your response! **After opening, it is too late! If this solicitation includes a pre-bid/proposal conference or a question & answer period, raise your questions as a part of that process!** Please see instructions under the heading "submission of questions" and any provisions regarding pre-bid/proposal conferences.

The University of South Carolina seeks to procure an elevated running support structure as defined by the criteria below:

- Structure to be constructed of plywood and steel and per the dimensions, requirements and details indicated in this solicitation document.
- Structure is to be engineered, designed, and manufactured by Mondo. Design drawings for the steel support structure are to be stamped and signed by a South Carolina Professional Engineer and should follow IBC 2012 where applicable. Design drawings are to be submitted for review and approval prior to start of fabrication. Structure is to be pre-fabricated to the greatest extent possible at the manufacturer's facility and then shipped and assembled on-site at 116 Marion Street, Columbia, SC 29205. Assembly personnel must be pre-approved by Mondo.
- Steel portion of support structure should conform to AISC manual of steel construction and all welded connections should conform to the latest revised code of the American Welding Society. Connections to be welded all around with the minimum applicable fillet or butt weld size and all structural shapes shall be made with 36 ksi structural steel. Steel structure should be designed for a dead load of 5 psf and a live load of 100 psf and be compliant with Seismic Design Category C.
- Plywood sheathing portion of support structure should be minimum thickness of $\frac{3}{4}$ inch plywood prepared to accept synthetic running surfacing material (not included in this solicitation). Plywood sheathing to be designed for a live load of 100 psf. Appropriate connection of plywood sheathing to steel support structure to be included in the overall design.
- Structure to include engineering, design, fabrication and assembly of guardrails and pads and their associated support structures as indicated on the drawings. Structure to include portable aluminum curb at interior perimeter as indicated on the drawings.
- Codes and standards for this structure to follow the current guidelines set forth by the International Association of Athletics Federations (IAAF) and the National Collegiate Athletic Association (NCAA).
- Incorrectly fabricated, damaged or assembled materials shall be replaced at the bidder's expense. Nonconforming materials or conditions shall be replaced and/or corrected at the bidder's expense.
- Structure is to be delivered and assembled complete no later than December 1, 2017.
- Bidders are to provide pricing broken down into material and on-site assembly labor categories so that tax can be calculated on material only. Freight to be included.
- Bidders are allowed to invoice for monthly progress payments.

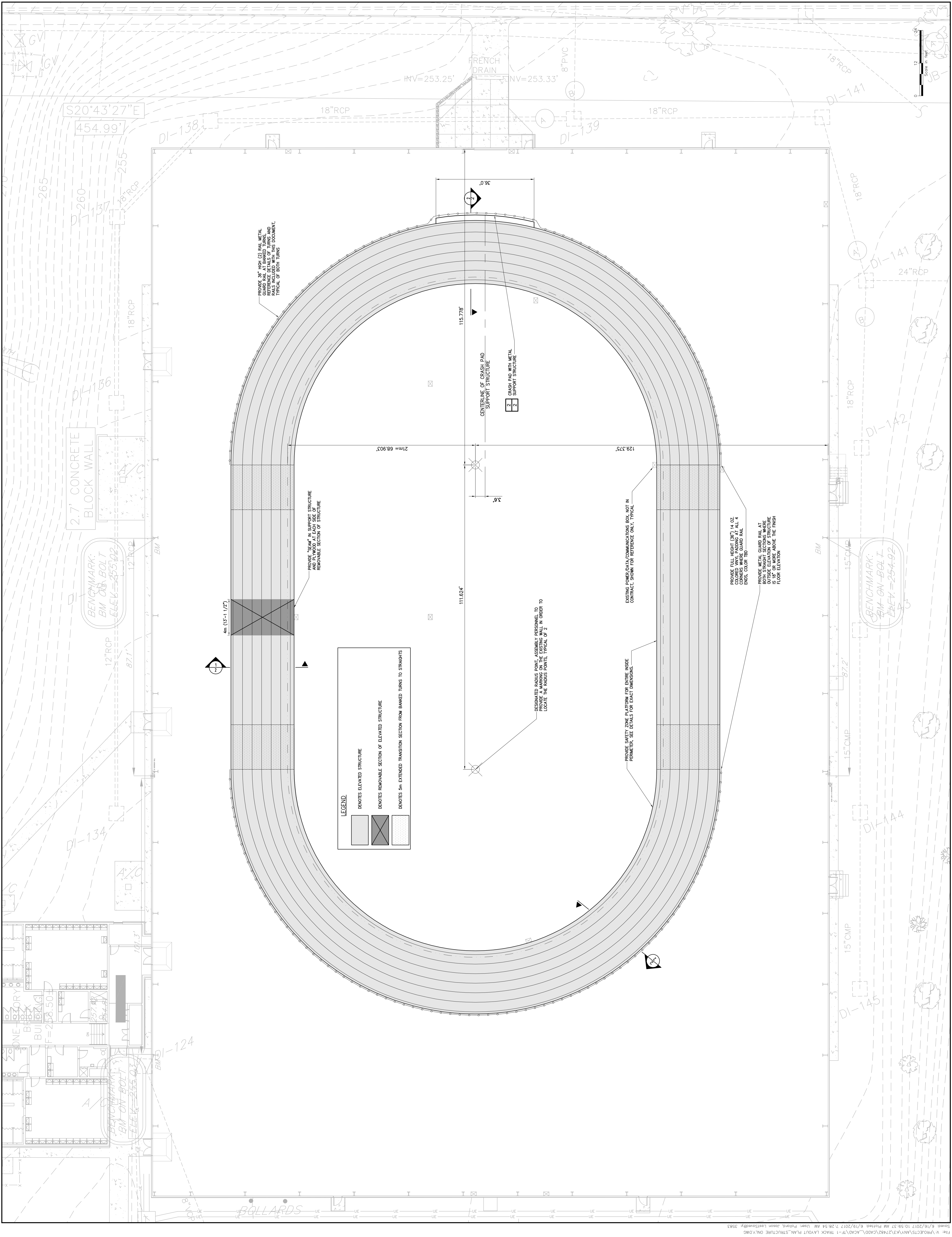

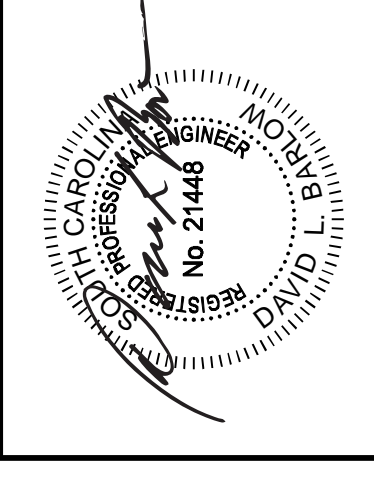
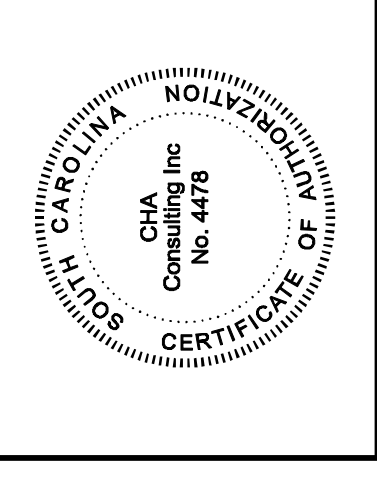
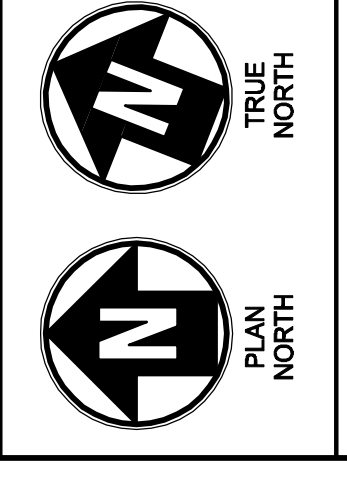

116 MARION STREET
 COLUMBIA, S.C. 29208

No.	Submitted / Revision	App'd. By	Date
DETAILS			
ISSUED FOR NO.	T08	JRP	06/01/17
Designed By:	JRP	Checked By:	EJD
Issue Date:	06-16-17	Project No.:	27482
		Scale:	AS SHOWN
			Drawing No.:
			2

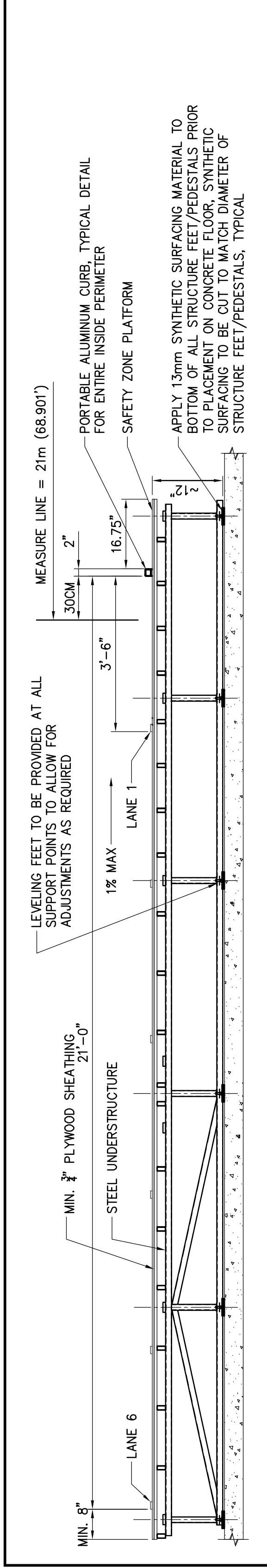

1 TYPICAL SECTION AT STRAIGHTS
 SCALE: 1/2"=1'-0"

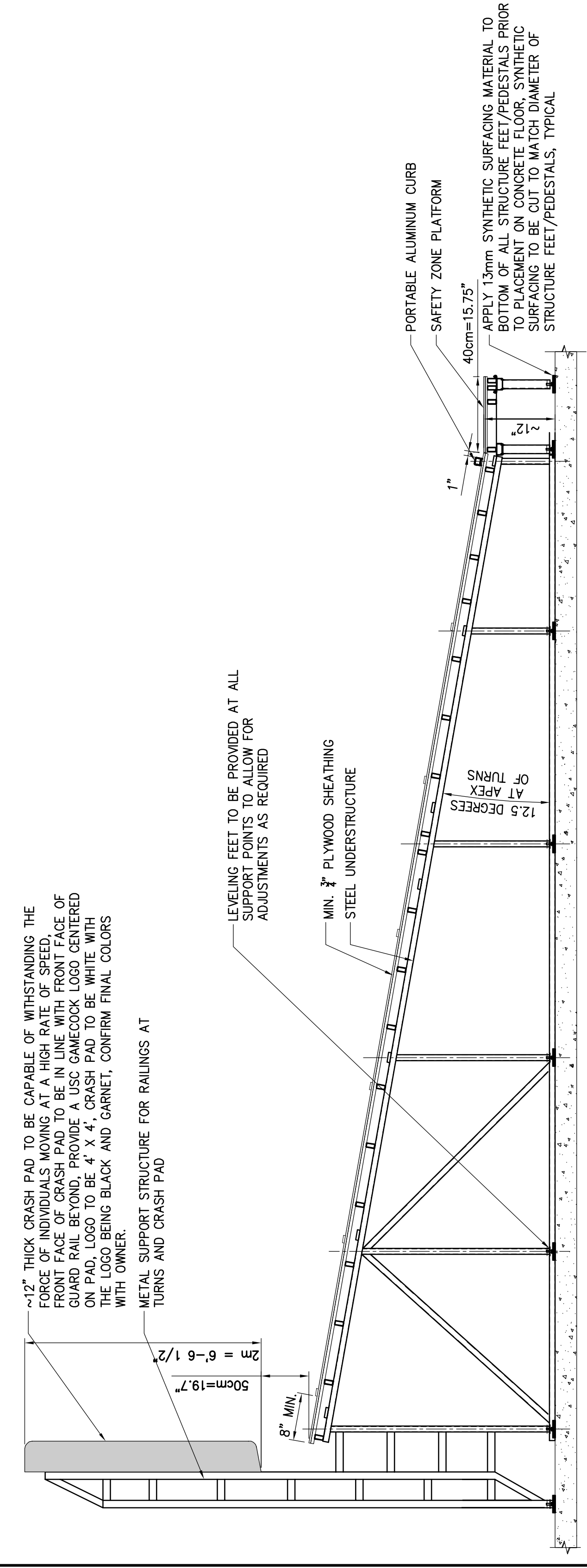

BANKED SECTION AT CRASH PAD

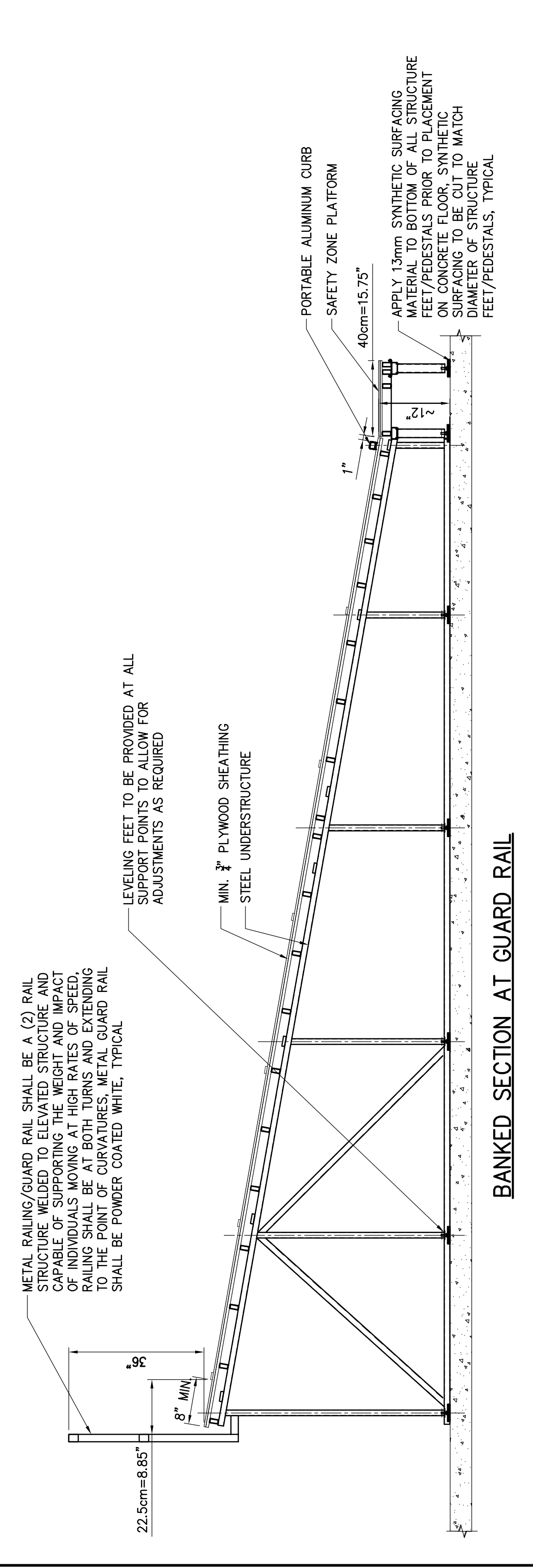

BANKED SECTION AT GUARD RAIL

2 TYPICAL SECTION AT BANKED TURNS
 SCALE: 1/2"=1'-0"