



UNIVERSITY OF
SOUTH CAROLINA

Project Manual
USC McKissick Plaza Improvements

Project # H27-Z327

June 1, 2017

USC Facilities Design & Construction

743 Greene Street

Columbia, SC 29208

Table of Contents

Project Number: H27-Z327

Project Name: McKissick Plaza Improvements

Section 1	Number of Pages
<hr/>	
Table of Contents	1
Invitation for Minor Construction Quotes (SE311, 2016 Edition)	1
Standard Bid Quote (SE331, 2016 Edition)	1
Instructions to Bidders	3
USC Supplemental General Conditions for Construction Projects	5
Standard Details for Silt Fence & Inlet Protection	6
Contractor’s One-Year Guarantee	1
Section 2-Technical Specifications	
31 20 00 Earthwork.....	7
32 14 00 Unit Paving.....	6
32 84 00 Underground Irrigation.....	7

SE-311

INVITATION FOR MINOR CONSTRUCTION QUOTES

PROJECT NAME: McKissick Plaza ImprovementsPROJECT NUMBER: H27-Z327PROJECT LOCATION: McKissick Museum & Visitors Center, USC Campus @ Bull and Pendleton Streets, ColumbiaBID SECURITY REQUIRED? Yes No PERFORMANCE BOND REQUIRED? Yes No PAYMENT BOND REQUIRED? Yes No CONSTRUCTION COST RANGE: \$ 20,000 - \$45,000DESCRIPTION OF PROJECT: Replace and repair brick walkways; improve drainage; add irrigation system; Small and minority business participation is encouraged.BIDDING DOCUMENTS/PLANS MAY BE OBTAINED FROM: purchasing.sc.edu, Facilities/Construction Solicitations & AwardsPLAN DEPOSIT AMOUNT: \$ \$0.00 IS DEPOSIT REFUNDABLE Yes No N/A

Bidders must obtain Bidding Documents/Plans from the above listed source(s) to be listed as an official plan holder. Only those Bidding Documents/Plans obtained from the above listed source(s) are official. Bidders rely on copies of Bidding Documents/Plans obtained from any other source at their own risk.

IN ADDITION TO THE ABOVE OFFICIAL SOURCE(S), BIDDING DOCUMENTS/PLANS ARE ALSO AVAILABLE AT:

It is the contractor's responsibility to check the purchasing website for all plans, addenda, and awards: http://purchasing.sc.edu

All questions & correspondence concerning this Invitation shall be addressed to the A/E.

A/E NAME: Emily JonesA/E CONTACT: University of South CarolinaA/E ADDRESS: Street/PO Box: 783 Greene StCity: ColumbiaState: SCZIP: 29208-EMAIL: efjones@fmc.sc.eduTELEPHONE: 803-777-7592

FAX: _____

AGENCY: University of South CarolinaAGENCY PROJECT COORDINATOR: Aimee RishADDRESS: Street/PO Box: 743 Greene StCity: ColumbiaState: SCZIP: 29208-EMAIL: arish@fmc.sc.eduTELEPHONE: 803-777-2261

FAX: _____

PRE-QUOTE CONFERENCE: Yes No MANDATORY ATTENDANCE: Yes No PRE-QUOTE DATE: 6/29/2017 TIME: 11:00 amPLACE: Conf. Rm. 57, 743 Greene St, Columbia, SC 29208QUOTE CLOSING DATE: 7/11/2017 TIME: 2:00 pmPLACE: Conf. Rm. 57, 743 Greene St, Columbia, SC 29208

QUOTE DELIVERY ADDRESSES:

HAND-DELIVERY:

Attn: Aimee Rish USC Facilities Center743 Greene StreetColumbia, SC 29208

MAIL SERVICE:

Attn: Aimee Rish USC Facilities Center743 Greene StreetColumbia, SC 29208

APPROVED BY: _____

(Agency Project Coordinator)

DATE: _____

Instructions to Bidders

1. Bidding Documents include the Bidding Requirements and the proposed Contract Documents. The Bidding Requirements consist of the Advertisement or Invitation to Bid, Instructions to Bidders, Supplementary Instructions to Bidders, the bid form, and other sample bidding and contract forms. The Drawings, Specifications and all Addenda issued prior to execution of the Purchase Order.
2. Addenda are written or graphic instruments issued by the Architect prior to the execution of the Contract which modify or interpret the Bidding Documents by additions, deletions, clarifications or corrections.
3. A Bid is a complete and properly executed proposal to do the Work for the sums stipulated therein, submitted in accordance with the Bidding Documents.
4. The Base Bid is the sum stated in the Bid for which the Bidder offers to perform the Work described in the Bidding Documents as the base, to which Work may be added or from which Work may be deleted for sums stated in Alternate Bids.
5. An Alternate Bid (or Alternate) is an amount stated in the Bid to be added to or deducted from the amount of the Base Bid if the corresponding change in the Work, as described in the Bidding Documents, is accepted.
6. A Bidder is a person or entity who submits a Bid and who meets the requirements set forth in the Bidding Documents.
7. The Bidder by making a Bid represents that the Bidder has read and understands the Bidding Documents, to the extent that such documentation relates to the Work for which the Bid is submitted, and for other portions of the Project, if any, being bid concurrently or presently under construction.
8. The Bid is made in compliance with the Bidding Documents.
9. The Bidder has visited the site, become familiar with local conditions under which the Work is to be performed and has correlated the Bidder's personal observations with the requirements of the proposed Contract Documents.
10. The Bid is based upon the materials, equipment and systems required by the Bidding Documents without exception.
11. Bidders shall use complete sets of Bidding Documents in preparing Bids; neither the Owner nor Architect assumes responsibility for errors or misinterpretations resulting from the use of incomplete sets of Bidding Documents.
12. Bidders and Sub-bidders requiring clarification or interpretation of the Bidding Documents shall make a written request which shall reach the Architect at least seven days prior to the date for receipt of Bids.

13. Interpretations, corrections and changes of the Bidding Documents will be made by Addendum. Interpretations, corrections and changes of the Bidding Documents made in any other manner will not be binding, and Bidders shall not rely upon them.
14. The materials, products and equipment described in the Bidding Documents establish a standard of required function, dimension, appearance and quality to be met by any proposed substitution.
15. No substitution will be considered prior to receipt of Bids unless written request for approval has been received by the Architect at least ten days prior to the date for receipt of Bids. Such requests shall include the name of the material or equipment for which it is to be substituted and a complete description of the proposed substitution including drawings, performance and test data, and other information necessary for an evaluation. A statement setting forth changes in other materials, equipment or other portions of the Work, including changes in the work of other contracts that incorporation of the proposed substitution would require, shall be included. The burden of proof of the merit of the proposed substitution is upon the proposer. The Architect's decision of approval or disapproval of a proposed substitution shall be final.
16. If the Architect approves a proposed substitution prior to receipt of Bids, such approval will be set forth in an Addendum. Bidders shall not rely upon approvals made in any other manner.
17. No substitutions will be considered after the Contract award unless specifically provided for in the Contract Documents.
18. Addenda will be issued no later than five days prior to the date for receipt of Bids except an Addendum withdrawing the request for Bids or one which includes postponement of the date for receipt of Bids.
19. Each Bidder shall ascertain prior to submitting a Bid that the Bidder has received all Addenda issued, and the Bidder shall acknowledge their receipt in the Bid.
20. Bids shall be submitted on the forms included with the Bidding Documents.
21. All blanks on the bid form shall be legibly executed in a non-erasable medium.
22. Sums shall be expressed in both words and figures. In case of discrepancy, the amount written in words shall govern.
23. Interlineations, alterations and erasures must be initialed by the signer of the Bid.
24. All requested Alternates shall be bid. If no change in the Base Bid is required, enter "No Change."
25. All copies of the Bid, the bid security, if any, and any other documents required to be submitted with the Bid shall be enclosed in a sealed opaque envelope. The envelope shall be addressed to the party receiving the Bids and shall be identified with the Project name, the Bidder's name and address and, if applicable, the designated portion of the Work for which the Bid is submitted. If the Bid is sent by mail, the sealed envelope shall be enclosed in a separate mailing envelope with the notation "SEALED BID ENCLOSED" on the face thereof.
26. Bids shall be deposited at the designated location prior to the time and date for receipt of Bids. Bids received after the time and date for receipt of Bids will be returned unopened.

27. The Bidder shall assume full responsibility for timely delivery at the location designated for receipt of Bids.
28. The Owner shall have the right to reject any or all Bids. A Bid not accompanied by a required bid security or by other data required by the Bidding Documents, or a Bid which is in any way incomplete or irregular is subject to rejection.
29. It is the intent of the Owner to award a Contract to the lowest qualified Bidder provided the Bid has been submitted in accordance with the requirements of the Bidding Documents and does not exceed the funds available. The Owner shall have the right to waive informalities and irregularities in a Bid received and to accept the Bid which, in the Owner's judgment, is in the Owner's own best interests.
30. The Owner shall have the right to accept Alternates in any order or combination, unless otherwise specifically provided in the Bidding Documents, and to determine the low Bidder on the basis of the sum of the Base Bid and Alternates accepted.

**SE-331
QUOTE FORM**

Quotes shall be submitted only on SE-331.

QUOTE SUBMITTED BY: _____
(Offeror's Name)

QUOTE SUBMITTED TO: _____
(Owner's Name)

FOR: PROJECT NAME: McKissick Plaza Improvements
PROJECT NUMBER: H27-Z327

OFFER

1. In response to the Invitation for Minor Construction Quotes, and in compliance with the Instructions to Bidders for the above-named Project, the undersigned **OFFEROR** proposes and agrees, if this Quote is accepted, to enter into a Contract with the Owner in the form included in the Solicitation Documents, and to perform all Work as specified or indicated in the Solicitation Documents, for the prices and within the time frames indicated in the Solicitation and in accordance with the other terms and conditions stated.
2. Pursuant to Section 11-35-3030(1) of the SC Code of Laws, as amended, **OFFEROR** has submitted Bid Security as follows in the amount and form required by the Solicitation Documents:

- Bid Bond with Power of Attorney Electronic Bid Bond Cashier's Check

(Bidder check one)

3. **OFFEROR** acknowledges the receipt of the following Addenda to the Solicitation documents and has incorporated the effects of said Addenda into its Quote (Bidder, check only boxes that apply.):

ADDENDA: #1 #2 #3 #4 #5

4. **OFFEROR** agrees that this Quote, including all bid alternates, if any, may not be revoked or withdrawn after the opening of quotes, and shall remain open for acceptance for a period of **60** Days following the Quote Date, or for such longer period of time that **OFFEROR** may agree to in writing upon request of the Owner.
5. **OFFEROR** agrees that from the compensation to be paid, the Owner shall retain as Liquidated Damages the amount of \$ **100.00** for each calendar day the actual construction time required to achieve Substantial Completion exceeds the specified or adjusted Contract Time for Substantial Completion, as provided in the Contract Documents.
6. **OFFEROR** herewith submits its offer to provide all labor, materials, equipment, tools of trades and labor, accessories, appliances, warranties and guarantees, and to pay all royalties, fee, permits, licenses and applicable taxes necessary to complete the following items of construction work:

6.1 BASE QUOTE \$ _____
(enter BASE QUOTE in figures only)

6.1.1 ALTERNATE NO. 1 \$ _____ to be **ADDED / DEDUCTED** from BASE QUOTE.
(circle one)

6.1.2 ALTERNATE NO. 2 \$ _____ to be **ADDED / DEDUCTED** from BASE QUOTE.
(circle one)

SC Contractor's License Number: _____

Classification(s) & Limits: _____

Address: _____

Telephone/Fax: _____

E-mail: _____

This Quote is hereby submitted on behalf of the Offeror named above.

BY: _____
(Signature of Offeror's Representative)

(Print or Type Name of Offeror's Representative)

TITLE: _____

USC SUPPLEMENTAL GENERAL CONDITIONS FOR CONSTRUCTION PROJECTS

WORK AREAS

1. The Contractor shall maintain the job site in a safe manner at all times. This includes (but is not limited to) the provision and/or maintenance of lighting, fencing, barricades around obstructions, and safety and directional signage.
2. Contractor's employees shall take all reasonable means not to interrupt the flow of student traffic in building corridors, lobbies, stairs and exterior walks. All necessary and reasonable safety precautions shall be taken to prevent injury to building occupants while transporting materials and equipment through the work area. Providing safe, accessible, plywood-shielded pedestrian ways around construction may be required if a suitable alternative route is not available.
3. At the beginning of the project, the USC Project Manager will establish the Contractor's lay-down area. This area will also be used for the Contractor's work vehicles. The lay-down area will be clearly identified to the contractor by the Project Manager, with a sketch or drawing provided to USC Parking Services. In turn, Parking Services will mark off this area with a sign containing the project name, Project Manager's name, Contractor name and contact number, and end date. Where this area is subject to foot traffic, protective barriers will be provided as specified by the Project Manager. The area will be maintained in a neat and orderly fashion.
4. Work vehicles parked in the lay down area (or designated parking areas) will be clearly marked and display a USC-furnished placard for identification. No personal vehicles will be allowed in this area, or in any areas surrounding the construction site. Personal vehicles must be parked in the perimeter parking lots or garages. Temporary parking permits can be obtained at the Contractor's expense at the USC Parking Office located in the Pendleton Street parking garage. Refer to the CAMPUS VEHICLE EXPECTATIONS (below) for additional information.
5. Contractor is responsible for removal of all debris from the site, and is required to provide the necessary dumpsters which will be emptied on a regular basis. Construction waste must not be placed in University dumpsters. The construction site must be thoroughly cleaned with all trash picked up and properly disposed of on a daily basis and the site must be left in a safe and sanitary condition each day. The University will inspect job sites regularly and will fine any contractor found to be in violation of this requirement an amount of up to \$1,000 per violation.
6. The Contractor shall be responsible for erosion and sediment control measures where ground disturbances are made.

PROJECT FENCING

7. All construction projects with exterior impacts shall have construction fencing at the perimeter. Fencing shall be 6' chain link with black or green privacy fabric (80-90% blockage). For fence panels with footed stands, sandbag weights shall be placed on the inside of the fence. Ripped sandbags shall be replaced immediately.
8. For projects with long fencing runs and/or high profile locations, decorative USC banners shall be used on top of privacy fabric; banners should be used at a ratio of one banner for every five fence panels. USC Project Manager will make arrangements for banner delivery for Contractor to hang.
9. The use of plastic safety fencing is discouraged and shall only be used on a temporary basis (less than four weeks) where absolutely necessary. Safety fencing shall be a neon yellow-green, high-

visibility fencing equal to 'Kryptonight' by Tenax. Safety fencing shall be erected and maintained in a neat and orderly fashion throughout the project.

10. Vehicles and all other equipment shall be contained within a fenced area if they are on site for more than 3 consecutive calendar days.

BEHAVIOR

11. Fraternalization between Contractor's employees and USC students, faculty or staff is strictly prohibited.
12. USC will not tolerate rude, abusive or degrading behavior on the job site. Heckling and cat-calling directed toward students, faculty or staff or any other person on USC property is strictly prohibited. Any contractor whose employees violate this requirement will be assessed a fine of up to \$500 per violation.
13. Contractor's employees must adhere to the University's policy of maintaining a drug-free and tobacco-free campus.

HAZARDOUS MATERIALS & SAFETY COMPLIANCE

14. A USC Permit to Work must be signed prior to any work being performed by the general contractor or sub-contractor(s).
15. The contractor will comply with all regulations set forth by OSHA and SCDHEC. Contractor must also adhere to USC's internal policies and procedures (available by request). Upon request, the contractor will submit all Safety Programs and Certificates of Insurance to the University for review.
16. Contractor must notify the University immediately upon the discovery of suspect material which may contain asbestos or other such hazardous materials. These materials must not be disturbed until approved by the USC Project Manager.
17. In the event of an OSHA inspection, the Contractor shall immediately call the Facilities Call Center, 803-777-4217, and report that an OSHA inspector is on site. An employee from USC's Safety Unit will arrive to assist in the inspection.

LANDSCAPE & TREE PROTECTION

18. In conjunction with the construction documents, the USC Arborist shall direct methods to minimize damage to campus trees. Tree protection fencing is required to protect existing trees and other landscape features to be affected by a construction project. The location of this fence will be evaluated for each situation with the USC Arborist, Landscape Architect and Project Manager. Tree protection fencing may be required along access routes as well as within the project area itself. Fence locations may have to be reset throughout the course of the project.
19. The tree protection fence shall be 6' high chain link fence with 80-90% privacy screening unless otherwise approved by USC Arborist and/or Landscape Architect. If the tree protection fence is completely within a screened jobsite fence perimeter, privacy fabric is not required. In-ground fence posts are preferred in most situations for greater protection. If utility or pavement conflicts are present, fence panels in footed stands are acceptable. See attached detail for typical tree protection fencing.
20. No entry, vehicle parking, or materials storage will be allowed inside the tree protection zone. A 4"

layer of mulch shall be placed over the tree protection area to maintain moisture in the root zone.

21. Where it is necessary to cross walks, tree root zones (i.e., under canopy) or lawns the following protective measures shall be taken:
 - a. For single loads up to 9,000 lbs., a 3/4" minimum plywood base shall be placed over 4" of mulch.
 - b. For single loads over 9,000 lbs., two layers of 3/4" plywood shall be placed over 4" of mulch.
 - c. Plywood sheets shall be replaced as they deteriorate or delaminate with exposure.
 - d. For projects requiring heavier loads, a construction entry road consisting of 10' X 16' oak logging mats on 12" coarse, chipped, hardwood base. Mulch and logging mats shall be supplemented throughout the project to keep matting structurally functional.
22. Damage to any trees during construction shall be assessed by the USC Arborist, who will stipulate what action will be taken for remediation of damage. The cost of any and all remediation will be assumed by the contractor at no additional cost to the project. Compensation for damages may be assessed up to \$500 per caliper inch of tree (up to 8") and \$500 per inch of diameter at breast height (for trees over 8").
23. Damage to trunks and limbs, as well as disturbance of the root zone under the dripline of tree, including compaction of soil, cutting or filling, or storage of materials, shall qualify as damage and subject to remediation.
24. Any damage to existing pavements or landscaping (including lawn areas and irrigation) will be remediated before final payment is made.

TEMPORARY FACILITIES

25. Contractor will be responsible for providing its own temporary toilet facilities, unless prior arrangements are made with the USC Project Manager.
26. Use of USC communications facilities (telephones, computers, etc.) by the Contractor is prohibited, unless prior arrangements are made with the USC Project Manager.

CAMPUS KEYS

27. Contractor must sign a Contractor Key Receipt/Return form before any keys are issued. Keys must be returned immediately upon the completion of the work. The Contractor will bear the cost of any re-keying necessary due to the loss of or failure to return keys.

WELDING

28. A welding (hot work) permit must be issued by the University Fire Marshall before any welding can begin inside a building. The USC Project Manager will coordinate.

PROJECT EVALUATION & CLOSE-OUT

29. For all projects over \$100,000, including IDCs, a Contractor Performance Evaluation (SE 397) will be reviewed with the GC at the beginning of the project and a copy given to the GC. At the end of the project the form will be completed by the USC Project Manager and a Construction Performance rating will be established.
30. Contractor must provide all O&M manuals, as-built drawings, and training of USC personnel on new equipment, controls, etc. prior to Substantial Completion. Final payment will not be made until

this is completed.

CAMPUS VEHICLE EXPECTATIONS

31. Personal vehicles must be parked in the perimeter parking lots or garages. Temporary parking permits can be obtained at the Contractor's expense at the USC Parking Office located in the Pendleton Street parking garage.
32. All motorized vehicle traffic on USC walkways and landscape areas must be approved by the USC Project Manager and Parking Division, have a USC parking placard, and be parked within the approved laydown area. Violators may be subject to ticketing, towing and fines.
33. All motorized vehicles that leak or drip liquids are prohibited from traveling or parking on walks or landscaped areas.
34. Drivers of equipment or motor vehicles that damage university hardscape or landscape will be held responsible for damages and restoration expense.
35. All vehicles parked on landscape, hardscape, or in the process of service delivery, must display adequate safety devices, i.e. flashing lights, cones, signage, etc.
36. All drivers of equipment and vehicles shall be respectful of University landscape, equipment, structures, fixtures and signage.
37. All incidents of property damage shall be reported to Parking Services or the Work Management Center.

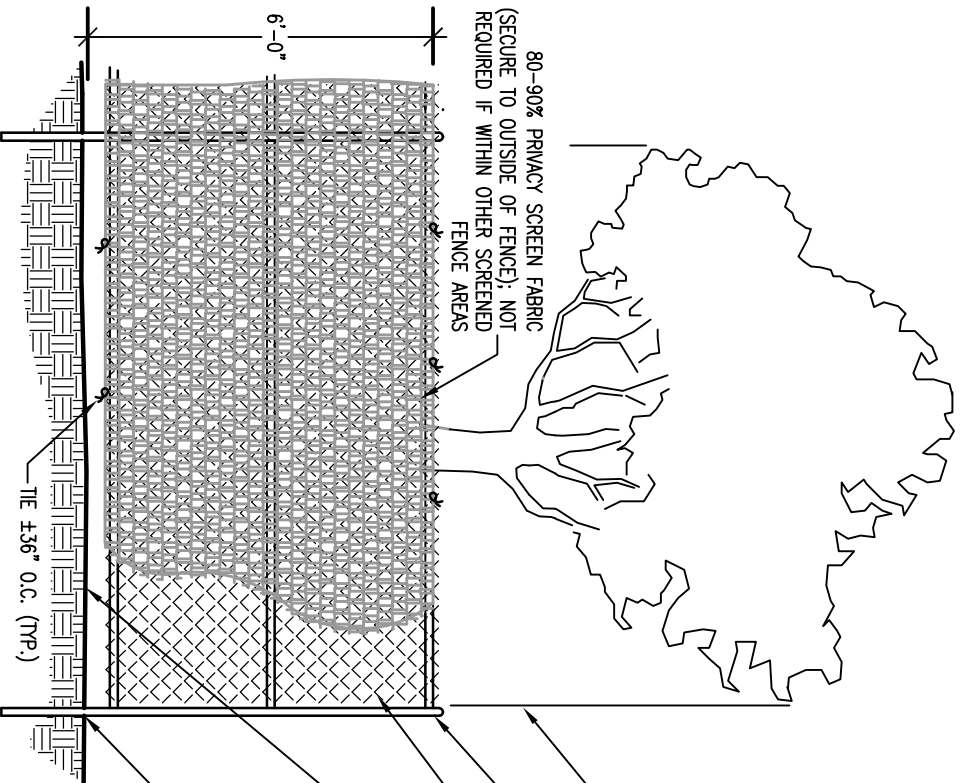

TREE PROTECTION FENCING (IN-GROUND) WITH SCREENING

NOTES:

1. PROVIDE PROTECTION FENCING FOR ALL TREES WITHIN AREA OF DISTURBANCE AND CONSTRUCTION ACCESS.
2. PROTECTION FENCING SHALL BE IN PLACE PRIOR TO BEGINNING CONSTRUCTION.
3. PROTECTION FENCING TO BE PLACED AT THE OUTSIDE OF THE CANOPY DRIPLINE, OR AT A DISTANCE OF ONE FOOT PER ONE INCH OF TREE DIAMETER, MEASURED AT BREAST HEIGHT, WHICHEVER IS LARGER, UNLESS OTHERWISE INDICATED ON LANDSCAPE PLAN OR APPROVED BY UNIVERSITY ARBORIST.
4. IN-GROUND POSTS ARE STANDARD. IF EXISTING ROOTS, UTILITIES OR PAVEMENT PRECLUDE USE OF IN-GROUND POSTS, FOOTED STANDS ARE ACCEPTABLE. SAND BAGS SHALL BE PLACED ON THE INSIDE OF FENCE.
5. DAMAGE TO ANY TREES DURING CONSTRUCTION SHALL BE ASSESSED BY UNIVERSITY ARBORIST AND THE UNIVERSITY ARBORIST SHALL STIPULATE WHAT ACTION WILL BE TAKEN FOR REMEDIATION OF DAMAGE. THE COST OF ANY AND ALL REMEDIATION WILL BE ASSUMED BY CONTRACTOR AT NO ADDITIONAL COST TO THE PROJECT.
6. DISTURBANCE OF ROOT ZONE UNDER DRIPLINE OF TREE, INCLUDING COMPACTION OF SOIL, CUTTING OR FILLING OR STORAGE OF MATERIALS SHALL QUALIFY AS DAMAGE AND SUBJECT TO REMEDIATION.

SILT FENCE INSTALLATION

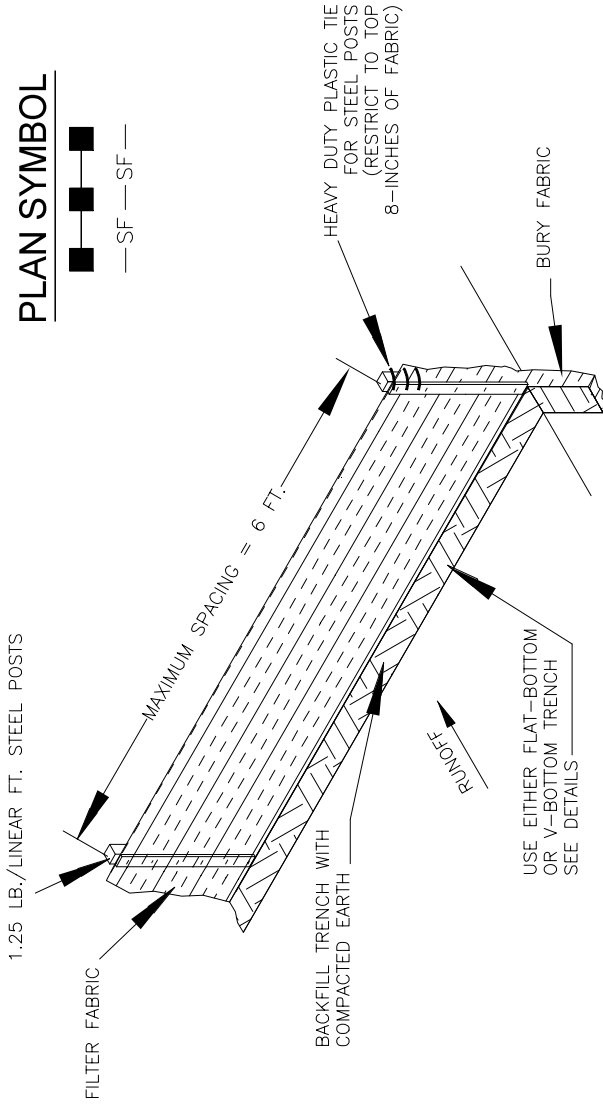

PLAN SYMBOL

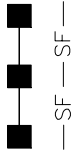

FLAT-BOTTOM TRENCH DETAIL

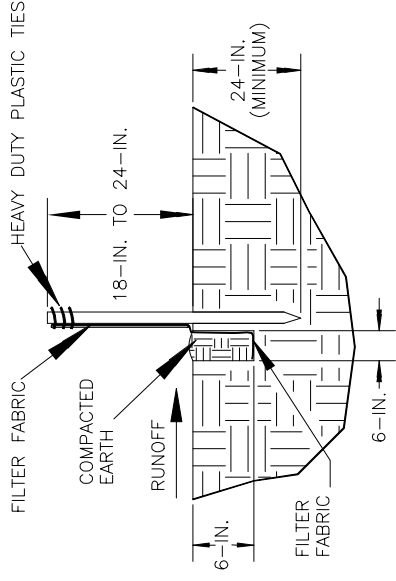

V-SHAPED TRENCH DETAIL

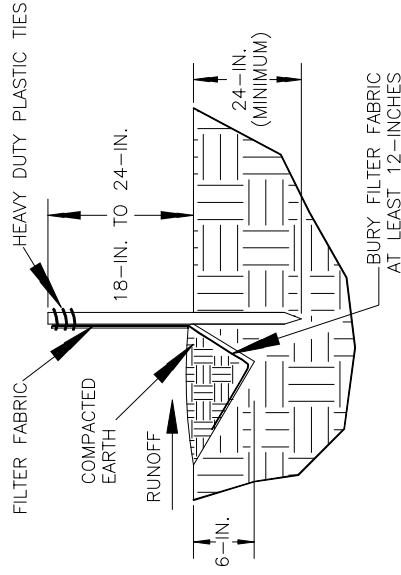

SILT FENCE — GENERAL NOTES

- Do not place silt fence across channels or in other areas subject to concentrated flows. Silt fence should not be used as a velocity control BMP. Concentrated flows are any flows greater than 0.5 cfs.
- Maximum sheet or overland flow path length to the silt fence shall be 100-feet.
- Maximum slope steepness (normal [perpendicular] to the fence line) shall be 2:1.
- Silt fence joints, when necessary, shall be completed by one of the following options:
 - Wrap each fabric together at a support post with both ends fastened to the post, with a 1-foot minimum overlap;
 - Overlap silt fence by installing 3-feet passed the support post to which the new silt fence roll is attached. Attach old roll to new roll with heavy-duty plastic ties; or,
 - Overlap entire width of each silt fence roll from one support post to the next support post.
- Attach filter fabric to the steel posts using heavy-duty plastic ties that are evenly spaced within the top 8-inches of the fabric.
- Install the silt fence perpendicular to the direction of the stormwater flow and place the silt fence the proper distance from the toe of steep slopes to provide sediment storage and access for maintenance and cleanout.
- Install Silt Fence Checks (Tie-Backs) every 50-100 feet, dependent on slope, along silt fence that is installed with slope and where concentrated flows are expected or are documented along the proposed/installed silt fence.

South Carolina Department of Health and Environmental Control

SILT FENCE

STANDARD DRAWING NO. SC-03 Page 1 of 2

NOT TO SCALE

FEBRUARY 2014
DATE

SILT FENCE — POST REQUIREMENTS

1. Silt fence posts must be 48-inch long steel posts that meet, at a minimum, the following physical characteristics.
 - Composed of a high strength steel with a minimum yield strength of 50,000 psi.
 - Include a standard "T" section with a nominal face width of 1.38-inches and a nominal "T" length of 1.48-inches.
 - Weigh 1.25 pounds per foot (\pm 8%)
2. Posts shall be equipped with projections to aid in fastening of filter fabric.
3. Steel posts may need to have a metal soil stabilization plate welded near the bottom when installed along steep slopes or installed in loose soils. The plate should have a minimum cross section of 17-square inches and be composed of 15 gauge steel, at a minimum. The metal soil stabilization plate should be completely buried.
4. Install posts to a minimum of 24-inches. A minimum height of 1- to 2-inches above the fabric shall be maintained, and a maximum height of 3 feet shall be maintained above the ground.
5. Post spacing shall be at a maximum of 6-feet on center.

SILT FENCE — FABRIC REQUIREMENTS

1. Silt fence must be composed of woven geotextile filter fabric that consists of the following requirements:
 - Composed of fibers consisting of long chain synthetic polymers of at least 85% by weight of polyolefins, polyesters, or polyamides that are formed into a network such that the filaments or yarns retain dimensional stability relative to each other;
 - Free of any treatment or coating which might adversely alter its physical properties after installation;
 - Free of any defects or flaws that significantly affect its physical and/or filtering properties; and,
 - Have a minimum width of 36-inches.
2. Use only fabric appearing on SC DOT's Qualified Products Listing (QPL), Approval Sheet #34, meeting the requirements of the most current edition of the SC DOT Standard Specifications for Highway Construction.
3. 12-inches of the fabric should be placed within excavated trench and toed in when the trench is backfilled.
4. Filter Fabric shall be purchased in continuous rolls and cut to the length of the barrier to avoid joints.
5. Filter Fabric shall be installed at a minimum of 24-inches above the ground.

SILT FENCE — INSPECTION & MAINTENANCE

1. The key to functional silt fence is weekly inspections, routine maintenance, and regular sediment removal.
2. Regular inspections of silt fence shall be conducted once every calendar week and, as recommended, within 24-hours after each rainfall even that produces 1/2-inch or more of precipitation.
3. Attention to sediment accumulations along the silt fence is extremely important. Accumulated sediment should be continually monitored and removed when necessary.
4. Remove accumulated sediment when it reaches 1/3 the height of the silt fence.
5. Removed sediment shall be placed in stockpile storage areas or spread thinly across disturbed area. Stabilize the removed sediment after it is relocated.
6. Check for areas where stormwater runoff has eroded a channel beneath the silt fence, or where the fence has sagged or collapsed due to runoff overtopping the silt fence. Install checks/tie-backs and/or reinstall silt fence, as necessary.
7. Check for tears within the silt fence, areas where silt fence has begun to decompose, and for any other circumstance that may render the silt fence ineffective. Removed damaged silt fence and reinstall new silt fence immediately.
8. Silt fence should be removed within 30 days after final stabilization is achieved and once it is removed, the resulting disturbed area shall be permanently stabilized.

1.25 LB./LINEAR FT.
STEEL POSTS

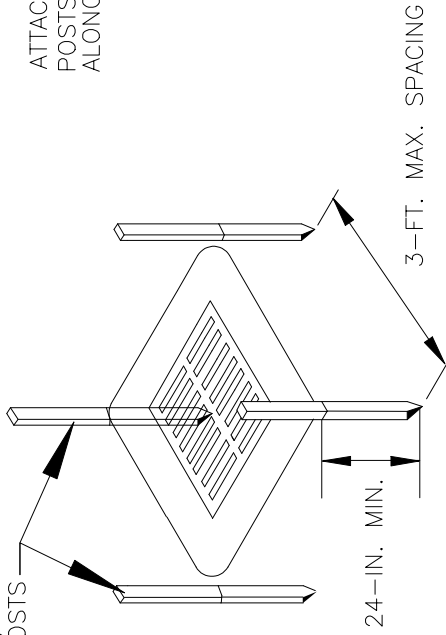

ATTACH FILTER FABRIC TO
POSTS WITH HEAVY DUTY PLASTIC TIES
ALONG TOP 8-INCHES OF FABRIC.

FOLD FABRIC TO OVERLAP
1 FOOT AND SECURE
TO POSTS WITH HEAVY DUTY
PLASTIC TIES

POST INSTALLATION DETAIL

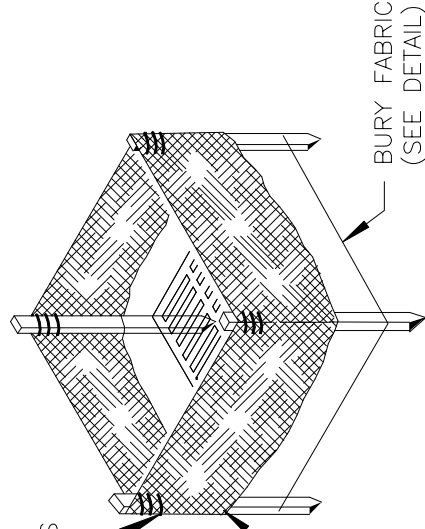

3-FT. MAX. SPACING

24-IN. MIN.

BURY FABRIC
(SEE DETAIL)

FILTER FABRIC INSTALLATION DETAIL

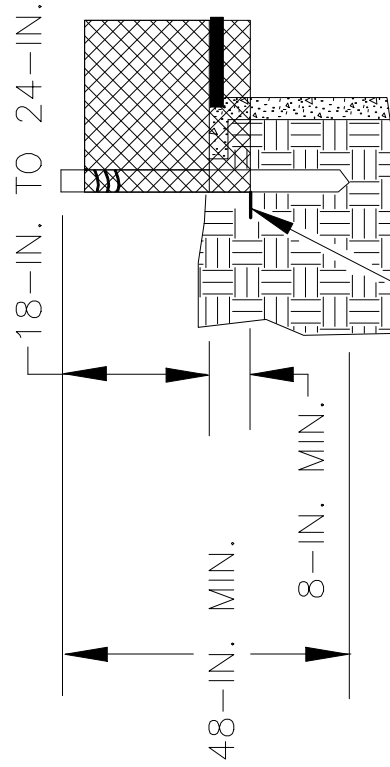

18-IN. TO 24-IN.

48-IN. MIN.

8-IN. MIN.

BURY & TRENCH MINIMUM
OF 12-INCHES OF FILTER FABRIC

FILTER FABRIC BURIAL DETAIL

PLAN SYMBOL

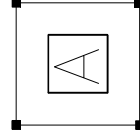

South Carolina Department of
Health and Environmental Control

Type A

FILTER FABRIC INLET PROTECTION

STANDARD DRAWING NO. SC-07 PAGE 1 of 2

NOT TO SCALE

FEBRUARY 2014
DATE

TYPE A – FILTER FABRIC REQUIREMENTS

1. Silt fence must be composed of woven geotextile filter fabric that consists of the following requirements:
 - Composed of fibers consisting of long chain synthetic polymers of at least 85% by weight of polyolefins, polyesters, or polyamides that are formed into a network such that the filaments or yarns retain dimensional stability relative to each other;
 - Free of any treatment or coating which might adversely alter its physical properties after installation;
 - Free of any defects or flaws that significantly affect its physical and/or filtering properties; and,
 - Have a minimum width of 36–inches.
2. Use only fabric appearing on SC DOT's Qualified Products Listing (QPL), Approval Sheet #34, meeting the requirements of the most current edition of the SC DOT Standard Specifications for Highway Construction.
3. 12–inches of the fabric should be placed within excavated trench and toed in when the trench is backfilled.
4. Filter Fabric shall be purchased in continuous rolls and cut to the length of the barrier to avoid joints.
5. Filter Fabric shall be installed at a minimum of 24–inches above the ground.

TYPE A – POST REQUIREMENTS

1. Silt Fence posts must be 48–inch long steel posts that meet, at a minimum, the following physical characteristics.
 - Composed of a high strength steel with a minimum yield strength of 50,000 psi.
 - Include a standard "T" section with a nominal face width of 1.38–inches and a nominal "T" length of 1.48–inches.
 - Weigh 1.25 pounds per foot (\pm 8%)
2. Posts shall be equipped with projections to aid in fastening of filter fabric.
3. Install posts to a minimum of 24–inches. A minimum height of 1– to 2– inches above the fabric shall be maintained, and a maximum height of 3 feet shall be maintained above the ground.
4. Post spacing shall be at a maximum of 3–feet on center.

TYPE A – INSPECTION & MAINTENANCE

1. The key to functional inlet protection is weekly inspections, routine maintenance, and regular sediment removal.
2. Regular inspections of inlet protection shall be conducted once every calendar week and, as recommended, within 24–hours after each rainfall event that produces 1/2–inch or more of precipitation.
3. Attention to sediment accumulations along the filter fabric is extremely important. Accumulated sediment should be continually monitored and removed when necessary.
4. Remove accumulated sediment when it reaches 1/3 the height of the filter fabric. When a sump is installed in front of the fabric, sediment should be removed when it fills approximately 1/3 the depth of the sump.
5. Removed sediment shall be placed in stockpile storage areas or spread thinly across disturbed area. Stabilize the removed sediment after it is relocated.
6. Check for areas where stormwater runoff has eroded a channel beneath the filter fabric, or where the fabric has sagged or collapsed due to runoff overtopping the inlet protection.
7. Check for tears within the filter fabric, areas where fabric has begun to decompose, and for any other circumstance that may render the inlet protection ineffective. Removed damaged fabric and reinstall new filter fabric immediately.
8. Inlet protection structures should be removed after all the disturbed areas are permanently stabilized. Remove all construction material and sediment, and dispose of them properly. Grade the disturbed area to the elevation of the drop inlet structure crest. Stabilize all bare areas immediately.

South Carolina Department of Health and Environmental Control

Type A

FILTER FABRIC INLET PROTECTION

STANDARD DRAWING NO. SC-07 PAGE 2 of 2

GENERAL NOTES

FEBRUARY 2014

DATE

2" x 2" WOOD STAKES
or 1.25 #/FT
STEEL POSTS

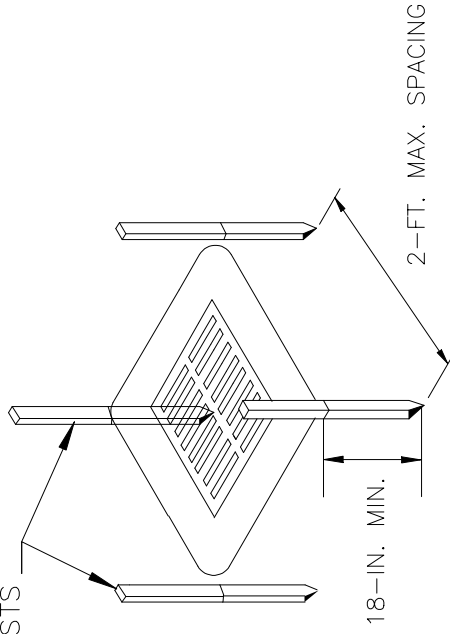

POST INSTALLATION DETAIL

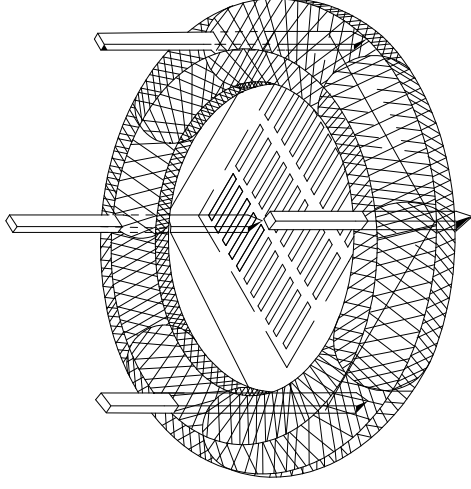

SEDIMENT TUBE INSTALLATION
DETAIL

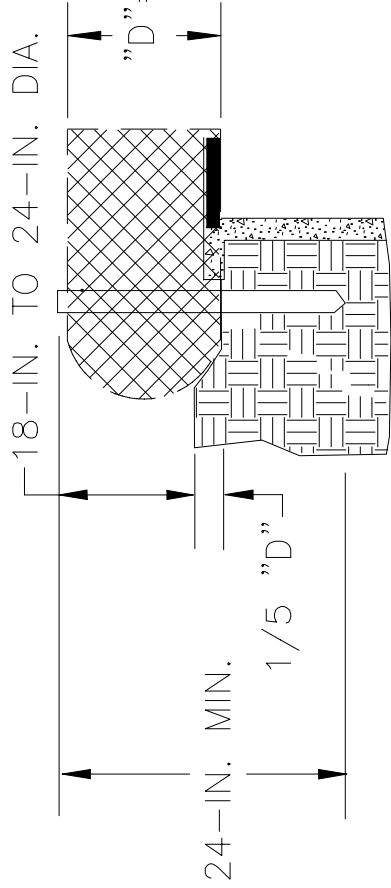

SEDIMENT TUBE BURIAL DETAIL

PLAN SYMBOL

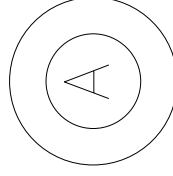

**South Carolina Department of
Health and Environmental Control**

Type A
SEDIMENT TUBE INLET PROTECTION

STANDARD DRAWING NO. SC-07A PAGE 1 of 2

NOT TO SCALE

FEBRUARY 2014
DATE _____

TYPE A – SEDIMENT TUBE INLET PROTECTION GENERAL NOTES

1. Sediment tubes are elongated tubes of compacted geotextiles, curled excelsior wood, natural coconut fiber, or hardwood mulch. Straw, pine needle, and leaf mulch-filled sediment tubes are not permitted.
2. The outer netting of the sediment tube should consist of seamless, high-density polyethylene photodegradable materials treated with ultraviolet stabilizers or a seamless, high-density polyethylene non-degradable material.
3. Sediment tube diameters shall range from 18-inches to 24-inches. Sediment tubes with smaller diameters are prohibited when used as inlet protection.
4. Curled excelsior wood, or natural coconut products that are rolled up to create a sediment tube are not allowed.
5. Sediment tubes should be staked using wooden oak stakes (2-inch X 2-inch) or steel posts (standard "U" or "T" sections with a minimum weight of 1.25 pounds per foot) at a minimum of 48-inches in length placed on 2-foot centers.
6. Install all sediment tubes to ensure that no gaps exist between the soil and the bottom of the tube. Manufacturer's recommendations should always be consulted before installation.
7. The ends of adjacent sediment tubes should be overlapped 6-inches to prevent flow and sediment from passing through the field joint.
8. Sediment tubes should not be stacked on top of one another.
9. Each sediment tube should be installed in a trench with a depth equal to 1/5 the diameter of the sediment tube.
10. Install stakes at a diagonal facing incoming runoff.

INSPECTION & MAINTENANCE

1. The key to functional inlet protection is weekly inspections, routine maintenance, and regular sediment removal.
2. Regular inspections of sediment tube inlet protection shall be conducted once every calendar week and, as recommended, within 24-hours after each rainfall even that produces 1/2-inch or more of precipitation.
3. Attention to sediment accumulations in front of the sediment tube is extremely important. Accumulated sediment should be continually monitored and removed when necessary.
4. Remove accumulated sediment when it reaches 1/3 the height of the sediment tube. When a sump is installed in front of the inlet protection, sediment shall be removed when it fills approximately 1/3 the depth of the sump.
5. Removed sediment shall be placed in stockpile storage areas or spread thinly across disturbed area. Stabilize the removed sediment after it is relocated.
6. Large debris, trash, and leaves should be removed from in front of tubes when found.
7. Inlet protection structures should be removed after the disturbed areas are permanently stabilized. Remove all construction material and sediment, and dispose of them properly. Grade the disturbed area to the elevation of the drop inlet structure crest. Stabilize all bare areas immediately.

**South Carolina Department of
Health and Environmental Control**

Type A

SEDIMENT TUBE INLET PROTECTION

STANDARD DRAWING NO. SC-07A PAGE 2 of 2

FEBRUARY 2014

DATE

NOT TO SCALE

Project Name: USC McKissick Brick Repairs
Project Number: H27-Z327

University of South Carolina

CONTRACTOR'S ONE YEAR GUARANTEE

STATE OF _____

COUNTY OF _____

WE _____
as Contractor on the above-named project, do hereby guarantee that all work executed under the requirements of the Contract Documents shall be free from defects due to faulty materials and /or workmanship for a period of one (1) year from date of acceptance of the work by the Owner and/or Architect/Engineer; and hereby agree to remedy defects due to faulty materials and/or workmanship, and pay for any damage resulting wherefrom, at no cost to the Owner, provided; however, that the following are excluded from this guarantee;

Defects or failures resulting from abuse by Owner.

Damage caused by fire, tornado, hail, hurricane, acts of God, wars, riots, or civil commotion.

[Name of Contracting Firm]

*By _____

Title _____

*Must be executed by an office of the Contracting Firm.

SWORN TO before me this
_____ day of _____, 2____ (seal)

_____ State

My commission expires _____

SECTION 312000 - EARTH MOVING

PART 1 - GENERAL

1.1 SUMMARY

A. Section Includes:

1. Excavating and filling for rough grading the Site.
2. Preparing subgrades for walks.
3. Drainage course for concrete slabs-on-grade.
4. Subbase course for concrete walks.

1.2 DEFINITIONS

A. Backfill: Soil material used to fill an excavation.

1. Initial Backfill: Backfill placed beside and over pipe in a trench, including haunches to support sides of pipe.
2. Final Backfill: Backfill placed over initial backfill to fill a trench.

B. Base Course: Aggregate layer placed between the subbase course and hot-mix asphalt paving.

C. Bedding Course: Aggregate layer placed over the excavated subgrade in a trench before laying pipe.

D. Borrow Soil: Satisfactory soil imported from off-site for use as fill or backfill.

E. Drainage Course: Aggregate layer supporting the slab-on-grade that also minimizes upward capillary flow of pore water.

F. Excavation: Removal of material encountered above subgrade elevations and to lines and dimensions indicated.

1. Authorized Additional Excavation: Excavation below subgrade elevations or beyond indicated lines and dimensions as directed by Architect. Authorized additional excavation and replacement material will be paid for according to Contract provisions for changes in the Work.
2. Unauthorized Excavation: Excavation below subgrade elevations or beyond indicated lines and dimensions without direction by Architect. Unauthorized excavation, as well as remedial work directed by Architect, shall be without additional compensation.

G. Fill: Soil materials used to raise existing grades.

H. Structures: Buildings, footings, foundations, retaining walls, slabs, tanks, curbs, mechanical and electrical appurtenances, or other man-made stationary features constructed above or below the ground surface.

USC McKissick Plaza Improvements

- I. Subbase Course: Aggregate layer placed between the subgrade and base course for hot-mix asphalt pavement, or aggregate layer placed between the subgrade and a cement concrete pavement or a cement concrete or hot-mix asphalt walk.
- J. Subgrade: Uppermost surface of an excavation or the top surface of a fill or backfill immediately below subbase, drainage fill, drainage course, or topsoil materials.
- K. Utilities: On-site underground pipes, conduits, ducts, and cables as well as underground services within buildings.

1.3 INFORMATIONAL SUBMITTALS

- A. Material test reports.

1.4 FIELD CONDITIONS

- A. Utility Locator Service: Notify utility locator service for area where Project is located before beginning earth-moving operations.
- B. Do not commence earth-moving operations until plant-protection measures specified in Section 015639 "Temporary Tree and Plant Protection" are in place.

PART 2 - PRODUCTS

2.1 SOIL MATERIALS

- A. General: Provide borrow soil materials when sufficient satisfactory soil materials are not available from excavations.
- B. Satisfactory Soils: Soil Classification Groups GW, GP, GM, SW, SP, and SM according to ASTM D 2487, or a combination of these groups; free of rock or gravel larger than 3 inches (75 mm) in any dimension, debris, waste, frozen materials, vegetation, and other deleterious matter.
- C. Unsatisfactory Soils: Soil Classification Groups GC, SC, CL, ML, OL, CH, MH, OH, and PT according to ASTM D 2487, or a combination of these groups.
 - 1. Unsatisfactory soils also include satisfactory soils not maintained within 2 percent of optimum moisture content at time of compaction.
- D. Subbase Material: Naturally or artificially graded mixture of natural or crushed gravel, crushed stone, and natural or crushed sand; ASTM D 2940/D 2940M; with at least 90 percent passing a 1-1/2-inch (37.5-mm) sieve and not more than 12 percent passing a No. 200 (0.075-mm) sieve.
- E. Base Course: Naturally or artificially graded mixture of natural or crushed gravel, crushed stone, and natural or crushed sand; ASTM D 294/D 2940M 0; with at least 95 percent passing a 1-1/2-inch (37.5-mm) sieve and not more than 8 percent passing a No. 200 (0.075-mm) sieve.

USC McKissick Plaza Improvements

- F. Engineered Fill: Naturally or artificially graded mixture of natural or crushed gravel, crushed stone, and natural or crushed sand; ASTM D 2940/D 2940M; with at least 90 percent passing a 1-1/2-inch (37.5-mm) sieve and not more than 12 percent passing a No. 200 (0.075-mm) sieve.
- G. Bedding Course: Naturally or artificially graded mixture of natural or crushed gravel, crushed stone, and natural or crushed sand; ASTM D 2940/D 2940M; except with 100 percent passing a 1-inch (25-mm) sieve and not more than 8 percent passing a No. 200 (0.075-mm) sieve.
- H. Drainage Course: Narrowly graded mixture of washed crushed stone, or crushed or uncrushed gravel; ASTM D 448; coarse-aggregate grading Size 57; with 100 percent passing a 1-1/2-inch (37.5-mm) sieve and zero to 5 percent passing a No. 8 (2.36-mm) sieve.

PART 3 - EXECUTION

3.1 PREPARATION

- A. Protect structures, utilities, sidewalks, pavements, and other facilities from damage caused by settlement, lateral movement, undermining, washout, and other hazards created by earth-moving operations.
- B. Protect and maintain erosion and sedimentation controls during earth-moving operations.
- C. Protect subgrades and foundation soils from freezing temperatures and frost. Remove temporary protection before placing subsequent materials.

3.2 EXCAVATION, GENERAL

- A. Unclassified Excavation: Excavate to subgrade elevations regardless of the character of surface and subsurface conditions encountered. Unclassified excavated materials may include rock, soil materials, and obstructions. No changes in the Contract Sum or the Contract Time will be authorized for rock excavation or removal of obstructions.
 - 1. If excavated materials intended for fill and backfill include unsatisfactory soil materials and rock, replace with satisfactory soil materials.

3.3 EXCAVATION FOR STRUCTURES

- A. Excavate to indicated elevations and dimensions within a tolerance of plus or minus 1 inch (25 mm). If applicable, extend excavations a sufficient distance from structures for placing and removing concrete formwork, for installing services and other construction, and for inspections.
 - 1. Excavations for Footings and Foundations: Do not disturb bottom of excavation. Excavate by hand to final grade just before placing concrete reinforcement. Trim bottoms to required lines and grades to leave solid base to receive other work.
- B. Excavations at Edges of Tree- and Plant-Protection Zones:

USC McKissick Plaza Improvements

1. Excavate by hand or with an air spade to indicated lines, cross sections, elevations, and subgrades. If excavating by hand, use narrow-tine spading forks to comb soil and expose roots. Do not break, tear, or chop exposed roots. Do not use mechanical equipment that rips, tears, or pulls roots.
2. Cut and protect roots according to requirements in Section 015639 "Temporary Tree and Plant Protection."

3.4 EXCAVATION FOR WALKS AND PAVEMENTS

- A. Excavate surfaces under walks and pavements to indicated lines, cross sections, elevations, and subgrades.

3.5 SUBGRADE INSPECTION

- A. Proof-roll subgrade below the building slabs and pavements with a pneumatic-tired dump truck or roller to identify soft pockets and areas of excess yielding. Do not proof-roll wet or saturated subgrades.
- B. Reconstruct subgrades damaged by freezing temperatures, frost, rain, accumulated water, or construction activities, as directed by Architect, without additional compensation.

3.6 UNAUTHORIZED EXCAVATION

- A. Fill unauthorized excavation under foundations or wall footings by extending bottom elevation of concrete foundation or footing to excavation bottom, without altering top elevation. Lean concrete fill, with 28-day compressive strength of 2500 psi (17.2 MPa), may be used when approved by Architect.
 1. Fill unauthorized excavations under other construction, pipe, or conduit as directed by Architect.

3.7 STORAGE OF SOIL MATERIALS

- A. Stockpile borrow soil materials and excavated satisfactory soil materials without intermixing. Place, grade, and shape stockpiles to drain surface water. Cover to prevent windblown dust.
 1. Stockpile soil materials away from edge of excavations. Do not store within drip line of remaining trees.

3.8 SOIL FILL

- A. Plow, scarify, bench, or break up sloped surfaces steeper than 1 vertical to 4 horizontal so fill material will bond with existing material.
- B. Place and compact fill material in layers to required elevations as follows:
 1. Under grass and planted areas, use satisfactory soil material.

2. Under walks and pavements, use satisfactory soil material.
3. Under steps and ramps, use engineered fill.
4. Under building slabs, use engineered fill.
5. Under footings and foundations, use engineered fill.

3.9 SOIL MOISTURE CONTROL

- A. Uniformly moisten or aerate subgrade and each subsequent fill or backfill soil layer before compaction to within 2 percent of optimum moisture content.
 1. Do not place backfill or fill soil material on surfaces that are muddy, frozen, or contain frost or ice.
 2. Remove and replace, or scarify and air dry, otherwise satisfactory soil material that exceeds optimum moisture content by 2 percent and is too wet to compact to specified dry unit weight.

3.10 COMPACTION OF SOIL BACKFILLS AND FILLS

- A. Place backfill and fill soil materials in layers not more than 8 inches (200 mm) in loose depth for material compacted by heavy compaction equipment and not more than 4 inches (100 mm) in loose depth for material compacted by hand-operated tampers.
- B. Place backfill and fill soil materials evenly on all sides of structures to required elevations and uniformly along the full length of each structure.
- C. Compact soil materials to not less than the following percentages of maximum dry unit weight according to ASTM D 698:
 1. Under structures, building slabs, steps, and pavements, scarify and recompact top 12 inches (300 mm) of existing subgrade and each layer of backfill or fill soil material at 95 percent.
 2. Under walkways, scarify and recompact top 6 inches (150 mm) below subgrade and compact each layer of backfill or fill soil material at 92 percent.
 3. Under turf or unpaved areas, scarify and re-compact top 6 inches (150 mm) below subgrade and compact each layer of backfill or fill soil material at 85 percent.

3.11 GRADING

- A. General: Uniformly grade areas to a smooth surface, free of irregular surface changes. Comply with compaction requirements and grade to cross sections, lines, and elevations indicated.
- B. Site Rough Grading: Slope grades to direct water away from buildings and to prevent ponding. Finish subgrades to elevations required to achieve indicated finish elevations, within the following subgrade tolerances:
 1. Turf or Unpaved Areas: Plus or minus 1 inch (25 mm).
 2. Walks: Plus or minus 1/2 inch (25 mm).
 3. Pavements: Plus or minus 1/2 inch (13 mm).

3.12 SUBBASE AND BASE COURSES UNDER PAVEMENTS AND WALKS

- A. Place subbase course and base course on subgrades free of mud, frost, snow, or ice.
- B. On prepared subgrade, place subbase course and base course under pavements and walks as follows:
 - 1. Shape subbase course and base course to required crown elevations and cross-slope grades.
 - 2. Place subbase course and base course that exceeds 6 inches (150 mm) in compacted thickness in layers of equal thickness, with no compacted layer more than 6 inches (150 mm) thick or less than 3 inches (75 mm) thick.
 - 3. Compact subbase course and base course at optimum moisture content to required grades, lines, cross sections, and thickness to not less than 95 percent of maximum dry unit weight according to ASTM D 698.

3.13 DRAINAGE COURSE UNDER CONCRETE SLABS-ON-GRADE

- A. Place drainage course on subgrades free of mud, frost, snow, or ice.
- B. On prepared subgrade, place and compact drainage course under cast-in-place concrete slabs-on-grade as follows:
 - 1. Place drainage course that exceeds 6 inches (150 mm) in compacted thickness in layers of equal thickness, with no compacted layer more than 6 inches (150 mm) thick or less than 3 inches (75 mm) thick.
 - 2. Compact each layer of drainage course to required cross sections and thicknesses to not less than 95 percent of maximum dry unit weight according to ASTM D 698.

3.14 FIELD QUALITY CONTROL

- A. Testing Agency: Owner will engage a qualified geotechnical engineering testing agency to perform tests and inspections.
- B. Allow testing agency to inspect and test subgrades and each fill or backfill layer. Proceed with subsequent earth moving only after test results for previously completed work comply with requirements.
- C. Footing Subgrade: At footing subgrades, at least one test of each soil stratum will be performed to verify design bearing capacities. Subsequent verification and approval of other footing subgrades may be based on a visual comparison of subgrade with tested subgrade when approved by Architect.
- D. When testing agency reports that subgrades, fills, or backfills have not achieved degree of compaction specified, scarify and moisten or aerate, or remove and replace soil materials to depth required; re-compact and retest until specified compaction is obtained.

USC McKissick Plaza Improvements

3.15 PROTECTION

- A. Protecting Graded Areas: Protect newly graded areas from traffic, freezing, and erosion. Keep free of trash and debris.
- B. Repair and reestablish grades to specified tolerances where completed or partially completed surfaces become eroded, rutted, settled, or where they lose compaction due to subsequent construction operations or weather conditions.
- C. Where settling occurs before Project correction period elapses, remove finished surfacing, backfill with additional soil material, compact, and reconstruct surfacing.
 - 1. Restore appearance, quality, and condition of finished surfacing to match adjacent work, and eliminate evidence of restoration to greatest extent possible.

3.16 DISPOSAL OF SURPLUS AND WASTE MATERIALS

- A. Remove surplus satisfactory soil and waste materials, including unsatisfactory soil, trash, and debris, and legally dispose of them off Owner's property.

END OF SECTION 312000

SECTION 321400 - UNIT PAVING

PART 1 - GENERAL

1.1 RELATED DOCUMENTS

- A. Drawings and general provisions of the Contract, including General and Supplementary Conditions and Division 01 Specification Sections, apply to this Section.

1.2 SUMMARY

- A. Section Includes:
 - 1. Brick pavers set in aggregate and mortar setting beds.
 - 2. Metal edge restraints.

1.3 ACTION SUBMITTALS

- A. Product Data: For materials other than water and aggregates.
- B. Samples: For each type of unit paver indicated and the following:
 - 1. Joint materials involving color selection.
 - 2. Exposed edge restraints involving color selection.

1.4 INFORMATIONAL SUBMITTALS

- A. Material Certificates: For unit pavers. Include statements of material properties indicating compliance with requirements, including compliance with standards. Provide for each type and size of unit.

1.5 FIELD CONDITIONS

- A. Cold-Weather Protection: Do not use frozen materials or materials mixed or coated with ice or frost. Do not build on frozen subgrade or setting beds. Remove and replace unit paver work damaged by frost or freezing.
- B. Weather Limitations for Mortar and Grout:
 - 1. Cold-Weather Requirements: Comply with cold-weather construction requirements contained in TMS 602/ACI 530.1/ASCE 6.
 - 2. Hot-Weather Requirements: Comply with hot-weather construction requirements contained in TMS 602/ACI 530.1/ASCE 6. Provide artificial shade and windbreaks and use cooled materials as required. Do not apply mortar to substrates with temperatures of 100 deg F (38 deg C) and higher.

PART 2 - PRODUCTS

2.1 BRICK PAVERS

- A. Brick Pavers: Light-traffic paving brick; ASTM C 902, Class SX, Type I Application PS. Provide brick without frogs or cores in surfaces exposed to view in the completed Work.

For McKissick Area:

1. Thickness: 2-1/4 inches (57 mm)
2. Face Size: 4 by 8 inches (102 by 203 mm)
3. "Color" Subparagraph below may be deleted if manufacturer's product designation is used and specifies color.
4. Color: Equal to 'Pathway Red' by Pine Hall Brick
5. Specialty Brick: Match existing cream-colored brick in initial pattern.

- B. Temporary Protective Coating: Precoat exposed surfaces of brick pavers with a continuous film of a temporary protective coating that is compatible with brick, mortar, and grout products and can be removed without damaging grout or brick. Do not coat unexposed brick surfaces; handle brick to prevent coated surfaces from contacting backs or edges of other units. If, despite these precautions, coating does contact bonding surfaces of brick, remove coating from bonding surfaces before setting brick.

- C. Steel Edge Restraints: Manufacturer's standard painted steel edging 3/16 inch (4.8 mm) thick by 4 inches (100 mm) high] with loops pressed from or welded to face to receive stakes at 36 inches (900 mm) o.c. and steel stakes 15 inches (380 mm) long for each loop.

1. Manufacturers: Subject to compliance with requirements, available manufacturers offering products that may be incorporated into the Work include, but are not limited to, the following:

- a. Border Concepts, Inc.
- b. Collier Metal Specialties, Inc.
- c. J. D. Russell Company (The).
- d. Sure-loc Edging Corporation.

- D. Aluminum Edge Restraints: Manufacturer's standard [L-shaped, 1/8-inch- (3.2-mm-) thick by 1-3/8-inch- (35-mm-) high extruded-aluminum edging with loops pressed from face to receive stakes at 12 inches (300 mm) o.c. and aluminum stakes 12 inches (300 mm) long for each loop.

1. Manufacturers: Subject to compliance with requirements, available manufacturers offering products that may be incorporated into the Work include, but are not limited to the following:

- a. Curv-Rite, Inc.
- b. Permaloc Corporation.
- c. Sure-loc Edging Corporation.

2.2 ACCESSORIES

- A. Compressible Foam Filler: Preformed strips complying with ASTM D 1056, Grade 2A1.

2.3 AGGREGATE SETTING-BED MATERIALS

- A. Graded Aggregate for Base: Sound, crushed stone or gravel complying with ASTM D 448 for Size No. 8.
- B. Leveling Course: Sound, sharp, washed, natural crushed stone complying with gradation requirements in ASTM C 33/C 33M for fine aggregate.
- C. Stone Screenings for Leveling Course: sound stone screenings complying with ASTM D 448 for size No. 10.
- D. Sand for Joints: Fine, sharp, washed, natural sand or crushed stone with 100 percent passing No. 16 (1.18-mm) sieve and no more than 10 percent passing No. 200 (0.075-mm) sieve.
- E. Drainage Geotextile: Nonwoven needle-punched geotextile fabric, manufactured for subsurface drainage applications, made from polyolefins or polyesters; with elongation greater than 50 percent; complying with AASHTO M 288 and the following, measured per test methods referenced:
- F. Herbicide: Commercial chemical for weed control, registered with the EPA. Provide in granular, liquid, or wettable powder form.

2.4 MORTAR SETTING-BED MATERIALS

- A. Portland Cement: ASTM C 150/C 150M, Type I or Type II.
- B. Hydrated Lime: ASTM C 207, Type S.
- C. Sand: ASTM C 144.
- D. Water: Potable.

2.5 GROUT MATERIALS

- A. High-Performance Cement Grout: ANSI A118.7, sanded.
- B. Grout Colors: As selected by Architect from manufacturer's full range.
- C. Water: Potable.

2.6 MORTAR AND GROUT MIXES

- A. General: Comply with referenced standards and with manufacturers' written instructions for mix proportions, mixing equipment, mixer speeds, mixing containers, mixing times, and other

procedures needed to produce setting-bed and joint materials of uniform quality and with optimal performance characteristics. Discard mortars and grout if they have reached their initial set before being used.

- B. Mortar-Bed Bond Coat: Mix neat cement or cement and sand with to a creamy consistency.
- C. Portland Cement-Lime Setting-Bed Mortar: Type M complying with ASTM C 270, Proportion Specification.
- D. Job-Mixed Portland Cement Grout: Proportion and mix job-mixed Portland cement and sand to match setting bed mortar, except omit hydrated lime and use enough water to produce a porable mixture.

PART 3 - EXECUTION

3.1 INSTALLATION, GENERAL

- A. Mix pavers from several pallets or cubes, as they are placed, to produce uniform blend of colors and textures. Where existing pavers are re-used, clean old mortar joints from pavers. Mix any batches of varying colors to produce an overall blend.
- B. Cut unit pavers with motor-driven masonry saw equipment to provide clean, sharp, unchipped edges. Cut units to provide pattern indicated and to fit adjoining work neatly. Use full units without cutting where possible. Avoid small pieces less than one-half brick by distributing cuts across several bricks. Hammer cutting is not acceptable.
- C. Joint Pattern:
 - 1. McKissick area: Basket weave
- D. Expansion and Control Joints: Provide for sealant-filled joints at locations and of widths indicated. Provide compressible foam filler as backing for sealant-filled joints unless otherwise indicated; Install joint filler before setting pavers. Sealant materials and installation are specified in Section 079200 "Joint Sealants."
- E. Provide edge restraints as indicated. Install edge restraints before placing unit pavers.

3.2 AGGREGATE SETTING-BED APPLICATIONS

- A. Compact soil subgrade uniformly to at least 95 percent of ASTM D 698 laboratory density.
- B. Place aggregate base, compact by tamping with plate vibrator, and screed to depth indicated.
- C. Place drainage geotextile over compacted base course, overlapping ends and edges at least 12 inches (300 mm).
- D. Place leveling course and screed to a thickness of 1 to 1-1/2 inches (25 to 38 mm), taking care that moisture content remains constant and density is loose and uniform until pavers are set and compacted.

- E. Treat leveling course with herbicide to inhibit growth of grass and weeds.
- F. Set pavers with a minimum joint width of 1/16 inch (1.5 mm) and a maximum of 1/8 inch (3 mm), being careful not to disturb leveling base. If pavers have spacer bars, place pavers hand tight against spacer bars. Use string lines to keep straight lines. Fill gaps between units that exceed 3/8 inch (10 mm) with pieces cut to fit from full-size unit pavers.
- G. Vibrate pavers into leveling course with a low-amplitude plate vibrator capable of a 3500- to 5000-lbf (16- to 22-kN) compaction force at 80 to 90 Hz. Use vibrator with neoprene mat on face of plate or other means as needed to prevent cracking and chipping of pavers. Perform at least three passes across paving with vibrator.
 - 1. Vibrate after edge pavers are installed and there is a completed surface, or before surface is exposed to rain.
 - 2. Before ending each day's work, fully compact installed pavers to within 36 inches of the laying face. Cover pavers that have not been compacted, and any exposed leveling course, with non-staining plastic sheets to protect them from rain.
- H. Spread dry sand and fill joints immediately after vibrating pavers into leveling course. Vibrate pavers and add sand until joints are completely filled, then remove excess sand. Leave a slight surplus of sand on the surface for joint filling.
- I. Repeat joint filling process 30 days later.

3.3 MORTAR SETTING-BED APPLICATIONS

- A. Saturate concrete subbase with clean water several hours before placing setting bed. Remove surface water about one hour before placing setting bed.
- B. Apply mortar-bed bond coat over surface of concrete subbase about 15 minutes before placing mortar bed. Do not exceed 1/16-inch (1.6-mm) thickness for bond coat. Limit area of bond coat to avoid its drying out before placing setting bed.
- C. Apply mortar bed over bond coat; spread and screed mortar bed to uniform thickness at subgrade elevations required for accurate setting of pavers to finished grades indicated.
- D. Mix and place only that amount of mortar bed that can be covered with pavers before initial set. Before placing pavers, cut back, bevel edge, and remove and discard setting-bed material that has reached initial set.
- E. Wet brick pavers before laying if the initial rate of absorption exceeds 30 g/30 sq. in. per minute when tested according to ASTM C 67. Allow units to absorb water so they are damp but not wet at time of laying.
- F. Place pavers before initial set of cement occurs. Immediately before placing pavers on mortar bed, apply uniform 1/16-inch- thick bond coat to mortar bed or to back of each paver with a flat trowel.
- G. Tamp or beat pavers with a wooden block or rubber mallet to obtain full contact with setting bed and to bring finished surfaces within indicated tolerances. Set each paver in a single

operation before initial set of mortar; do not return to areas already set or disturb pavers for purposes of realigning finished surfaces or adjusting joints.

- H. Spaced Joint Widths: Provide 3/8-inch (10-mm) nominal joint width with variations not exceeding plus or minus 1/8 inch (3 mm).
- I. Grouted Joints: Grout paver joints complying with ANSI A108.10.
- J. Grout joints as soon as possible after initial set of setting bed.
 - 1. Force grout into joints, taking care not to smear grout on adjoining surfaces.
 - 2. Tool exposed joints slightly concave when thumbprint hard, using a jointer larger than joint thickness unless otherwise indicated.
- K. Cure grout by maintaining in a damp condition for seven days unless otherwise recommended by grout or liquid-latex manufacturer.

3.4 MORTAR SETTING-BED APPLICATIONS

- A. Remove and replace unit pavers that are loose, chipped, broken, stained, or otherwise damaged or that do not match adjoining units. Provide new units to match adjoining units and install in the same manner as original units, with same joint treatment and no evidence of replacement.
- B. Pointing. During tooling of joints, enlarge voids or holes and completely fill with grout. Point up joints at sealant joints to provide a neat, uniform appearance, properly prepared for sealant application.
- C. Cleaning: Remove excess grout from exposed paver surfaces; wash and scrub clean.
 - 1. Remove temporary protective coating as recommended by coating manufacturer and as acceptable to paver and grout manufacturers.

END OF SECTION 321400

University of South Carolina
McKissick Brick Repairs

SECTION 328400- UNDERGROUND IRRIGATION SYSTEM

PART 1 - GENERAL

1.01 DESCRIPTION OF WORK:

- A. The work covered by this Section consists of furnishing all labor, equipment and materials and performing all operations necessary for installing an automatic irrigation system as shown on the Drawing and/or described by these Specifications. The work includes: preparation and excavation of trenches, installation of irrigation system (including: plastic pipe, fittings and connectors, sprinkler heads, automatic control valves and valve boxes, drip accessories, electric control cable, wiring to controller and required submittals).

1.02 QUALITY ASSURANCE:

- A. Subcontract work to a single firm specializing in irrigation systems.
- B. Manufacturer Qualifications. Provide underground sprinkler system as a complete unit produced by a single acceptable manufacturer including heads, valves, piping circuits, controls and accessories.

1.03 SUBMITTALS

- A. Product Data: Submit manufacturer's catalog cuts, equipment data sheets, or shop drawings for the following products:
 - 1. Sprinkler heads
 - 2. Swing Joints
 - 3. Valves: electric and manual
 - 4. Controller and controller accessories
 - 5. Valve boxes
 - 6. Pipe and pipe fittings
 - 7. Control wire and splice connectors
 - 8. Drip components
 - 9. Solvent, primer and Teflon tape
- B. Submit a written proposal and layout plan including a breakdown of components to be used in the system and a complete description of the scope of work. Include all information of plumbing and/or electrical permits and fees. Also include with the written proposal:
 - 1. A letter(s) from the manufacturer(s) of all major components of the system (sprinklers, electric valves, controllers, and drip components) that a local authorized service center exists as described in Section 1.4, C. The name and address of that service center shall be included in the letter. The same letter(s) shall also include the name of the local authorized manufacturer's representative.

PART 2 - PRODUCTS

2.01 SPRINKLER SYSTEM:

University of South Carolina
McKissick Brick Repairs

A. Manufacturer. Irrigation system products shall be by the following manufacturers:

- Rainbird Sprinkler Mfg. Corp. 1-800-247-3782 www.rainbird.com
- Hunter Industries www.hunterindustries.com
- Or approved equals

2.02 GRAVEL:

A. Material for gravel sump shall be pea gravel or approved equal.

2.03 PLASTIC PIPE AND FITTINGS:

- A. The plastic pipe shall be rigid unplasticized PVC class 200 or class 160 (SDR 26), unless otherwise noted on drawings, extruded from virgin parent material. The pipe shall be homogeneous throughout and free from visible cracks, holes, foreign materials, blisters, deleterious wrinkles and dents. All plastic pipe shall be manufactured by CertainTeed, Johns-Mansville or approved equal.
- B. All plastic pipe fittings shall be schedule 40 PVC and shall be manufactured by the same manufacturer as the plastic pipe.

2.04 SHRUB AND LAWN SPRINKLER HEADS:

- A. All full and part circle sprinklers shall be of the fixed spray variety as is specified on the Drawing. These sprinklers shall be of the pop-up type with spring retraction. The body of the sprinkler shall be constructed of Cyclocac Material and the sprinkler shall be easily serviced from the Manufacturer's specifications with regard to the diameter of throw and gallonage at a given pressure. Spacing of heads shall not exceed the manufacturer's maximum recommendation.
- B. Matched precipitation will be required on all full and part circle sprinklers operation on the same zone.

2.05 PVC SLEEVING:

A. Schedule 40 PVC pipe shall be as noted on the drawings. These sleeves are to be used for proposed irrigation lines. Irrigation sub-contractor shall coordinate installation with General Contractor.

2.06 AUTOMATIC CONTROL VALVES:

- A. The remote control valve shall be a normally closed 24 volt A.C. 50/60 cycle solenoid type. Valve pressure rating shall not be less than 150 PSI.
- B. The valve body and bonnet shall be constructed of heavy duty glass-filled nylon, diaphragm shall be on nylon reinforced nitrile rubber. Solenoid coil shall be encapsulated in molded epoxy.
- C. The valve body shall be activated by a low power, 2.0 watt 24 volt A.C. solenoid. The solenoid plunger shall have a filter to insure positive valve operation.

University of South Carolina
McKissick Brick Repairs

- D. The valve shall have a flow control stem with wheel handle for regulation or shutting off the flow of water and a bleed screw for manual operation without electrically energizing the solenoid coil.
- E. The valve construction shall be such as to provide for all internal parts to be removable from the top of the valve without disturbing the valve installation.

2.07 VALVE BOXES:

- A. All control valves shall be installed in a valve box in accordance with manufacturer's specifications.

2.08 CONTROL VALVE CABLE:

- A. All wiring to be used for connecting the automatic remote control valve to the automatic controllers shall be Type "UF", 14-1 stranded or solid copper, single conduction wire with PVC insulation and bear UL approval for direct underground burial feeder cable. Wire connections to remote control electric valves and splices of wire in the field shall use Pen-Tite wire connectors or approved equal and scaling cement.

2.09 BACKFLOW PREVENTER:

- A. Install size as indicated on drawings and as per local codes.

2.10 DRIP IRRIGATION ACCESSORIES:

- A. Filter. Provide filter at valve to each drip zone. Provide screen having equivalent of 140-mesh filtration capacity.
- B. Pressure Regulator. Incorporate regulator into each drip system if supply pressure exceeds 40 PSI.
- C. Closure Caps. Provide in accordance with manufacturer's recommendations.

2.11 AUTOMATIC CONTROLLER:

- A. The controller shall be capable of operating 24 V.A.C. electric remote control valves. The controller shall have an active day light with timing accurate to 1 minute per month. (See plan for more specific information).
- B. The wall mount type controller cabinet shall be of injection molded high impact plastic which shall resist corrosion and provide for an attractive appearance. The door shall be mated with the other cabinet parts and be made of the same material. The controller shall be wall mounted as shown on the irrigation plan. The controller shall have adequate lightning protection.
- C. Coordinate location of controller-associated weather station or sensor units with Landscape Architect.

PART 3 - EXECUTION

3.01 LAYOUT OF LINES:

University of South Carolina
McKissick Brick Repairs

- A. The water lines will be laid at the locations shown on the plans. The Landscape Contractor shall stake out the location of each run of pipe and all sprinkler heads or valve locations for approval by Landscape Architect prior to digging trench.
- B. The lawn irrigation system shall be installed so that it will drain at all points.
- C. Install PVC pipe in dry weather when temperature is above 40° F in strict accordance with manufacturer's instructions. Allow joints to cure at least 24 hours at temperature above 40° F (4°C) before testing unless otherwise recommended by manufacturer.

3.02 EXCAVATION AND BACKFILL:

- A. Trenches for PVC pipe main lines shall be excavated to sufficient depth of 12" minimum and an unspecified width to permit proper handling and installation of pipe and fittings. Trenches for PVC pipe lateral sprinkler lines shall be excavated to sufficient depth of 12" minimum and an unspecified width to permit proper handling and installation of pipe and fittings.
- B. On sodded areas the Landscape Contractor will remove and replace the sod where possible from the trench area to the necessary width and depth required to facilitate his installation.
- C. The backfill shall be thoroughly compacted and brought to finish grade, with proper allowance for topsoil. Selected dirt or sand shall be used if soil conditions are rocky. In rocky areas the trenching depth shall be two inches (2") below normal trench depth to allow for this bedding. The pea gravel fill shall be used in filling the top 4" above the pipe. The remainder of the backfill shall contain no lumps or rocks larger than three inches (3"). The top six inches (6") of backfill shall be free of rocks over one inch (1") diameter, subsoil or trash.

3.03 PLASTIC PIPE AND FITTINGS:

- A. All pipe fittings and valves, etc. shall be installed and joined in accordance with the manufacturer's recommendations. Interior of pipes shall be kept free from dirt and debris and when pipe laying is not in progress, open ends of pipe shall be closed by approved means.
- B. Pipe shall be firmly supported throughout its entire length. Extreme care shall be exercised to prevent low points except at drains so that every section of pipe is placed with positive gravity drainage flow towards a drain valve.
- C. Sharp changes in alignment and grade shall be made with appropriate fittings. All elbows, tees and fittings shall be installed with a reaction block bearing against undisturbed soil to prevent breakage or separation of the joint.

3.04 AUTOMATIC CONTROL VALVES:

- A. Automatic control valves shall be installed in accordance with the manufacturer's specifications.

3.05 VALVE BOXES:

- A. Valve boxes shall be installed on a suitable base of gravel for proper foundation box and easy leveling of box to proper grade and also to provide proper drainage of the box. All valve boxes shall be provided with the proper size extensions, wherever required, to bring the valve boxes level with the finished grade.

University of South Carolina
McKissick Brick Repairs

3.06 ELECTRICAL INSTALLATION:

- A. The Contractor will be required to make connections to the building electrical system as is required for the proper operation of the automatic control system. The entire installation shall fully comply with all local and state laws and ordinances and with all the established codes applicable thereto.
- B. All control circuitry, whether electrical or hydraulic, passing through the wall of the building or beneath a sidewalk, road or drive shall be installed in a suitable sleeve; whereas in all other locations they shall be installed in the pipe trench and protected by the pipe whenever possible.
- C. The joining of all underground wires shall be by the use of wire nuts covered with Scotch Lok per installation instructions provided by manufacturer.

3.07 CONTROL VALVE CABLE:

- A. All control valve cables shall be installed by direct burial at a minimum depth of 12". Where practical the wire shall be installed in same trench as mainline pipe.
- B. Extreme care shall be exercised during backfilling of trench to avoid damage and displacement of mainline pipe.
- C. Control valve cable shall be fed through conduit from inside the building.
- D. Each control valve shall be connected to one station of the controller by a control wire. All of the valves shall be connected to a common ground.

3.08 SPRINKLER HEADS:

- A. Sprinkler heads shall be installed in accordance with manufacturer's specifications.
The height of each sprinkler head in relation to the finish grade shall be approved by the Landscape Architect.

3.09 INSTALLATION OF DRIP IRRIGATION SYSTEM:

- A. Install main lines and valves. Before installing emitter laterals, perform pressure test then flush out sand, plastic shaving and other foreign matter.
- B. Emitter Hose. Bury emitter laterals under 3 inches of mulch. Solvent weld each connection in accordance with manufacturer's recommendation to standard weight Schedule 40 PVC fittings and bushings. Install hose in a serpentine manner. When cutting hose, use a shearing tool such as a pipe cutter, knife or shears. Use only manufacturer's recommended tool and procedure when punching hose for emitters.
- C. Emitter Heads. Connect emitter on a rigid PVC nipple to PVC drip lateral with a tee or elbow. Attach tubing to barbed fitting and daylight distribution tubing at rootball secured with stake. Add bug cap at end of secured distribution tubing. If necessary after installing emitters and before operating system, open end of drip lateral and flush lines clean. The number of emitters on a line shall not exceed manufacturer's recommendations for that hose or distribution tubing size and length.

University of South Carolina
McKissick Brick Repairs

3.10 BACKFLOW PREVENTERS

- A. Install backflow preventer in new connection between connection and control valves, as per local codes.

3.11 FLUSHING:

- A. After all new sprinkler piping and risers are in place and connected for a given section, and all necessary work has been completed and prior to installation of sprinkler heads, all control valves shall be opened and a full head of water shall be flushed through the system to remove any foreign material.

3.12 TESTING:

- A. Tests shall be made on portions of the line as completed. Final testing, however, shall be made on the entire system. Trenches shall be partially backfilled to prevent displacement of pipes.
- B. Pressure test shall be performed to a maximum hydrostatic pressure of 200 PSI based on the elevation of the lowest point in the system and corrected to the elevation of the test gauge. Duration of the pressure test shall be at least one hour.
- C. Leakage test shall be performed after satisfactory completion of the pressure test. The leakage test shall be conducted at a hydrostatic pressure of 130 PSI without showing a leakage in excess 7.5 gallons per hour. Extend the leakage test for a period of time necessary to allow inspection, but in no case shall the duration be less than two hours.
- D. Remove and replace any defective materials of installations discovered in testing and repeat the test until satisfactory to the Landscape Architect. This work shall be performed at the Landscape Contractor's expense.
- E. The tests shall be witnessed by the Landscape Architect.

3.13 RECORD DRAWINGS

- A. After completion of the piping installation, the Landscape Contractor shall furnish a signed Record Drawing showing exact dimensions, depths and locations of all pipe, drains, controls, heads, etc. of sprinkler system. Record Drawing shall also be submitted in AutoCAD format (version 2007 or later) on a CD.

3.14 MAINTENANCE AND OPERATING INSTRUCTIONS:

- A. Provide four (4) hours of instruction for Owner's Representative's personnel upon completion of check/test/start-up/adjust operations. Owner's Representative shall be notified at least one (1) week in advance of check/test/start-up/adjust operations.
- B. Upon completion of the irrigation system and in conjunction with application for final payment, submit one Maintenance and Operation Manual. Each Manual shall be a 3-ring binder with:
 - 1. One (1) hard copy and CD of CAD file of the "RECORD" drawing of the irrigation system, and
 - 2. One (1) complete set of the "APPROVED" Submittals required in paragraph 1.06 above.
 - 3. One (1) copy of the suggested "SYSTEM OPERATING SCHEDULE" which shall call out the controller program required in order to provide 1.0" of water per week to each planted zone area and 1.5" of water per week to each

University of South Carolina
McKissick Brick Repairs

turf zone area.

4. A typewritten description of the procedures to be followed for proper winterization of the entire system.
- C. Contractor shall be responsible for the first year's winterization and subsequent spring start-up procedures and shall perform these operations in the presence of the Owner's Representative's personnel.

3.15 CLEAN-UP:

- A. Upon completion of the work and before acceptance and final payment will be made, the Landscape Contractor shall make any necessary repairs, adjustments and corrections to the work as required by the Drawings and Specifications. The Landscape Contractor shall remove from the site all machinery, equipment, surplus and discarded materials, rubbish, temporary structures and all other items not incorporated into the work. The site shall be left in a neat and presentable condition. Any damage to roads buildings, walks, vegetation, utilities or any other item of personal property which is the responsibility of the Landscape Contractor, through accident, negligence or normal usage, shall be satisfactorily repaired or replaced as a requirement for completion of this contract.

3.16 GUARANTEE:

- A. For a period of one year from date of final acceptance of the work performed under this Contract, the Landscape Contractor shall promptly furnish, without cost to the Owner, any and all parts and labor which prove defective in material, workmanship, or proper functioning of system.

3.17 REPLACEMENTS:

- A. Landscape Irrigation System - During the last month of the guarantee period, the Landscape Architect and Landscape Contractor shall inspect the installation to determine the condition of the complete system. A list of defective materials or installations to be replaced shall be made by the Landscape Contractor within thirty days of receiving written notification. Replaced materials and installation shall be in accord with these Specifications, Drawings and/or schedules.

END OF SECTION