



PRELIMINARY - NOT FOR CONSTRUCTION

ISSUE DATE:	APRIL 7, 2017	
PHASE:	CONSTRUCTION DOCUMENTS	
#	DATE	REVISION

FLOOR PLAN - LEVEL 100

FINISH SCHEDULE CONCESSIONS																
NO.	WT NAME	FINISHES			NORTH WALL		EAST WALL		SOUTH WALL		WEST WALL		CEILING		REMARKS	
		FLOOR	BASE	MATL.	MATL.	FINISH	MATL.	FINISH	MATL.	FINISH	MATL.	FINISH	MATL.	FINISH		
LEVEL 01																
10	ELECTRICAL	EXISTING	RB	MR	GWB	PT	MR	GWB	PT	MR	GWB	PT	EXISTING	PT	EXPOSED/ PT	
11	MEN	EXISTING/ EPOXY AT NEW	FRP	EXISTING	---	EXISTING/ MR	GWB	PT/FRP	MR	GWB	PT/FRP	EXISTING	PT	EXISTING		
12	WOMEN	EXISTING	EXISTING	---	---	EXISTING	---	---	---	---	---	EXISTING/MR	GWB	PT/FRP	EXISTING	
13	PREP KITCHEN	EPOXY	RB	MR	GWB	PT	MR	GWB	PT	MR	GWB	PT	MR	GWB	PT	ACT 1
14	CONCESSIONS	EPOXY	RB	MR	GWB	PT/FRP	MR	GWB	PT/FRP	MR	GWB	PT/FRP	MR	GWB	PT/FRP	ACT 1
15	ATHLETICS STORAGE	EXISTING	RB	MR	GWB	PT	MR	GWB	PT	MR	GWB	PT	MR	GWB	PT	ACT 1

MR = MOISTURE RESISTANT
FRP = FIBERGLASS REINFORCED PLASTIC PANEL
GWB = GYPSUM WALLBOARD

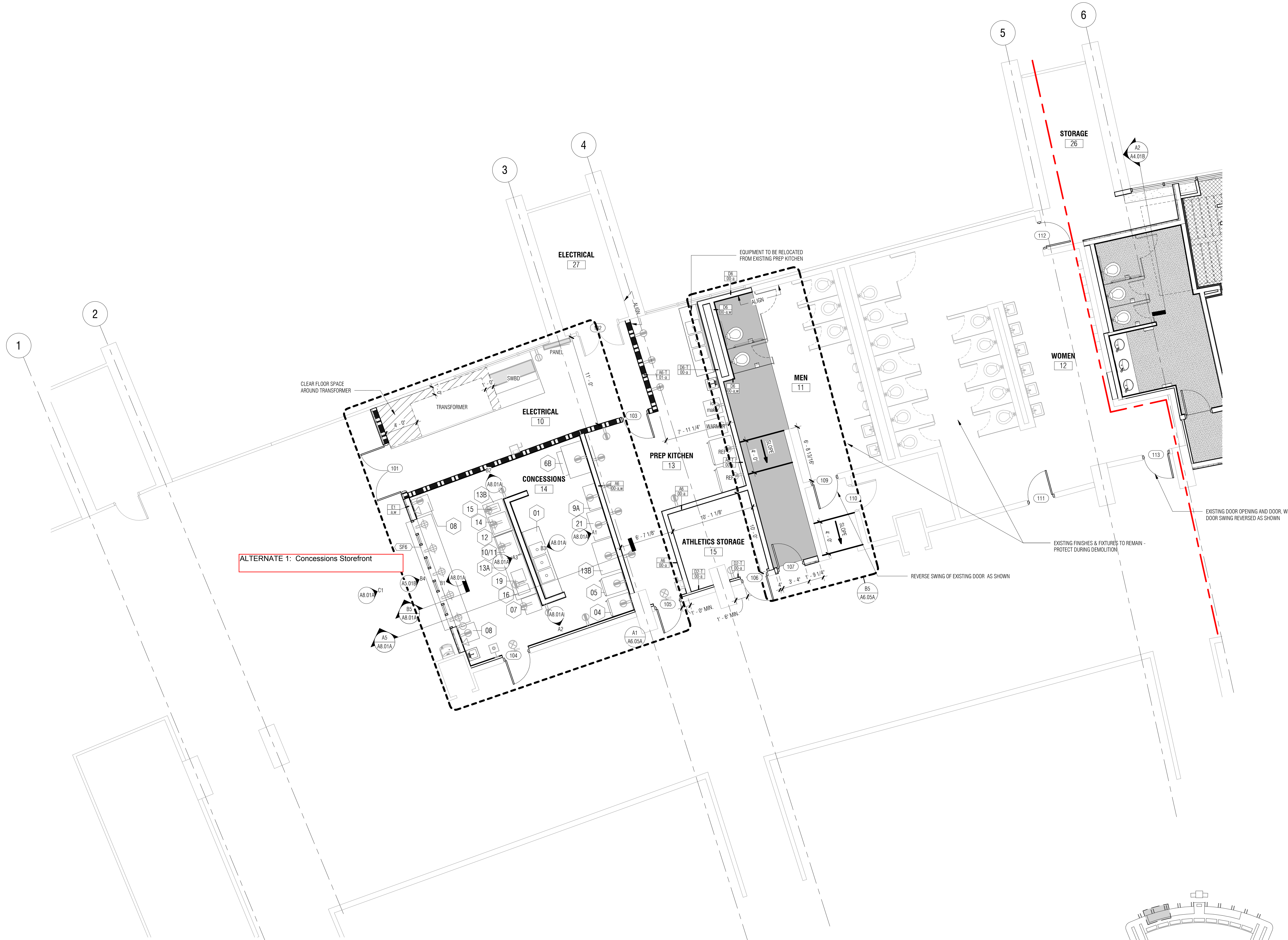

ALTERNATE 1: Concessions Storefront

CONCESSIONS EQUIPMENT

- 1 THREE COMPARTMENT STAINLESS STEEL SINK
- 2 MOP FLOOR SINK
- 3 HAND WASH SINK, STAINLESS STEEL
- 4 REACH-IN SINGLE DOOR COOLER (SUPPLIED BY OTHERS)
- 5 REACH-IN SINGLE DOOR FREEZER (SUPPLIED BY OTHERS)
- 6A ICE MACHINE (SUPPLIED BY OTHERS)
- 6B ICE STORAGE BIN (SUPPLIED BY OTHERS)
- 6C ICE MACHINE FILTRATION SYSTEM (SUPPLIED BY OTHERS)
- 7 1 DOOR TALL GLASS REFRIGERATOR (FOR DRINKS) (SUPPLIED BY OTHERS)
- 8 FOUNTAIN DRINK DISPENSER & DROP-IN STAND (SUPPLIED BY OTHERS)
- 9A FOUNTAIN DRINK BOX AND BAG DISPENSER SYSTEM (SUPPLIED BY OTHERS)
- 9B FOUNTAIN DRINK DISPENSER SYSTEM, PVC ROUTED ABOVE CEILING (SUPPLIED BY OTHERS)
- 10 HOT DOG "GRILLE" ROLLER (STACKED ON BUN WARMER) (SUPPLIED BY OTHERS)
- 11 BUN WARMER (UNDER HOT DOG ROLLER) (SUPPLIED BY OTHERS)
- 12 LOW STAINLESS STEEL TABLE (300 X 36W X 18H) (SUPPLIED BY OTHERS)
- 13A STAINLESS STEEL TABLE (300 X 60W X 36H) (SUPPLIED BY OTHERS)
- 13B STAINLESS STEEL TABLE (300 X 48W X 36H) (SUPPLIED BY OTHERS)
- 14 POPCORN MAKER (SUPPLIED BY OTHERS)
- 15 CHILI MACHINE (SUPPLIED BY OTHERS)
- 16 NACHO - CHEESE MACHINE (SUPPLIED BY OTHERS)
- 17 CANDY DISPLAY RACK (SUPPLIED BY OTHERS)
- 18 AIR CURTAINS (TOTAL OF 5, 1 AT EACH WINDOW)
- 19 PRETZEL MACHINE (SUPPLIED BY OTHERS)
- 20 BACK-LIT MENU BOARD / SIGNAGE
- 21 METAL MESH SHELVING (SUPPLIED BY OTHERS)
- 22 STAINLESS STEEL SHELF WALL MOUNTED (SUPPLIED BY OTHERS)

FLOOR PLAN - LEVEL 100
3/16" = 1'-0"

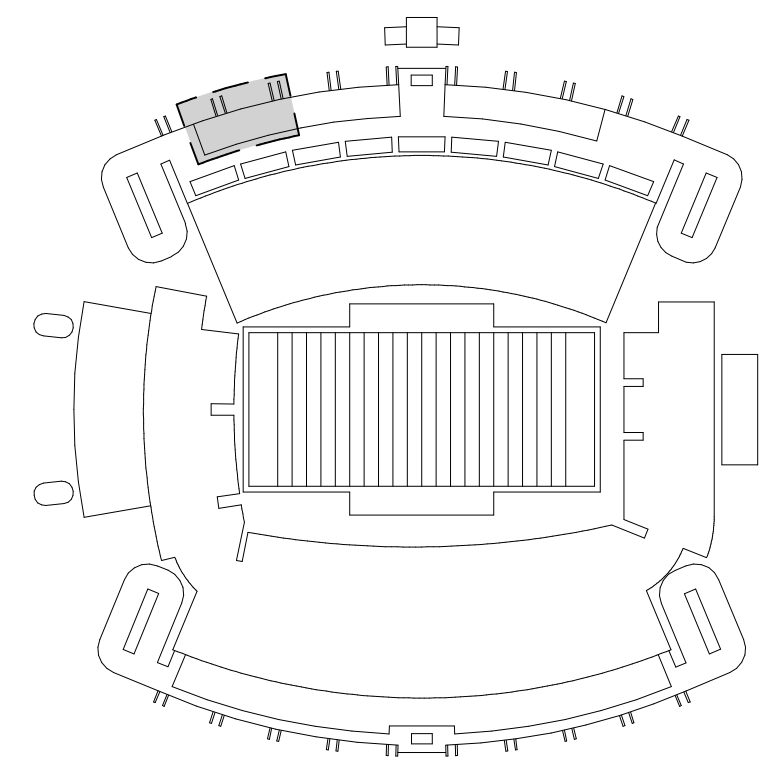
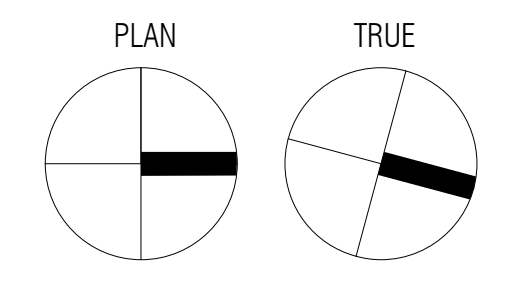

4/7/2017 2:41:19 PM C:\Users\jgall\Documents\1701_WBS_Renovations_A11_2_gbl.rvt
 These drawings are the property of Watson Tate Savory, Inc. and may not be used in whole or in part without written consent of the architect and any infringement is subject to legal action.

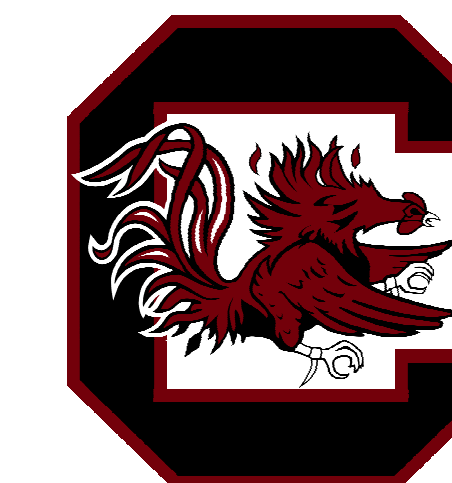

PRELIMINARY - NOT FOR CONSTRUCTION

ISSUE DATE: APRIL 7, 2017
PHASE: CONSTRUCTION DOCUMENTS

#	DATE	REVISION

FLOOR PLANS -
LEVELS 100 & 200

STATE PROJECT NO. **A1.01B**
1702
WTS PROJECT NO. SHEET

FINISH SCHEDULE ENTERTAINMENT SUITE														
NO.	ROOM NAME	FINISHES		NORTH WALL		EAST WALL		SOUTH WALL		WEST WALL		CEILING		REMARKS
		FLOOR	BASE	MATL.	FINISH	MATL.	FINISH	MATL.	FINISH	MATL.	FINISH	MATL.	FINISH	
LEVEL 01														
16	WOMEN													
20	ENTERTAINMENT SUITE													
21	MEN													
24	ELECTRICAL													
25	ELECTRICAL/HVAC													
26	STORAGE													
27	ELECTRICAL	EXISTING		EXISTING		EXISTING		EXISTING		EXISTING			EXISTING	
29	TELECOM													
30	CORRIDOR													
207D	COAT CLOSET													
207F	CORRIDOR													
LEVEL 02														
207	CLUB LOUNGE													
207A	WOMEN													
207B	MEN													
207C	ELEC													

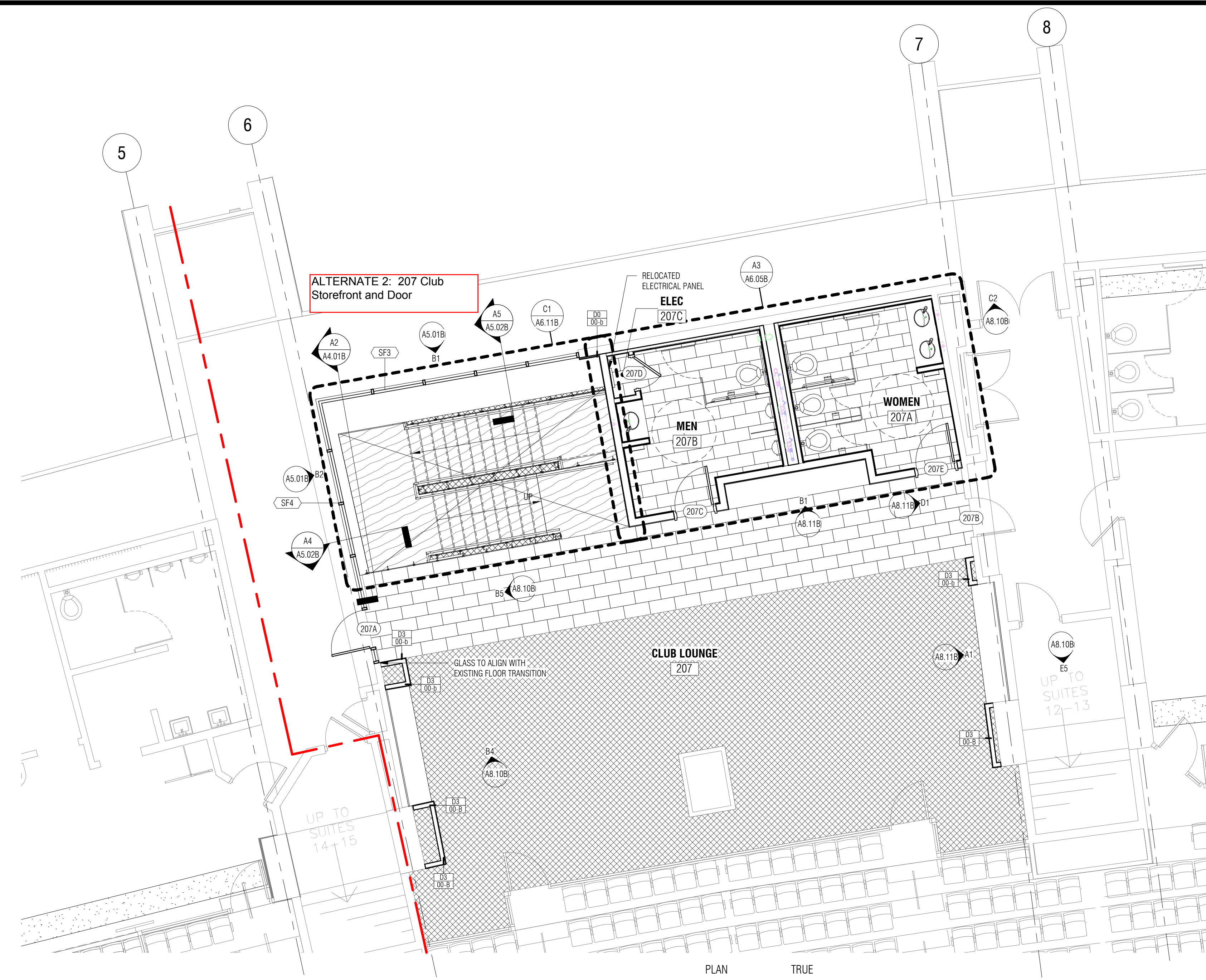

FLOOR PLAN - LEVEL 200
3/16" = 1'-0"

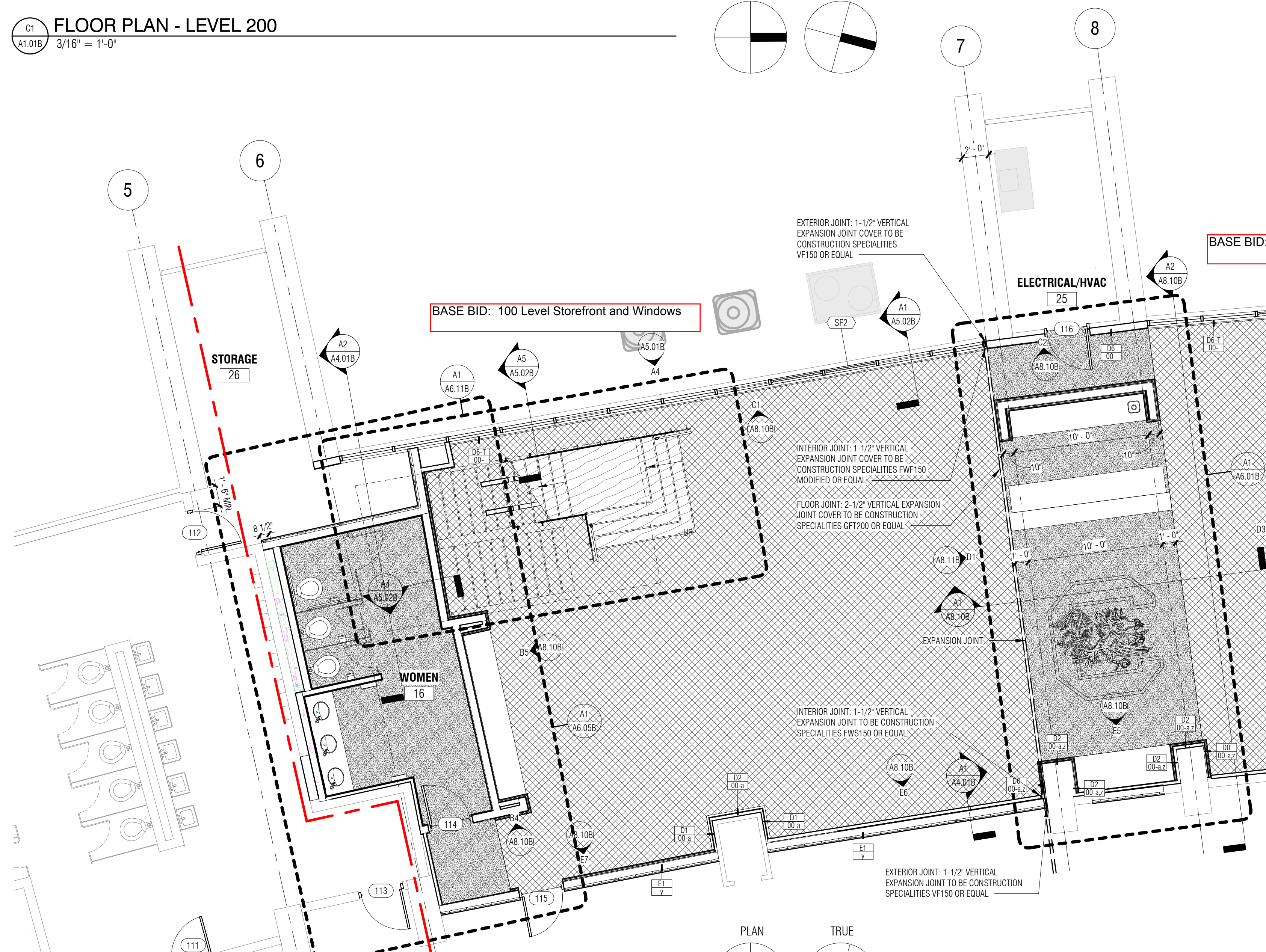

FLOOR PLAN - LEVEL 100
3/16" = 1'-0"

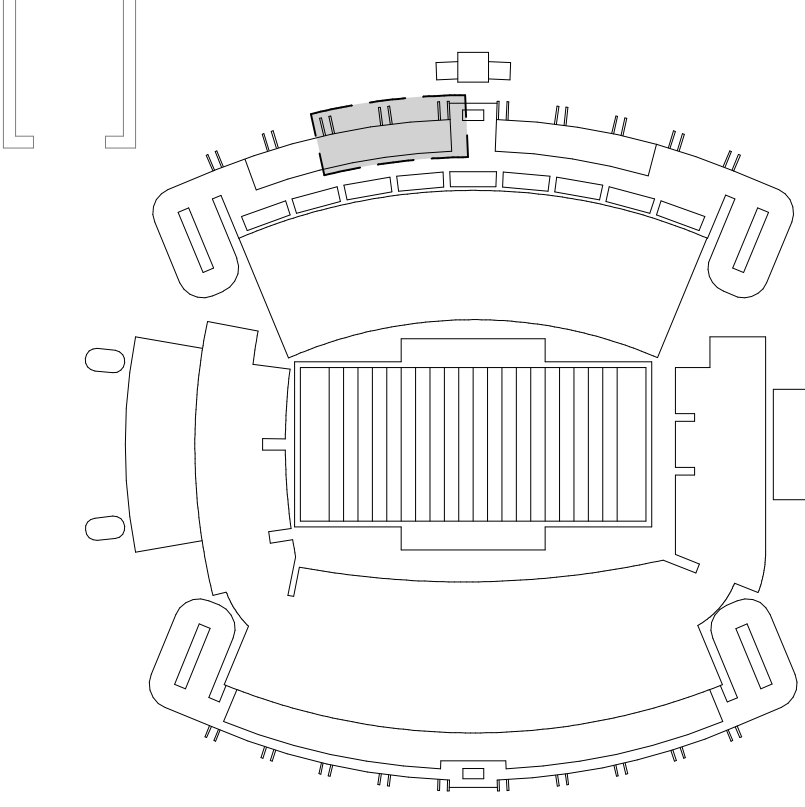

4/7/2017 2:44:25 PM C:\Users\jball\Documents\100_WBS Renovations_A1_2_gball.rvt



PRELIMINARY - NOT FOR CONSTRUCTION

ISSUE DATE: APRIL 7, 2017
PHASE: CONSTRUCTION DOCUMENTS

#	DATE	REVISION
2	2016 xxxx	ASI-xxx Description (Optional)

STOREFRONT
ELEVATIONS

4/7/2017 2:44:25 PM C:\Users\ghell\Documents\100_WBS_Renovations_A17_2_ghell.rvt

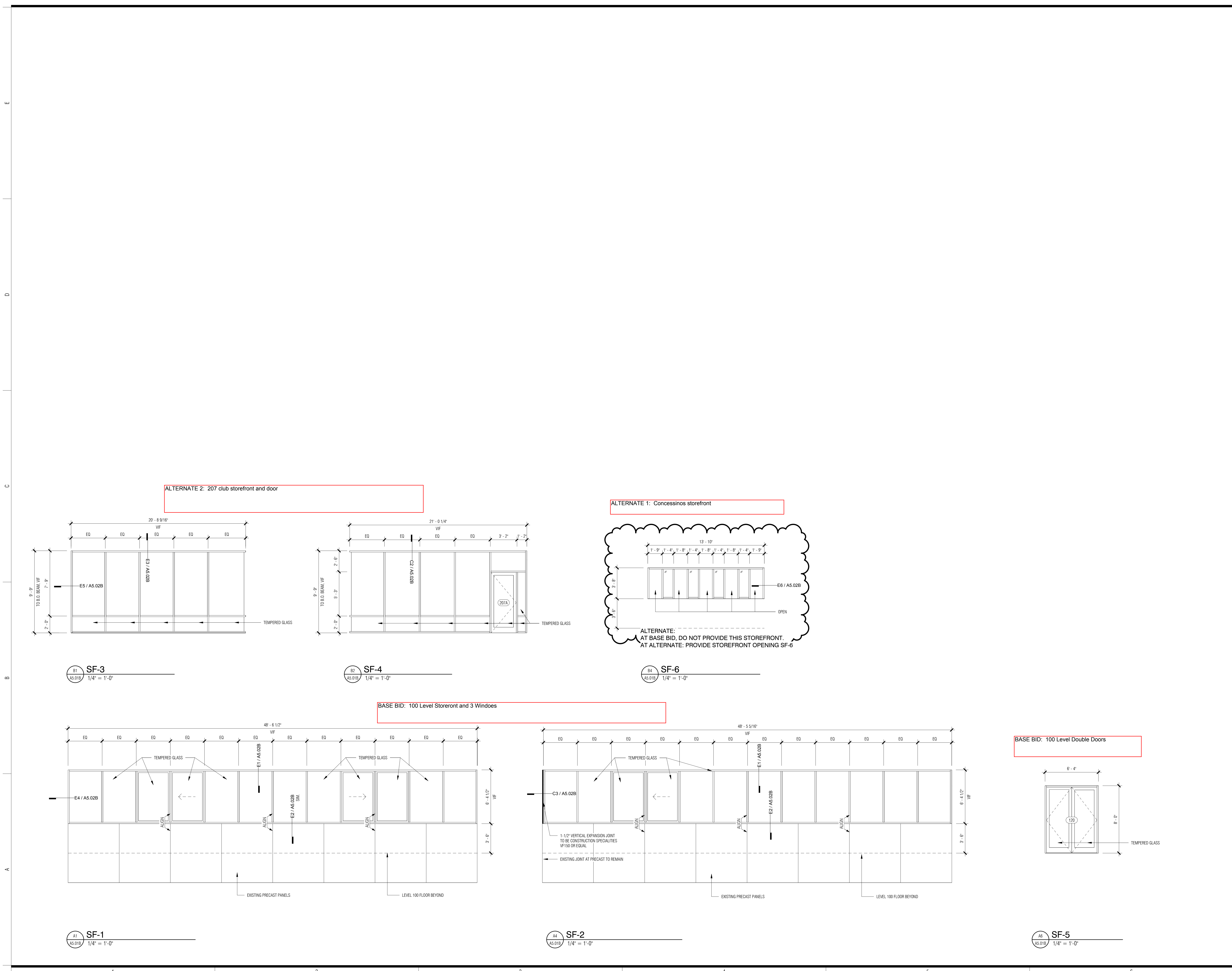

ALTERNATE 2: 207 club storefront and door

ALTERNATE 1: Concessinos storefront

BASE BID: 100 Level Storefront and 3 Windows

BASE BID: 100 Level Double Doors

ALTERNATE:
AT BASE BID, DO NOT PROVIDE THIS STOREFRONT.
AT ALTERNATE: PROVIDE STOREFRONT OPENING SF-6

SF-3
A5.01B 1/4" = 1'-0"

SF-4
A5.01B 1/4" = 1'-0"

SF-6
A5.01B 1/4" = 1'-0"

SF-1
A5.01B 1/4" = 1'-0"

SF-2
A5.01B 1/4" = 1'-0"

SF-5
A5.01B 1/4" = 1'-0"



PRELIMINARY - NOT FOR CONSTRUCTION

ISSUE DATE: APRIL 7, 2017
PHASE: CONSTRUCTION DOCUMENTS

#	DATE	REVISION

STOREFRONT
SECTIONS &
DETAILS

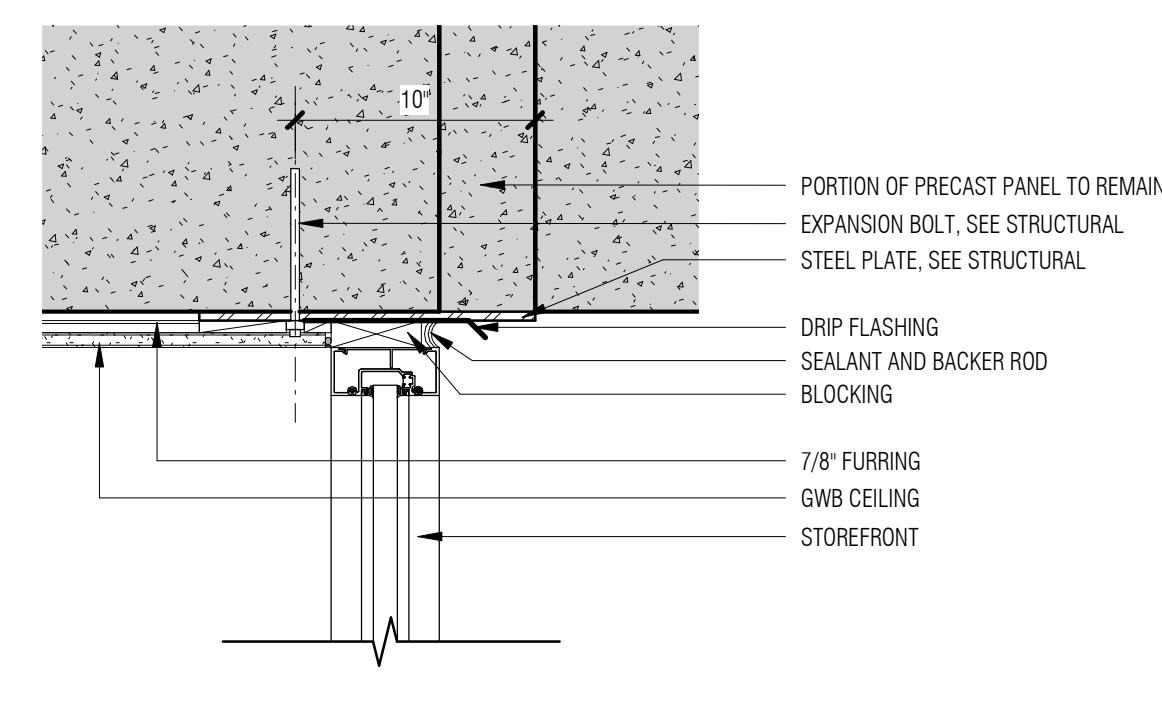

E1 SF HEAD DETAIL
A5.02B 1 1/2" = 1'-0"

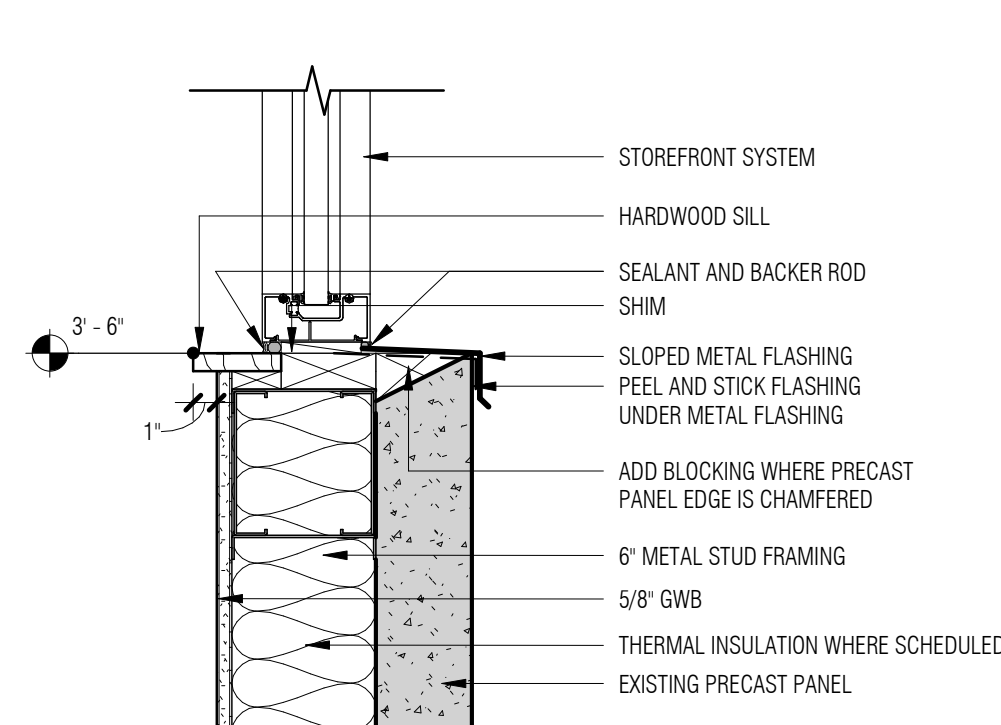

E2 SF SILL DETAIL
A5.02B 1 1/2" = 1'-0"

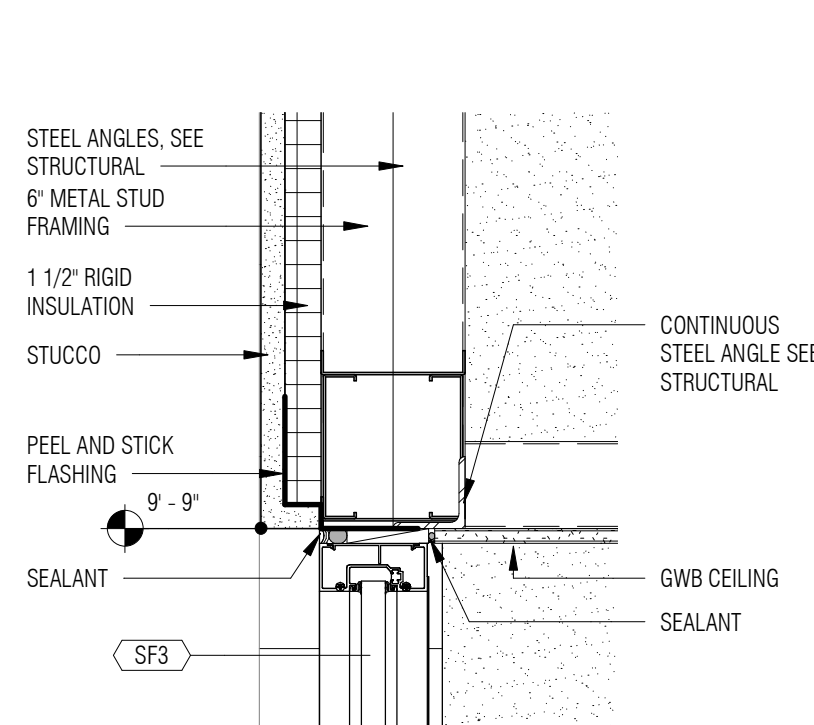

E3 SF HEAD DETAIL
A5.02B 1 1/2" = 1'-0"

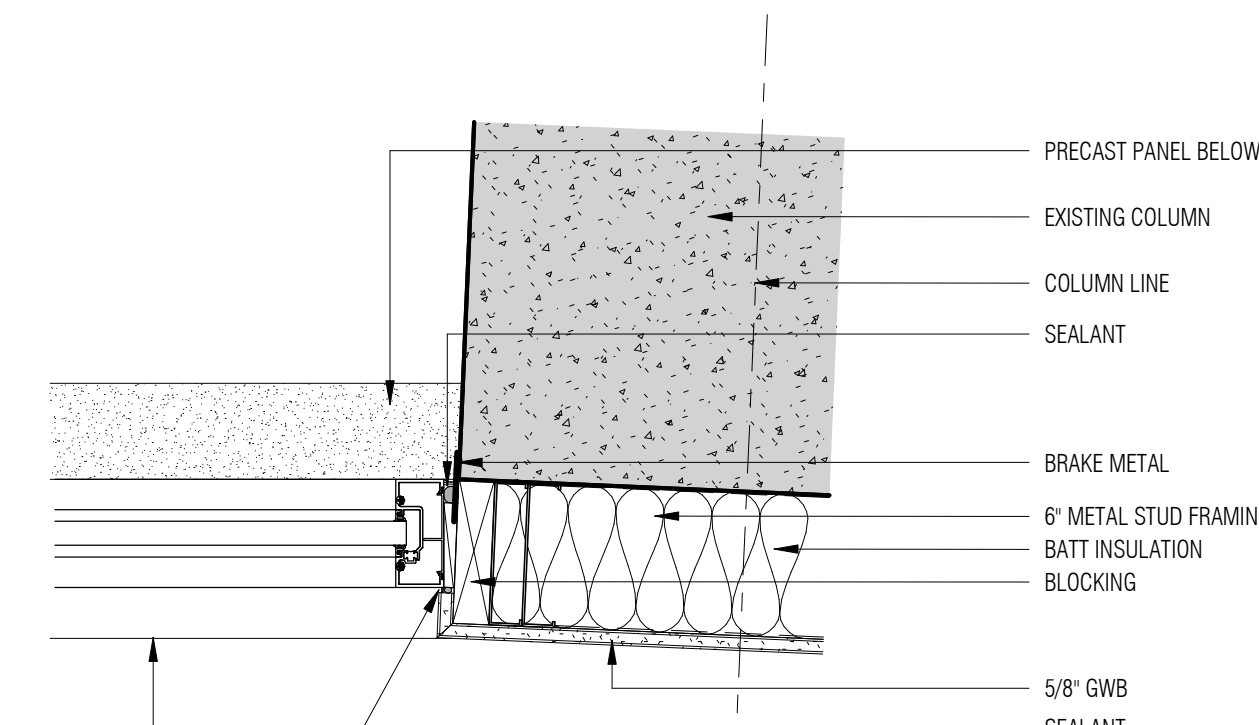

E4 JAMB DETAIL
A5.02B 1 1/2" = 1'-0"

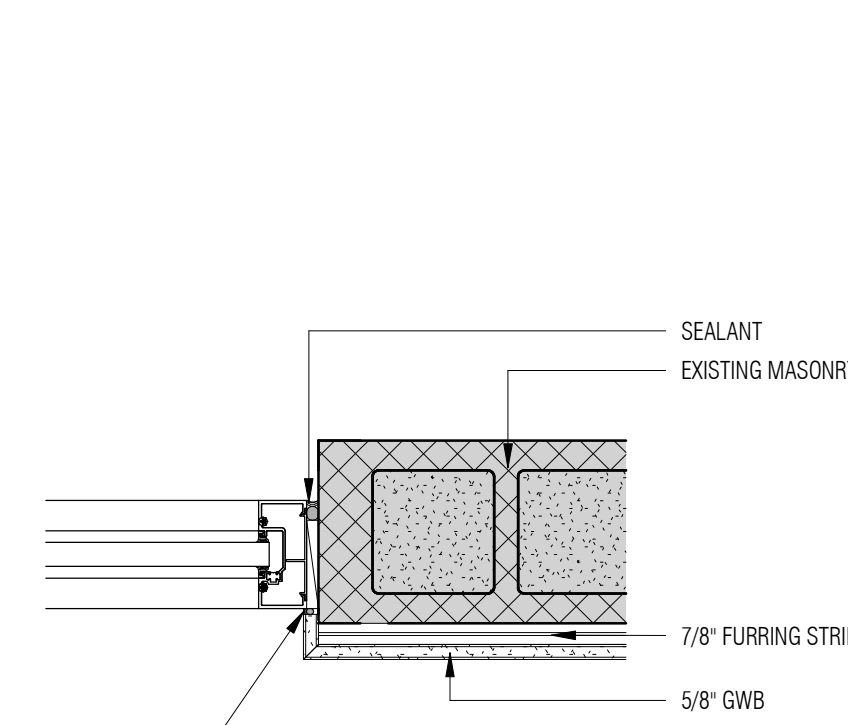

E5 SF JAMB DETAIL
A5.02B 1 1/2" = 1'-0"

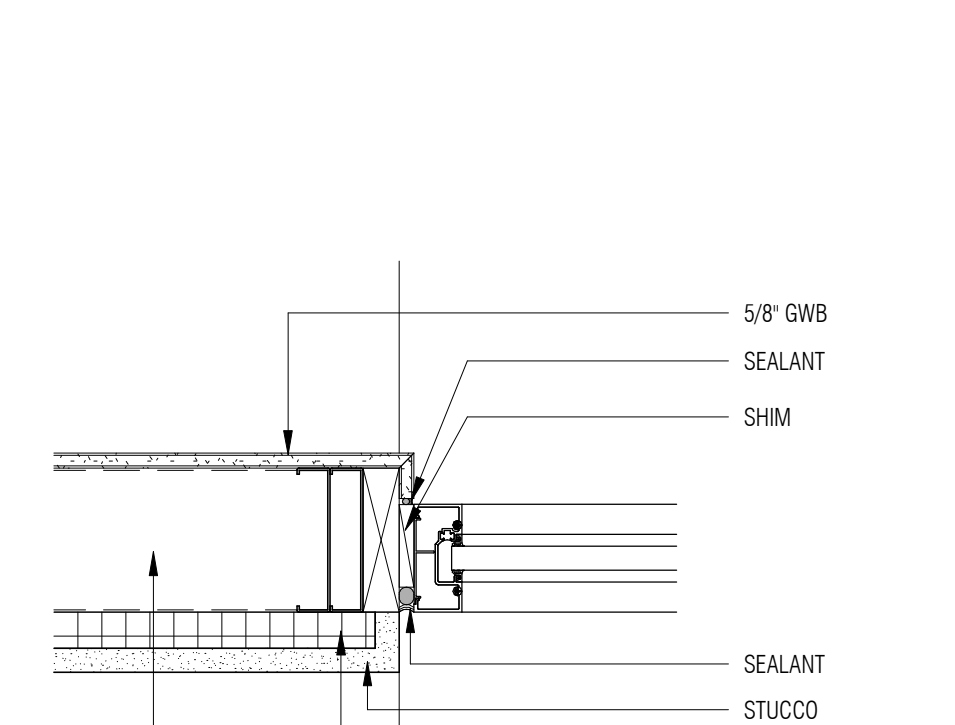

E6 SF JAMB DETAIL
A5.02B 1 1/2" = 1'-0"

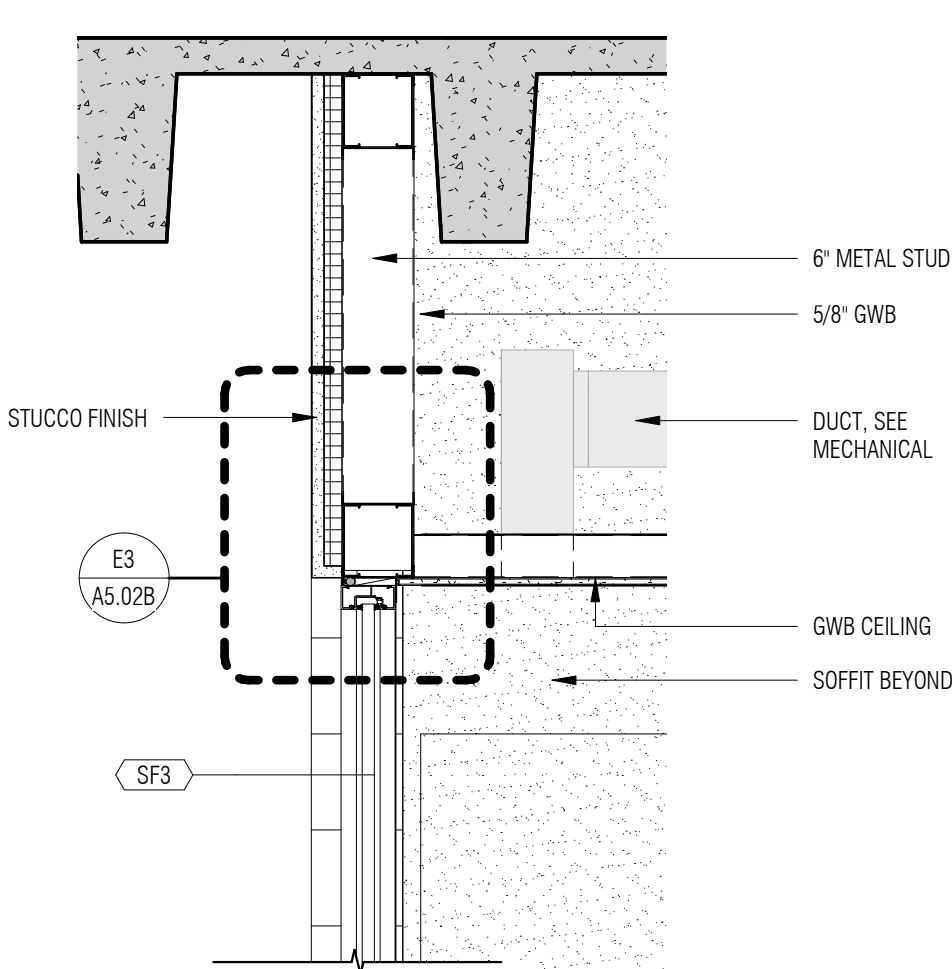

C1 CEILING DETAIL
A5.02B 3/4" = 1'-0"

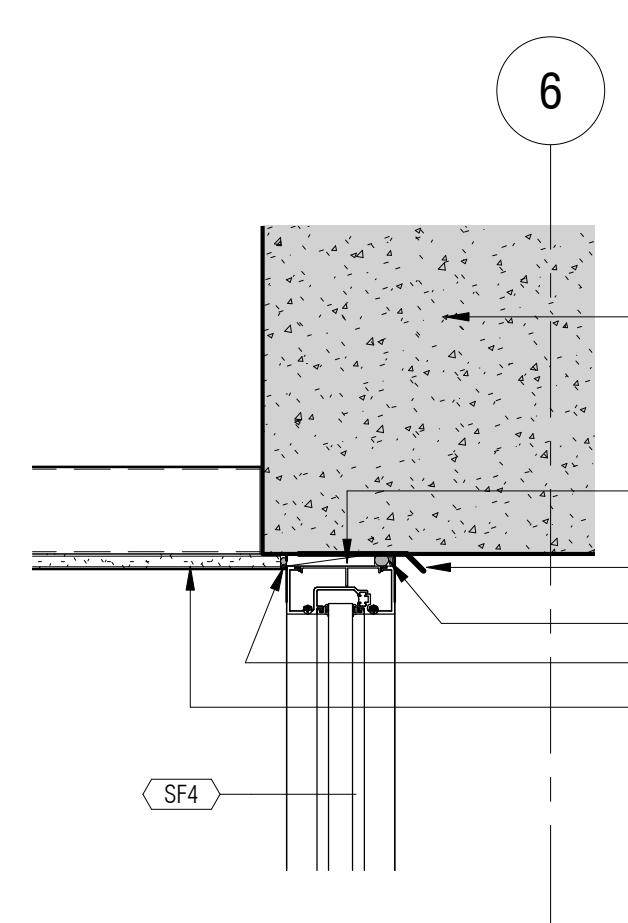

C2 SF HEAD DETAIL
A5.02B 1 1/2" = 1'-0"

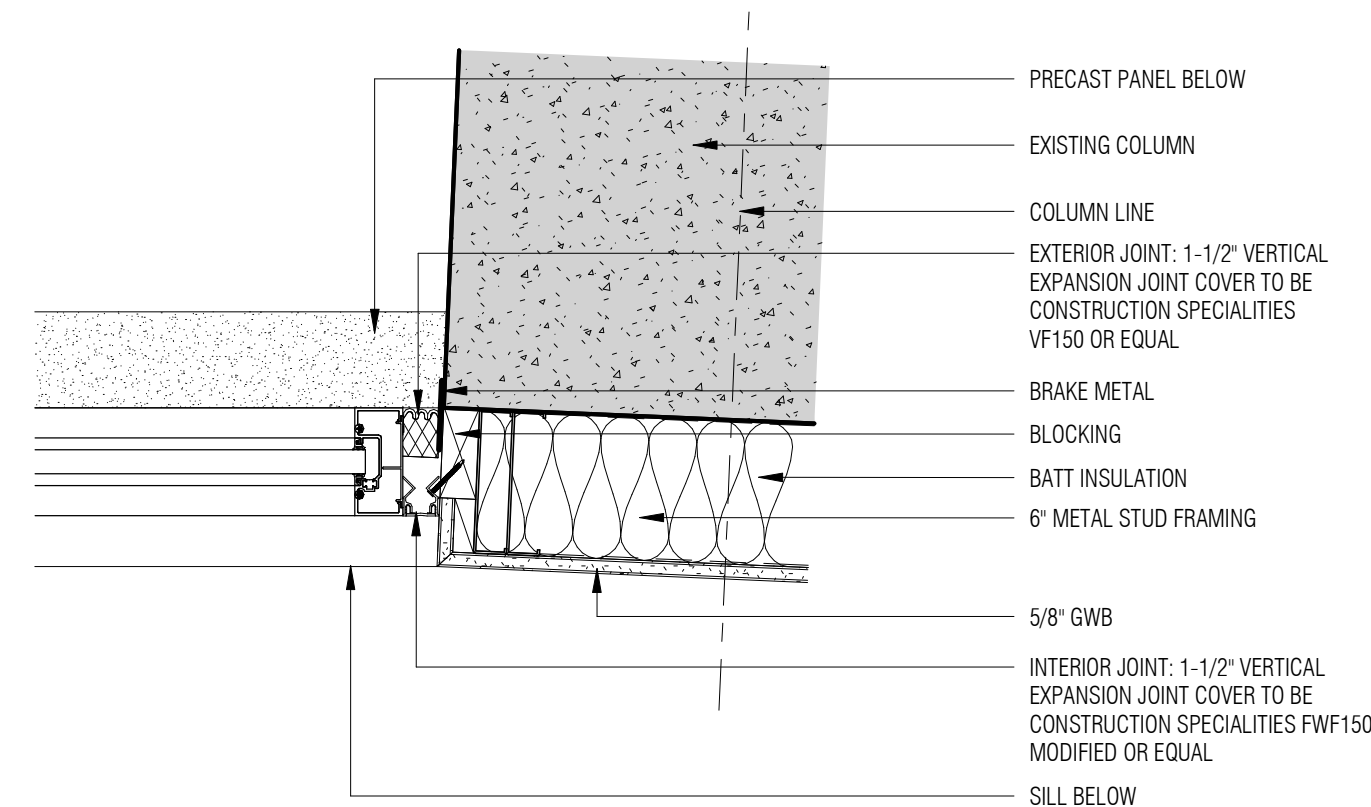

C3 SF JAMB DETAIL
A5.02B 1 1/2" = 1'-0"

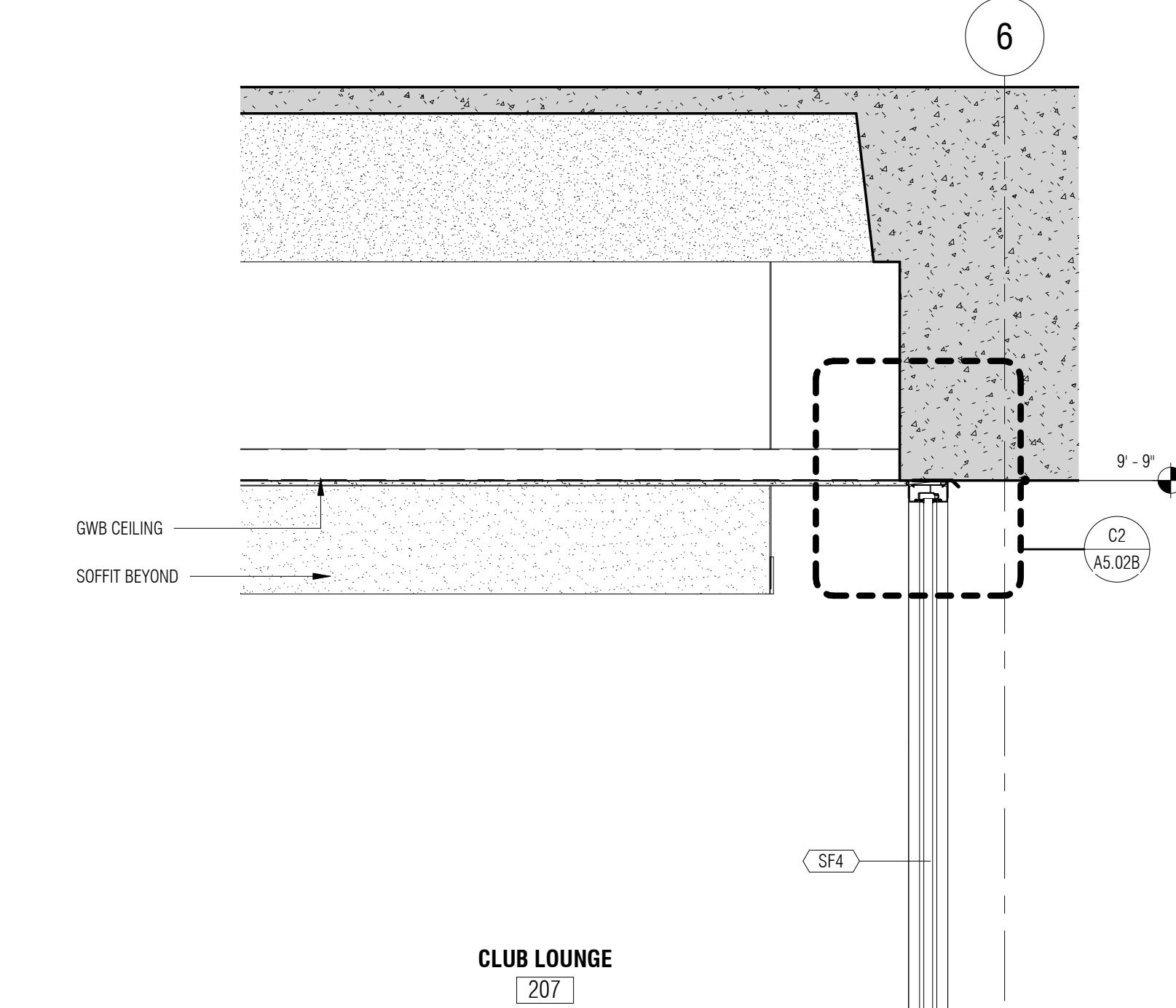

A4 STOREFRONT SECTION
A5.02B 3/4" = 1'-0"

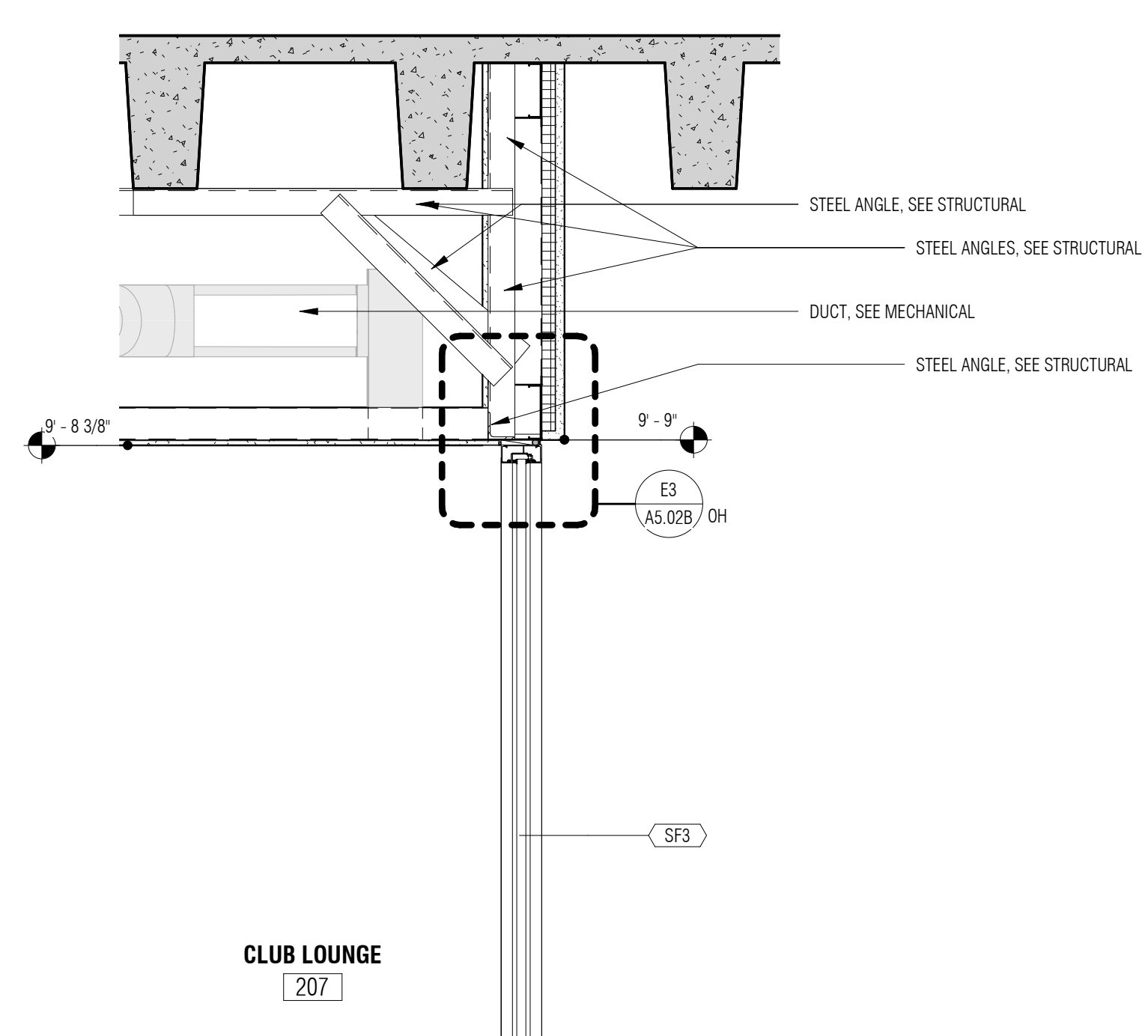

A5 STOREFRONT SECTION
A5.02B 3/4" = 1'-0"

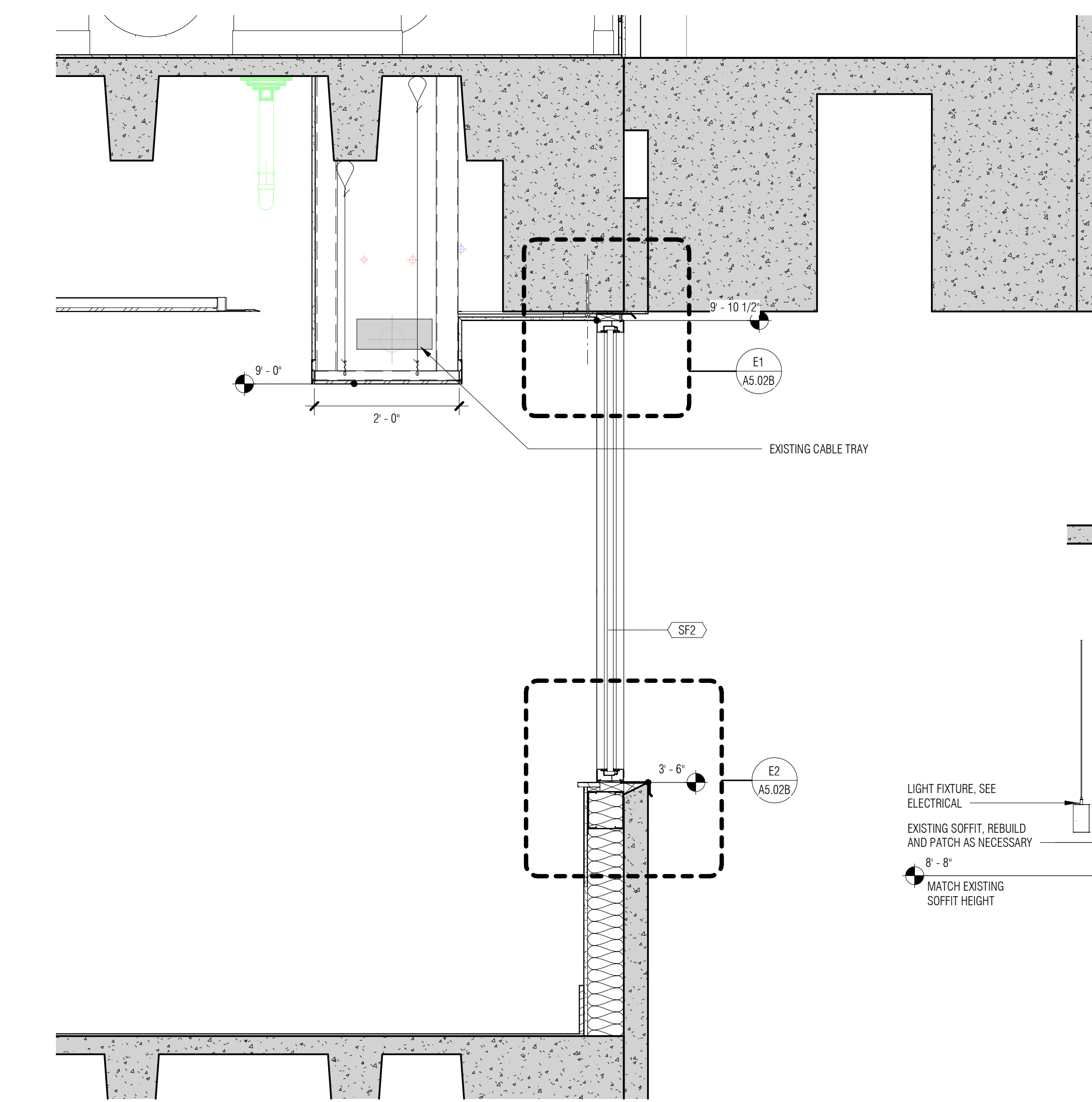

A1 STOREFRONT SECTION
A5.02B 3/4" = 1'-0"

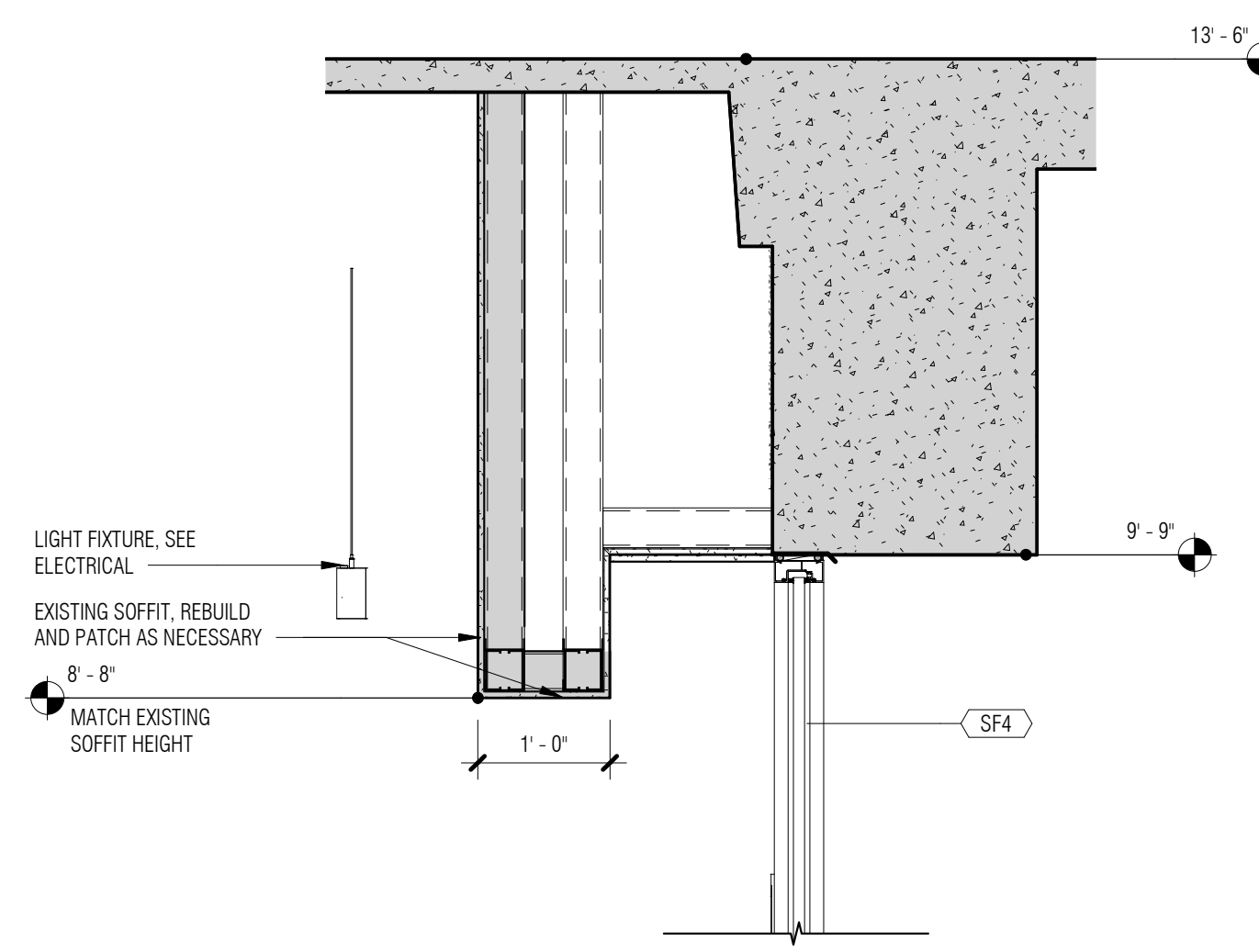

A2 CEILING DETAIL
A5.02B 3/4" = 1'-0"

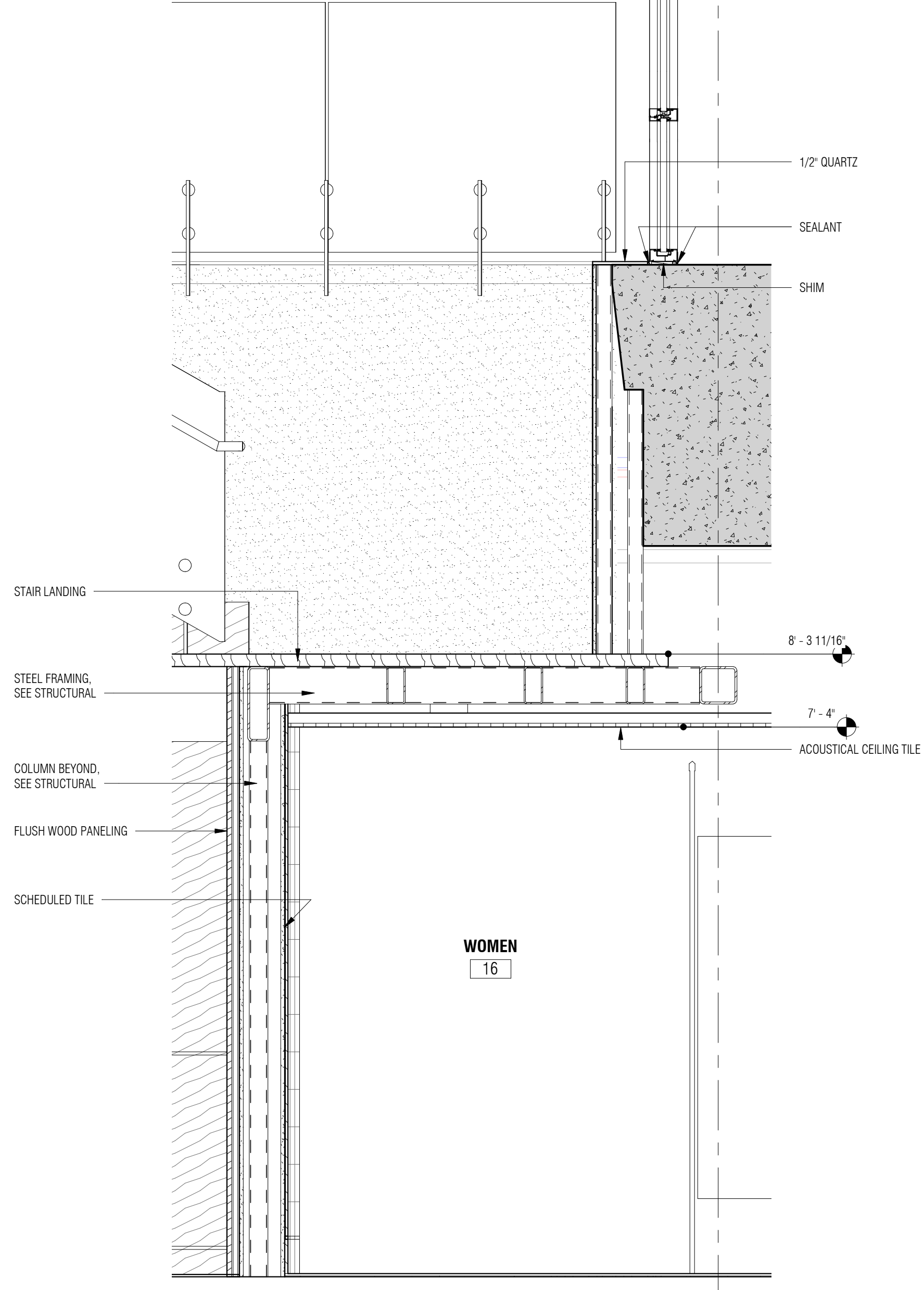

A3 STOREFRONT SECTION
A5.02B 3/4" = 1'-0"

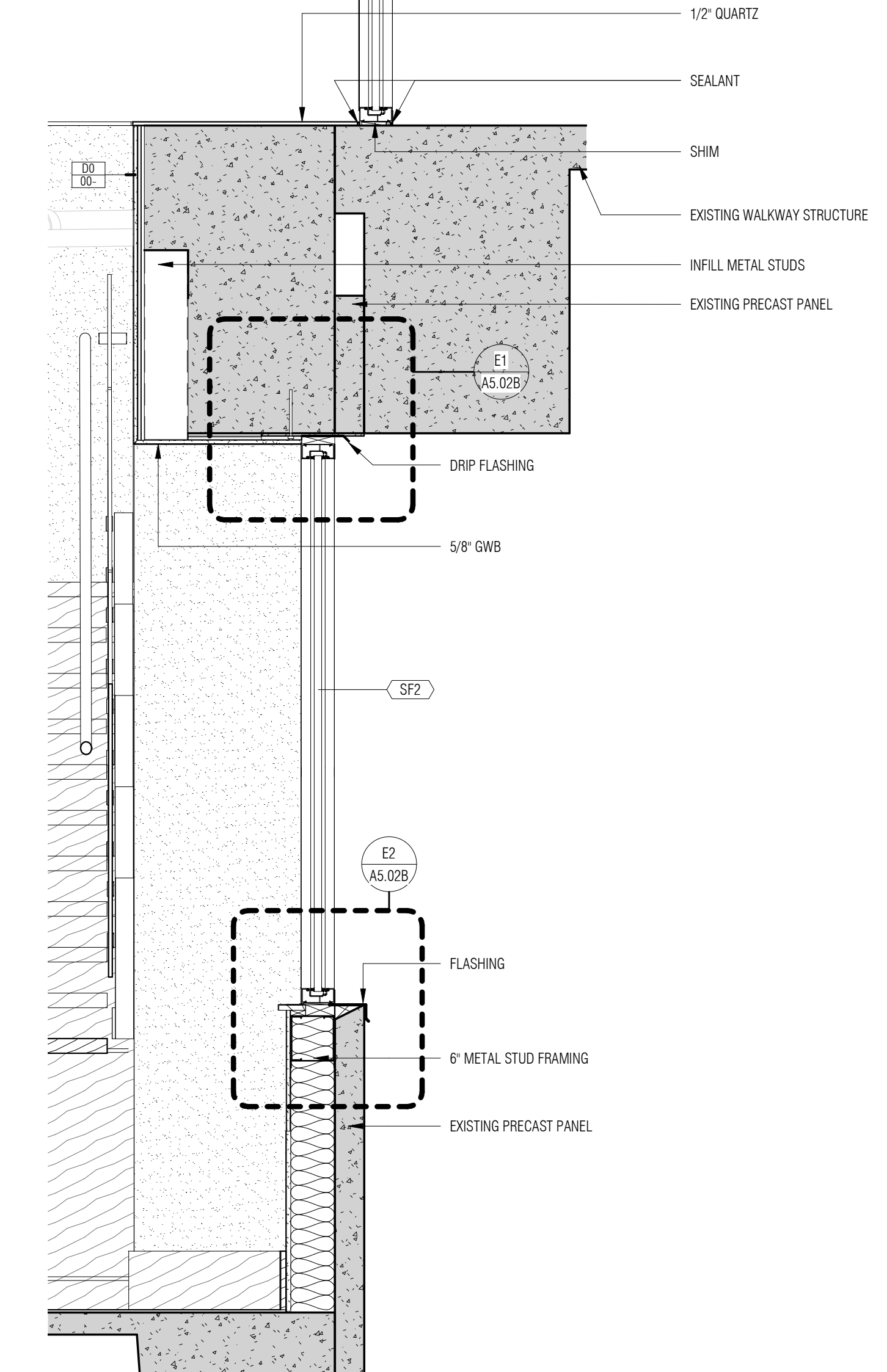

A6 STOREFRONT SECTION
A5.02B 3/4" = 1'-0"

These drawings are the property of Watson Tate Savory, Inc. and may not be used in whole or in part without written consent of the architect and any infringement is subject to legal action.

C:\Users\ghall\Documents\100_WBS_Renovations_A17_2_gball.rvt 4/7/2017 2:44:27 PM



PRELIMINARY - NOT FOR CONSTRUCTION

ISSUE DATE:	APRIL 7, 2017	
PHASE:	CONSTRUCTION DOCUMENTS	
#	DATE	REVISION

ENLARGED PLANS
& ELEVATIONS

TOILET ACCESSORIES				
NO.	ITEM	MOUNTING HEIGHT	MFG.	MODEL NO.
TA-1	GLASS MIRROR WITH STAINLESS STEEL ANGLE FRAME (20" X 36")		BRADLEY	B-290 Series
TA-2	COUNTER MOUNTED AUTOMATIC SOAP DISPENSER		BOBRICK	B-824
TA-3	36" STAINLESS STL GRAB BAR w/ SATIN FINISH (HORIZONTALLY MOUNTED)		BOBRICK	B-5806 Series
TA-4	42" STAINLESS STL GRAB BAR w/ SATIN FINISH (HORIZONTALLY MOUNTED)		BOBRICK	B-5806 Series
TA-5	18" STAINLESS STL GRAB BAR w/ SATIN FINISH (VERTICALLY MOUNTED)		BOBRICK	B-5806 Series
TA-6	MULTI-ROLL TOILET TISSUE DISPENSER (SURFACE-MOUNTED)		---	FURNISHED BY OWNER
TA-7	SURFACE MOUNTED COMBINATION TOWEL AND WASTE UNIT		BOBRICK	B-3699
TA-8	FACIAL TISSUE DISPENSER		BRADLEY	987-36

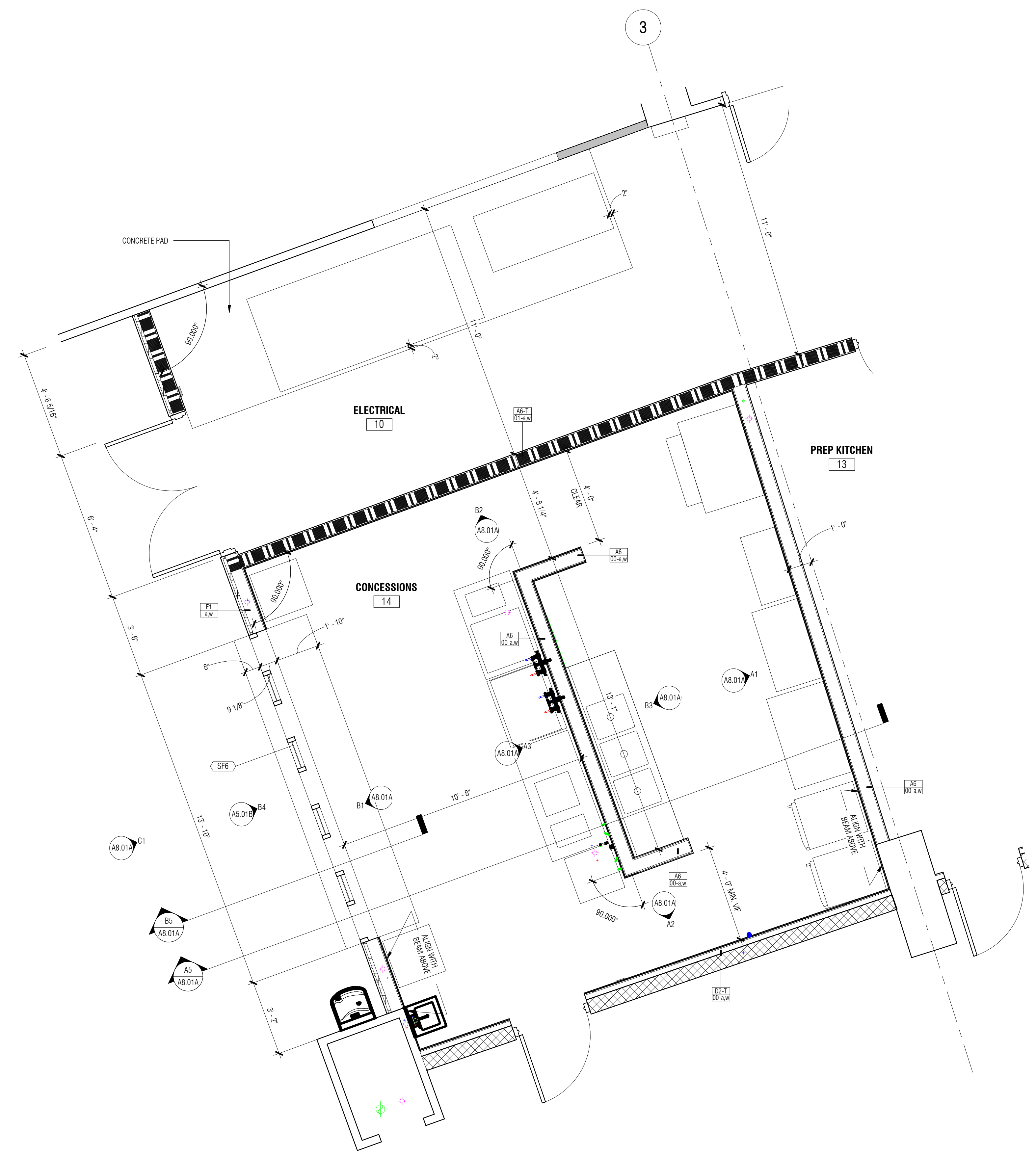

A1 ENLARGED PLAN
A6.05A 3/8" = 1'-0"

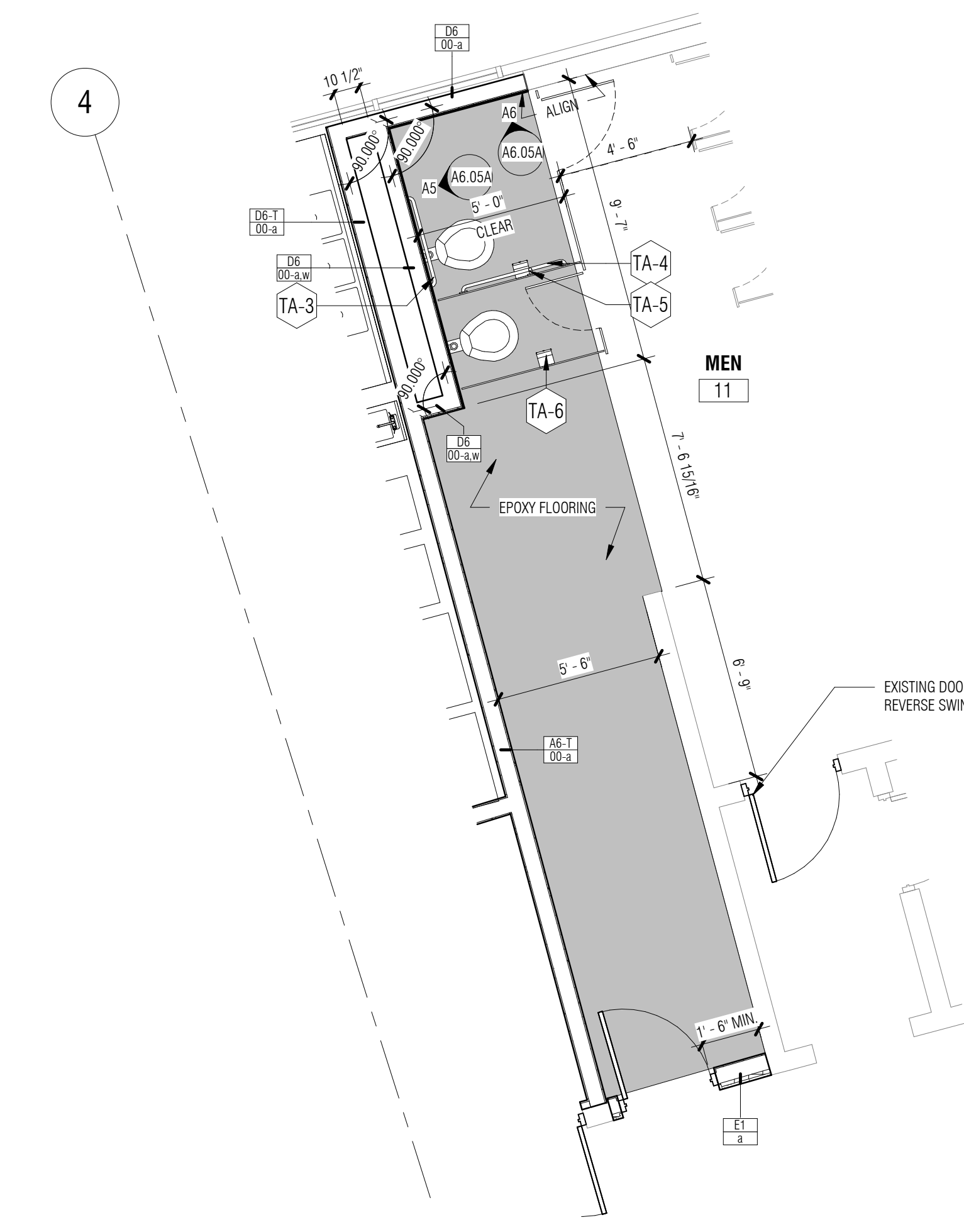

B5 LEVEL 100 MEN'S PUBLIC RESTROOM
A6.05A 1/4" = 1'-0"

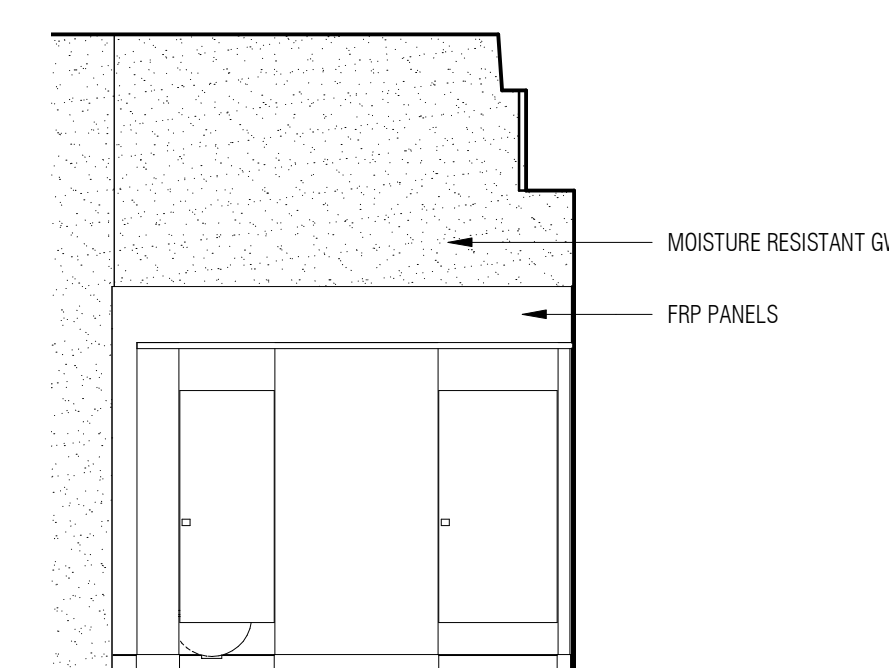

A5 MEN'S PUBLIC RESTROOM
A6.05A 1/4" = 1'-0"

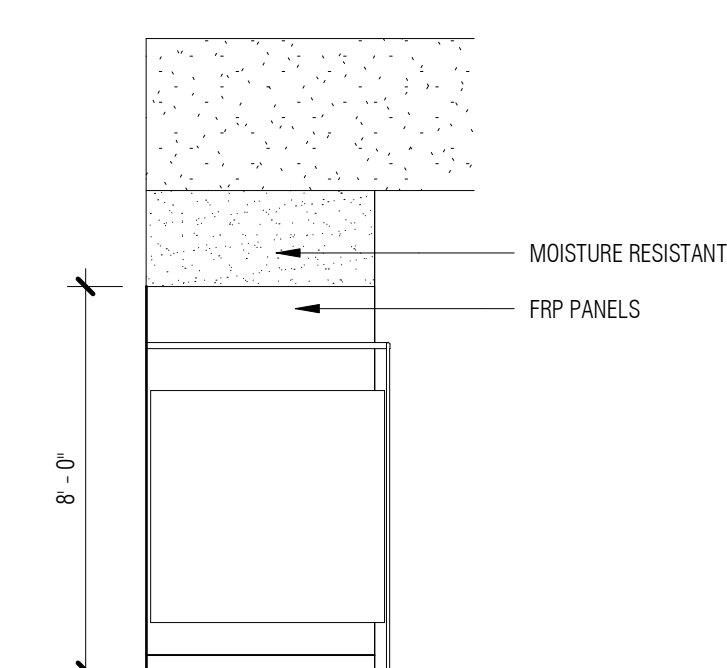

A6 MEN'S PUBLIC RESTROOM
A6.05A 1/4" = 1'-0"

4/7/2017 2:44:28 PM C:\Users\jgall\Documents\100_WBS_Renovations_A17_2_gall.rvt These drawings are the property of Watson T. Savory, Inc. and may not be used in whole or in part without written consent of the architect and any infringement is subject to legal action.