

DODIE ANDERSON ACADEMIC ENRICHMENT CENTER NUTRITION STATION

UNIVERSITY OF SOUTH CAROLINA ATHLETICS

STATE PROJECT NO. H27-Z302

1302 Heyward Street
Columbia SC, 29208

CONSTRUCTION DOCUMENTS

NOVEMBER 4, 2016



ARCHITECTURE
INTERIORS
PLANNING

WTS
WATSON TATE SAVORY



DODIE ANDERSON ACADEMIC ENRICHMENT CENTER
NUTRITION STATION

STATE PROJECT NO. H27-Z302

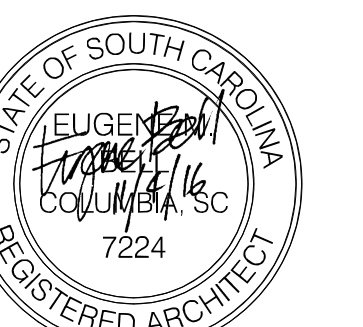

PHASE: CONSTRUCTION DOCUMENTS

| # | DATE | REVISION |
|---|------|----------|
| | | |
| | | |
| | | |
| | | |
| | | |
| | | |
| | | |
| | | |
| | | |
| | | |

TITLE SHEET

NOVEMBER 4, 2016
ISSUE DATE
1627
PROJECT NO. SHEET

T1.00

Owner:
University of South Carolina
743 Greene Street
Columbia, SC 29208
803.777.5500
www.sc.edu

Architect:
Watson Tate Savory, Inc.
1316 Washington Street
Suite 100
Columbia, SC 29201
803.799.5181
www.watsonatesavory.com

Mechanical / Plumbing / Fire Protection:
Mechanical Design, Inc.
4403 Broad River Road
Columbia, SC 29210
803.731.9834

Electrical:
Belka Engineering Assoc.
7 Clusters Court
Suite 201
Columbia, SC 29210
803.731.0650

These drawings are the property of Watson Tate Savory, Inc. and may not be used in whole or in part without written consent of the architect and any infringement is subject to legal action.

C:\Users\jsh\Documents\1006-000-000-Dodie Anderson Nutrition Station_A17.dwg

11/18/2016 10:23:04 AM

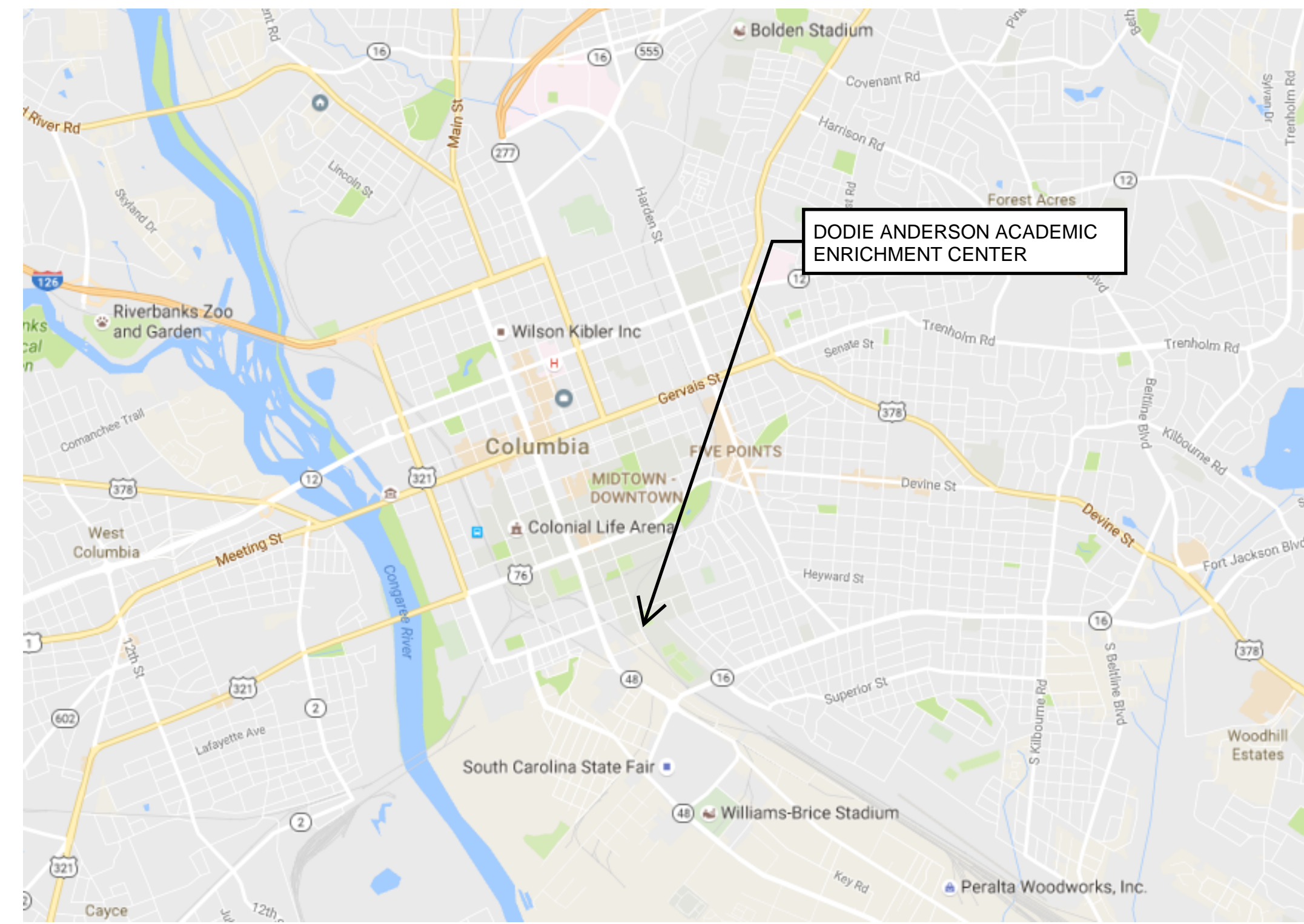

AREA MAP

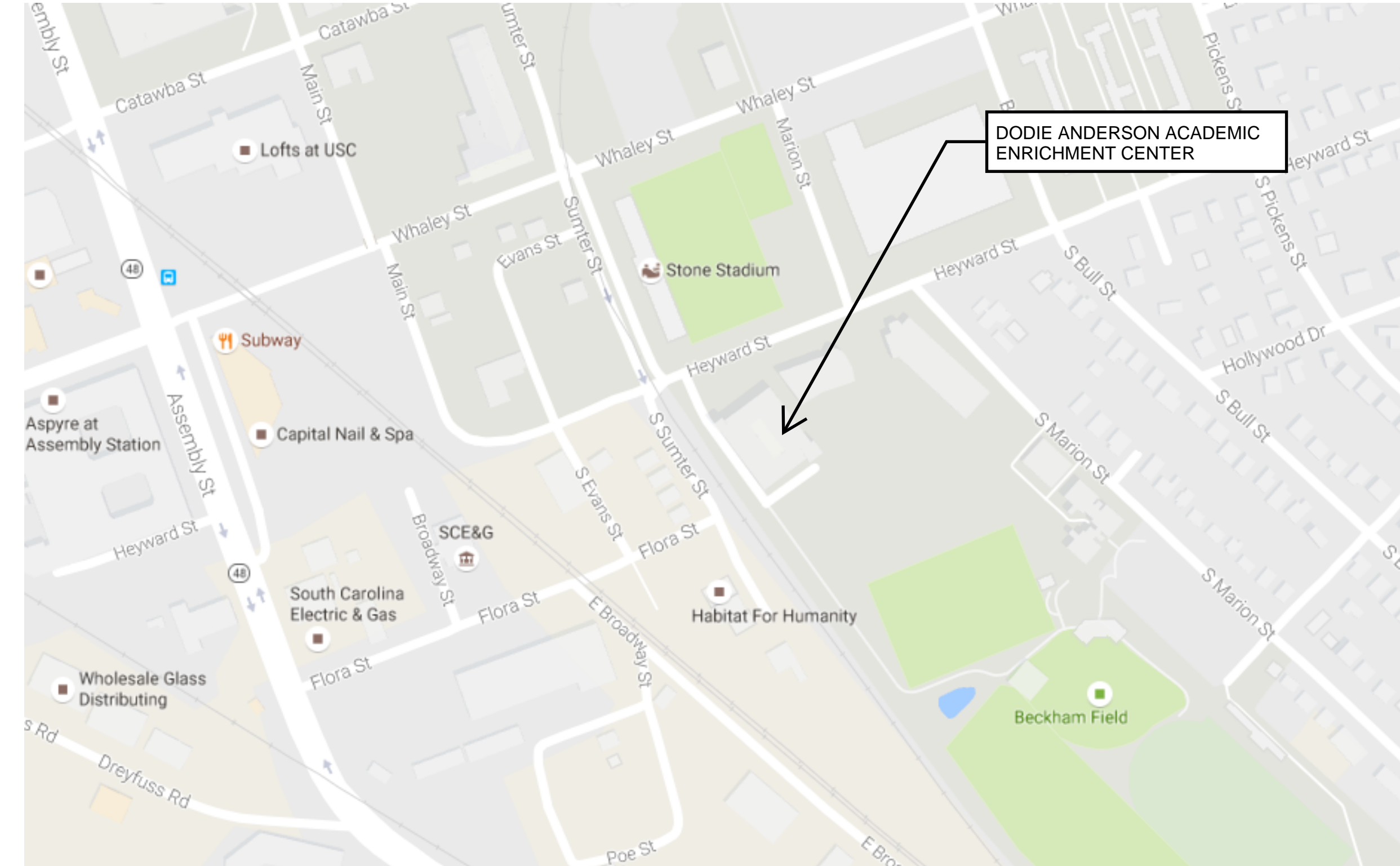

VICINITY MAP

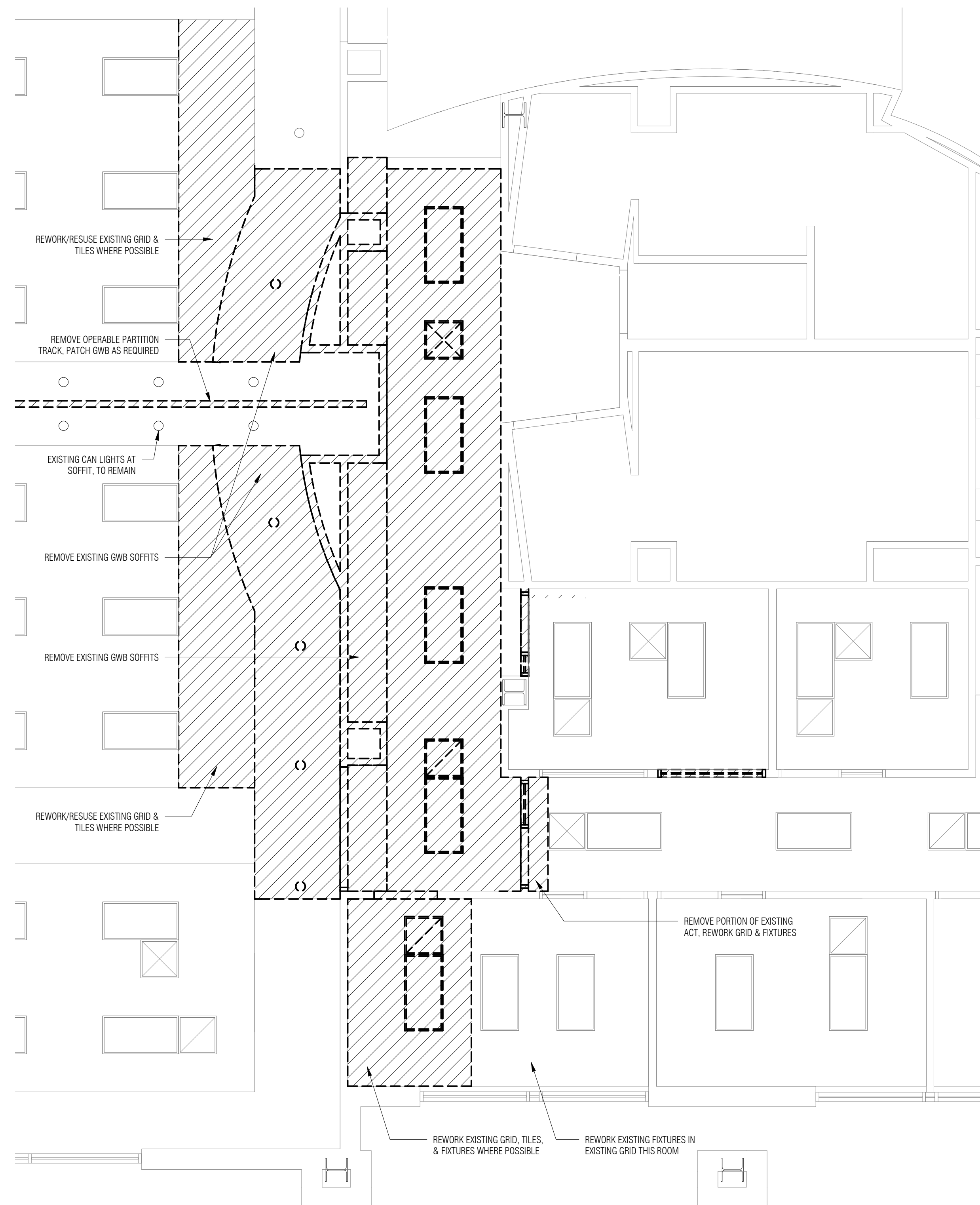

2 DEMOLITION REFLECTED CEILING PLAN - FIRST FLOOR
01.01 1/4" = 1'-0"

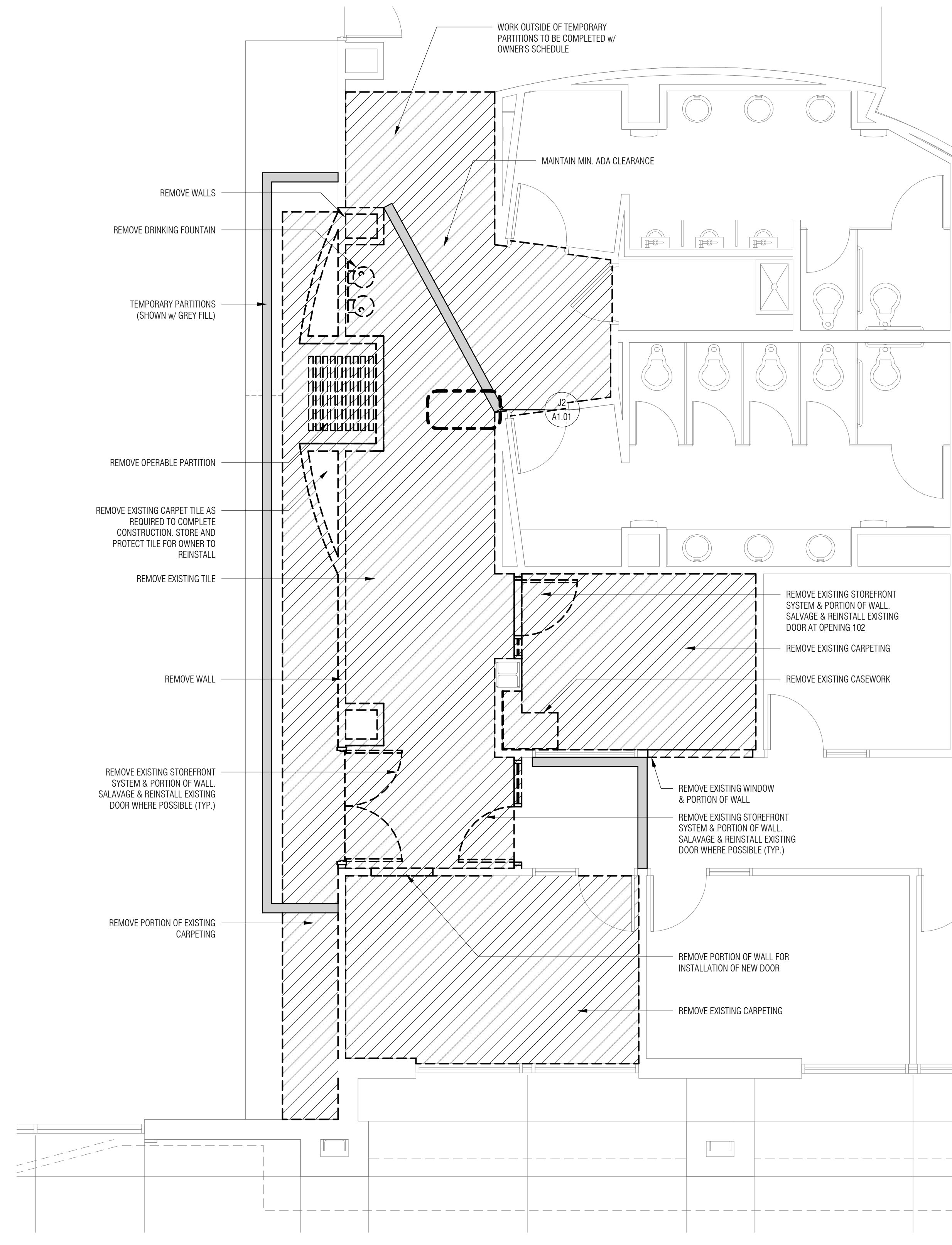

1 DEMOLITION PLAN - FIRST FLOOR
01.01 1/4" = 1'-0"

KEY PLAN:

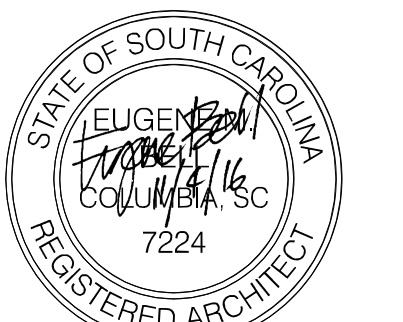
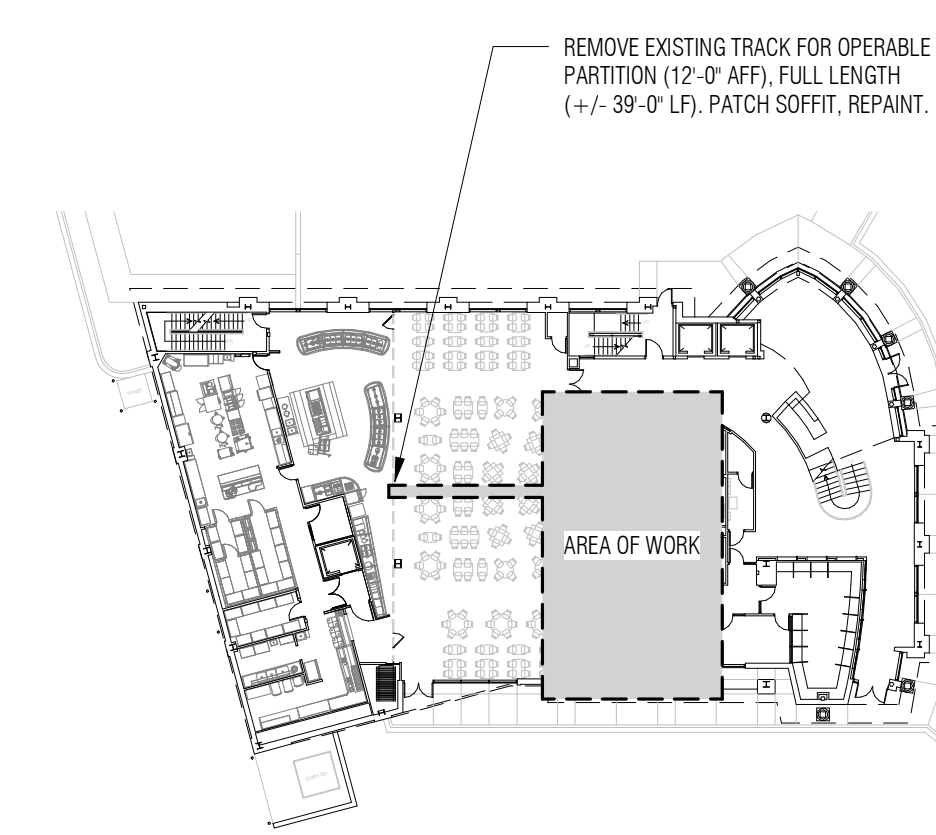

| # | DATE | REVISION |
|---|------|----------|
| | | |
| | | |
| | | |
| | | |
| | | |

These drawings are the property of Watson Tate Savory, Inc. and may not be used in whole or in part without the written consent of the architect and any infringement is subject to legal action.

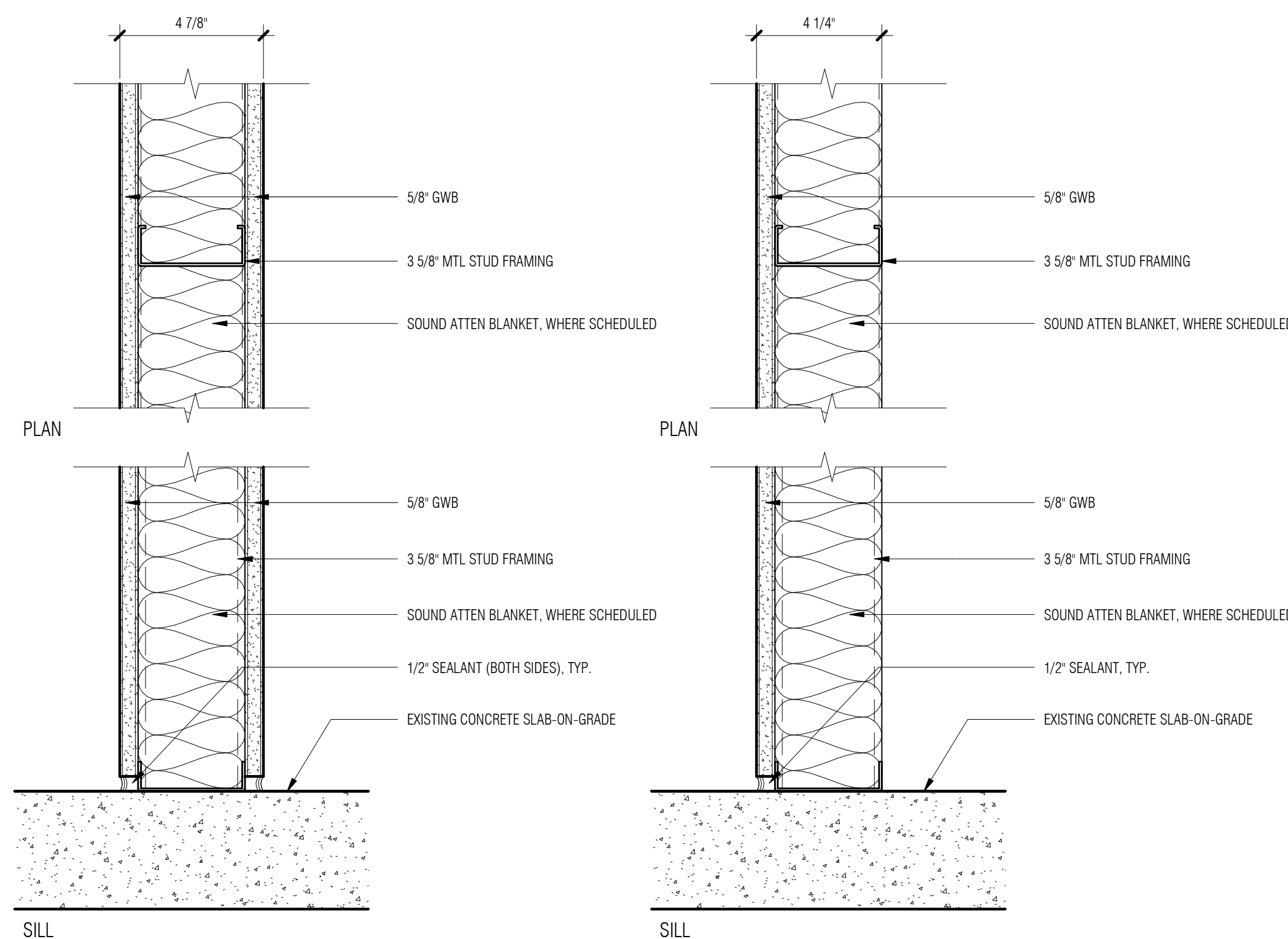

A3 PARTITION DETAIL
3' = 1'-0"

D3 PARTITION DETAIL
3' = 1'-0"

| DOOR SCHEDULE | | | | | | | | | | | | | | | |
|---------------|------------|-----------|-----------|------|--------|-------|--------|------|-------|--------|----------|---------|----------|-----------------------|--|
| MARK | DIMENSIONS | | | | RATING | PANEL | | | FRAME | | | DETAILS | | REMARKS | |
| | WIDTH | HEIGHT | THICKNESS | TYPE | | MATL | FINISH | TYPE | MATL | FINISH | HEAD | JAMB | HDWR SET | | |
| 102 | 3'-0" | 7'-0" | 1 3/4" | --- | P01 | WD | ST | F01 | HM | PT | H1 | J1 | 1 | | |
| 103 | 3'-0" | 3'-5 1/4" | 1 3/4" | --- | P01 | WD | ST | --- | HM | PT | --- | J2 | 2 | CUSTOM WD BYPASS DOOR | |
| 105A | 3'-0" | 7'-0" | 1 3/4" | --- | P01 | WD | ST | F01 | HM | PT | H1 | J1 | 3 | | |
| 106 | 3'-0" | 7'-0" | 1 3/4" | --- | P01 | WD | ST | F02 | HM | PT | H1 (SIM) | J1 | EXISTING | | |
| 108B | 3'-0" | 7'-0" | 1 3/4" | --- | P01 | WD | ST | F01 | HM | PT | H1 | J1 | 4 | | |

| FINISH SCHEDULE | | | | | | | | | | | | | | | | |
|-----------------|-------------------|----------|----------|----------|------------|----------|-----------|----------|------------|----------|-----------|----------|---------|----------|----------|----|
| NO. | ROOM | NAME | FINISHES | | NORTH WALL | | EAST WALL | | SOUTH WALL | | WEST WALL | | CEILING | | REMARKS | |
| | | | FLOOR | BASE | MATL | FINISH | MATL | FINISH | MATL | FINISH | MATL | FINISH | MATL | FINISH | | |
| 103 | NUTRITION STATION | CFT | CWT | GWB | PT | GWB | PT | EXISTING | EXISTING | EXISTING | EXISTING | GWB | PT | ACT/GWB | --- | PT |
| 105 | OFFICE | CPT2 | RB | EXISTING | EXISTING | EXISTING | EXISTING | EXISTING | EXISTING | EXISTING | EXISTING | GWB | PT | EXISTING | EXISTING | |
| 105A | STOR. | VCT | RB | EXISTING | EXISTING | GWB | PT | EXISTING | EXISTING | EXISTING | EXISTING | EXISTING | ACT | --- | --- | |
| 106 | OFFICE | CPT2 | RB | EXISTING | EXISTING | EXISTING | EXISTING | EXISTING | EXISTING | EXISTING | EXISTING | GWB | PT | EXISTING | EXISTING | |
| 113 | DINING RM | CPT1 | RB | EXISTING | EXISTING | EXISTING | EXISTING | EXISTING | EXISTING | EXISTING | EXISTING | EXISTING | ACT/GWB | --- | --- | PT |
| H102 | CORRIDOR | EXISTING | RB | GWB | PT | --- | --- | EXISTING | EXISTING | EXISTING | EXISTING | GWB | PT | EXISTING | EXISTING | |

FINISH SCHEDULE NOTES: CPT 1 AND CPT 2 ARE TO BE PROVIDED AND INSTALLED BY OWNER, BASE BY CONTRACTOR

DOOR TYPE ELEVATIONS:

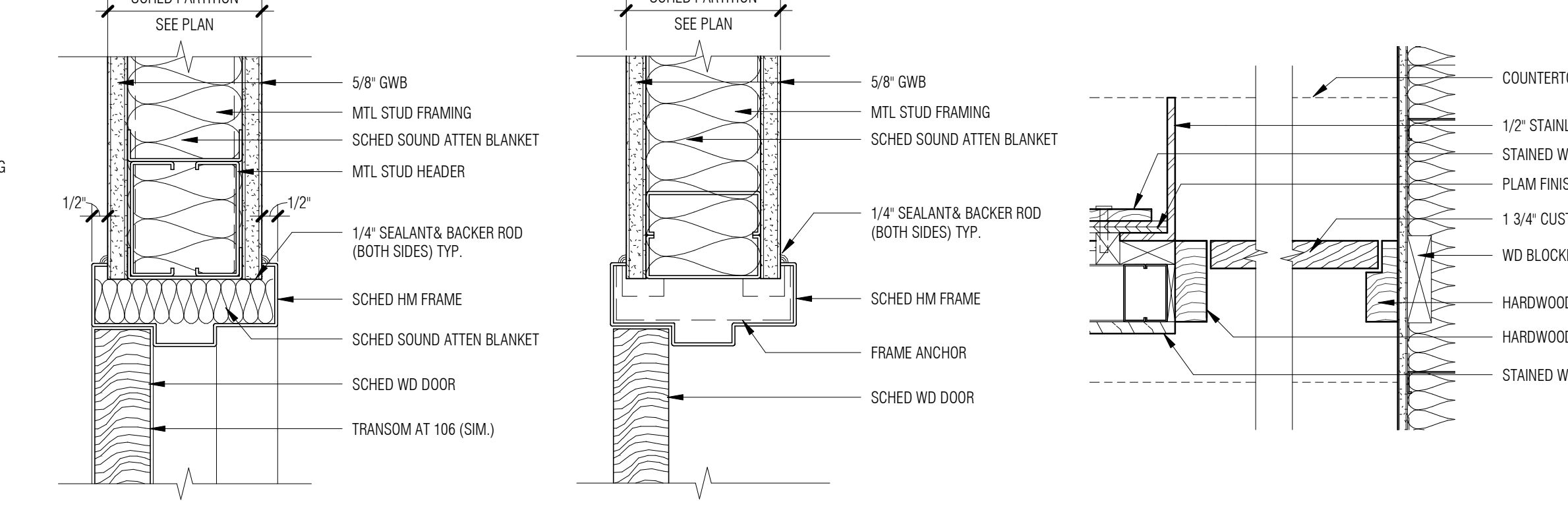
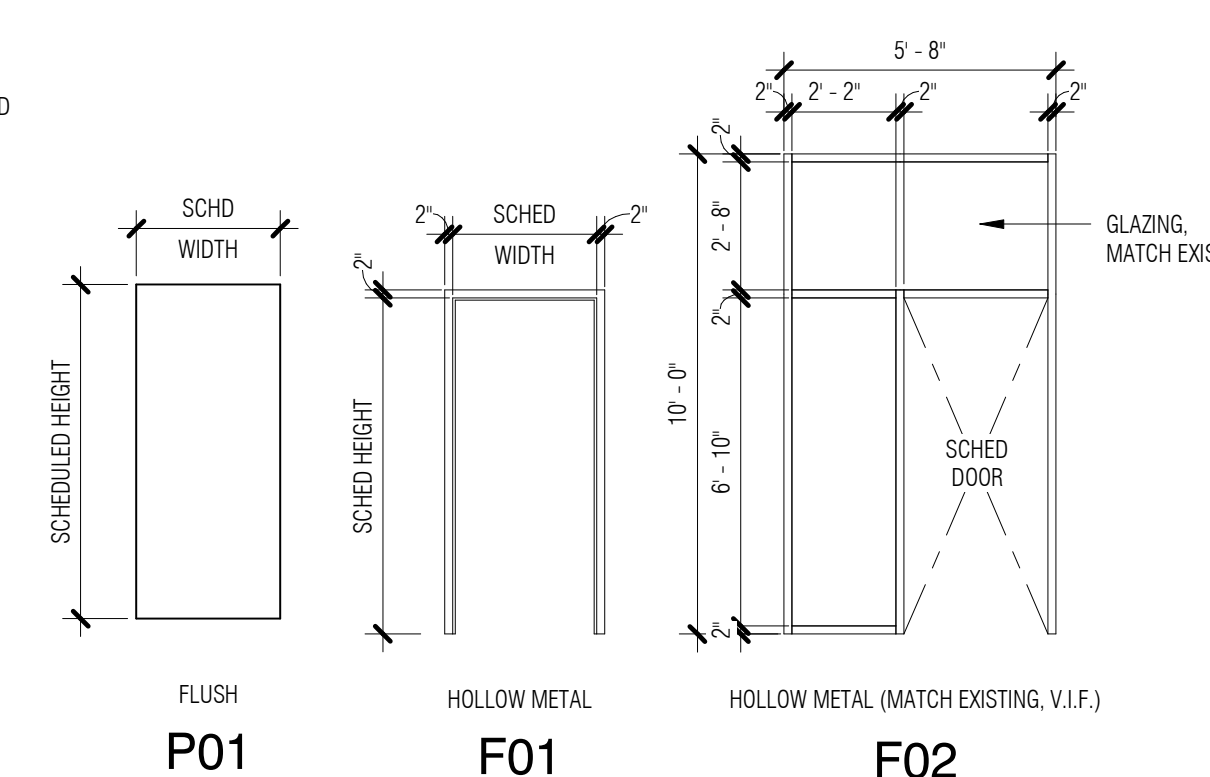

H1 HEAD DETAIL
3' = 1'-0"

J1 JAMB DETAIL
3' = 1'-0"

J2 JAMB DETAIL
1 1/2" = 1'-0"

GENERAL PARTITION NOTES:

- WHERE FIRE TESTS ARE INDICATED IN PARTITION DESCRIPTION, CONFIGURE AND INSTALL PARTITION PER TESTING AGENCY CRITERIA OR OTHER TESTS APPROVED BY LOCAL CODE OFFICIALS. TESTING AGENCY CRITERIA MAY INCLUDE ADDITIONAL COMPONENTS NOT SPECIFICALLY INDICATED ON THIS SCHEDULE OR REFERENCED DETAILS.
- DO NOT SCALE DRAWINGS. WRITTEN DIMENSIONS SHALL ESTABLISH LOCATION OF ALL PARTITIONS. LARGER SCALE DRAWINGS HAVE PRIORITY OVER SMALLER SCALE DRAWINGS. CONTRACTOR SHALL NOTIFY THE ARCHITECT OF ANY DISCREPANCIES IN THE DRAWINGS BEFORE PROCEEDING WITH CONSTRUCTION.
- GYP BD IS 5/8 INCH TYPE X FIRE RATED GYP BD, TYPICAL.
- GYP BD PARTITION CONTROL JOINTS ARE REQUIRED AT APPROXIMATELY 30'-0" O.C. FOR STRAIGHT AND CONTINUOUS WALLS. AT OPENING LOCATIONS, OR AS NOTED OTHERWISE ON DRAWINGS, WHERE NOT SPECIFICALLY INDICATED ON THE DRAWINGS, SUBMIT CONTRACTOR'S PROPOSED CONTROL JOINT LOCATIONS TO ARCHITECT FOR APPROVAL.
- DO NOT PLACE MECHANICAL AND/OR ELECTRICAL DEVICES BACK TO BACK IN SOUND BARRIER PARTITIONS. ALL DEVICES TO BE PLACED IN SEPARATE STUD SPACES WITH 8" O.C. MIN. SEPARATION.
- DUCT PENETRATIONS THROUGH SOUND BARRIER PARTITIONS TO RECEIVE PERIMETER SOUND SEAL BETWEEN DUCT AND WALL FRAMING ON BOTH SIDES OF GYPSUM WALLBOARD LAYER MEETING DUCT SURFACES.
- OUTER LAYER OF ALL INTERIOR GYP. BD. PARTITIONS ADJACENT OR EXPOSED TO HUMID CONDITIONS SHALL BE CONSTRUCTED WITH WATER RESISTANT GYP. BD. OR EQUAL AS THE SUBSTRATE. PREPARE SUBSTRATE TO RECEIVE SCHEDULED CERAMIC OR STONE TILE. WATER RESISTANT WALL PANELS OR HIGH PERFORMANCE PAINT FINISHES. HUMID SPACES INCLUDE BUT ARE NOT LIMITED TO TOILET ROOM WALLS, KITCHEN WALLS AND WALLS ADJACENT TO WATER FEATURES. USE GLASS/MAT TILE BACKING PANELS AT ALL WALLS IN DIRECT CONTACT WITH WATER, FOR EXAMPLE, SHOWERS, STEAM ROOMS, ETC. U.I.O
- FINISH ALL EXPOSED GYP BD CONSTRUCTION. ALL GYP BD CONSTRUCTION SHALL BE TAPED AND FLOATED. ALL EXPOSED CONSTRUCTION WILL BE SANDED SMOOTH TO REMOVE ALL INDICATION OF THE JOINT WITH A VISUAL INSPECTION AND PREPARED TO RECEIVE THE APPROPRIATE SCHEDULED WALL FINISH. FINISH SHALL BE IN ACCORDANCE WITH THE ROOM FINISH SCHEDULE AND/OR FINISH LEVELS NOTED IN THE GYPSUM BOARD SPECIFICATION.
- PARTITIONS ARE DIMENSIONED TO FACE OF GYP BD, FACE OF MASONRY AND TO FACE OF EXISTING CONSTRUCTION. ANY INTERIOR PARTITIONS DIMENSIONED TO FACE OF METAL STUD ARE NOTED - FOS (FACE OF STUD).
- PERIMETER DIMENSIONS ARE TO FACE OF WALL BELOW SILL U.I.O.
- PROVIDE 0.312" METAL BLOCKING AS SHOWN OR AS REQUIRED FOR ATTACHMENT OF WALL MOUNTED HARDWARE, TOILET ACCESSORIES, CASEWORK, MILLWORK, FINISH CARPENTRY, ETC. AS MAY BE REQUIRED FOR THE SECURE ATTACHMENT OF ADJOINING WORK.
- PROVIDE A 1/4" WIDE SOFT JOINT AT ALL INTERSECTIONS OF INTERIOR PARTITIONS WITH EXTERIOR WALLS. SEE TYPICAL DETAIL.

INSULATION NOTES:

- SOUND BARRIER PARTITIONS ARE NOTED AS SUFFIX 'S' AT SOUND BARRIER PARTITIONS. PROVIDE SOUND ATTENUATION BLANKET AS INDICATED IN THE TABLE BELOW. FILL VOIDS BETWEEN OVERHEAD TRACK AND STRUCTURE WITH SOUND ATTENUATION BLANKET AND SEAL PERIMETER. REFER TO SPECIFICATIONS FOR ADDITIONAL INFORMATION AND REQUIREMENTS.
- PARTITION TO EXTEND TO UNDERSIDE OF STRUCTURE ABOVE (FIRE RATED, NON-RATED, AND SOUND BARRIER PARTITION ASSEMBLIES)
- PARTITION METAL STUDS TO EXTEND TO STRUCTURE ABOVE. GYPSUM WALLBOARD ON ONE SIDE OF METAL STUD TO EXTEND TO STRUCTURE ABOVE. OPPOSITE SIDE OF METAL STUD GYPSUM WALLBOARD TERMINATES 6" ABOVE HIGHEST ADJACENT CEILING

HEIGHT CONDITIONS:

- PARTITION TO EXTEND TO UNDERSIDE OF STRUCTURE ABOVE (FIRE RATED, NON-RATED, AND SOUND BARRIER PARTITION ASSEMBLIES)
- PARTITION METAL STUDS TO EXTEND TO STRUCTURE ABOVE. GYPSUM WALLBOARD ON ONE SIDE OF METAL STUD TO EXTEND TO STRUCTURE ABOVE. OPPOSITE SIDE OF METAL STUD GYPSUM WALLBOARD TERMINATES 6" ABOVE HIGHEST ADJACENT CEILING

PARTITION TYPE LEGEND:

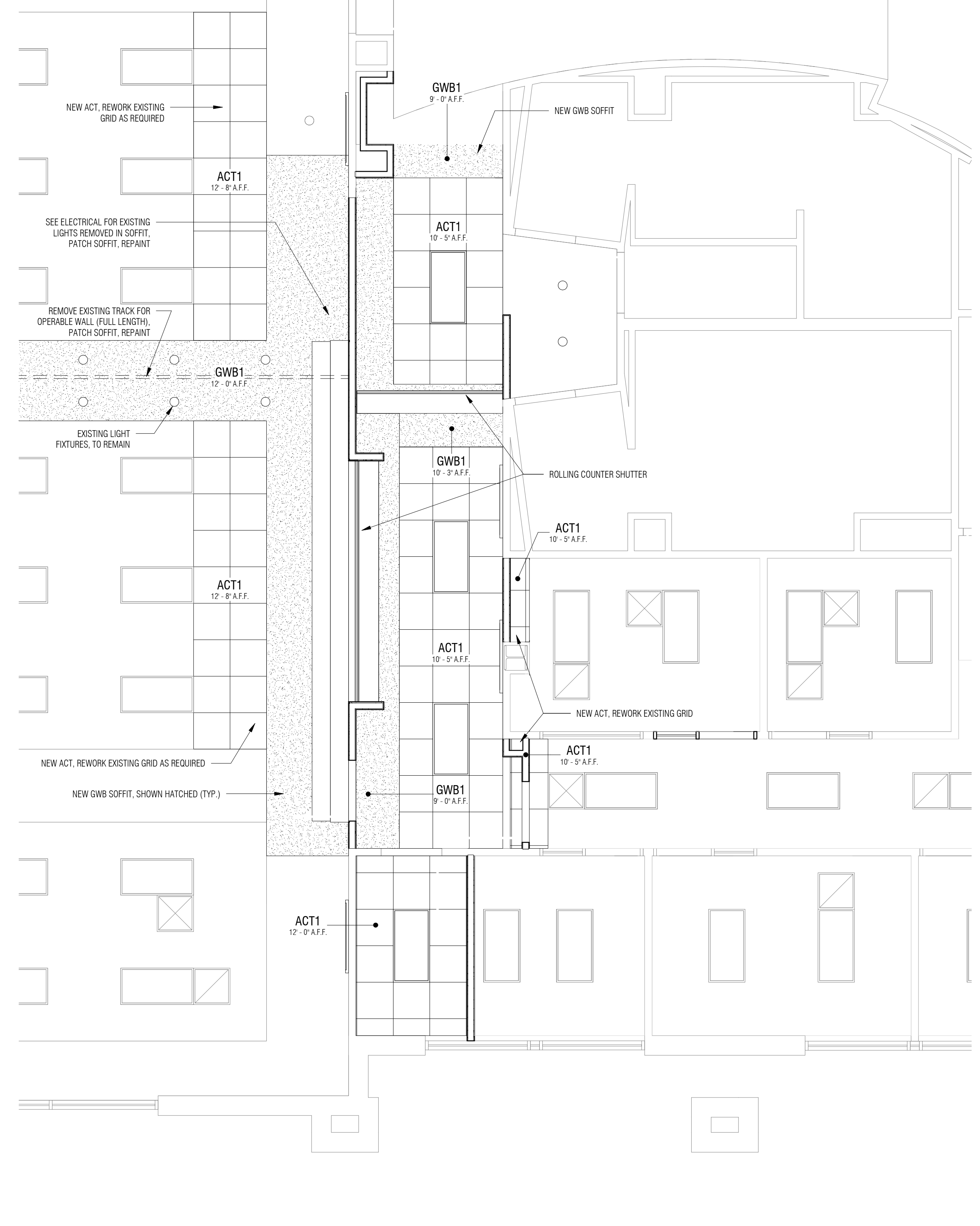

1 REFLECTED CEILING PLAN - FIRST FLOOR
1/4" = 1'-0"

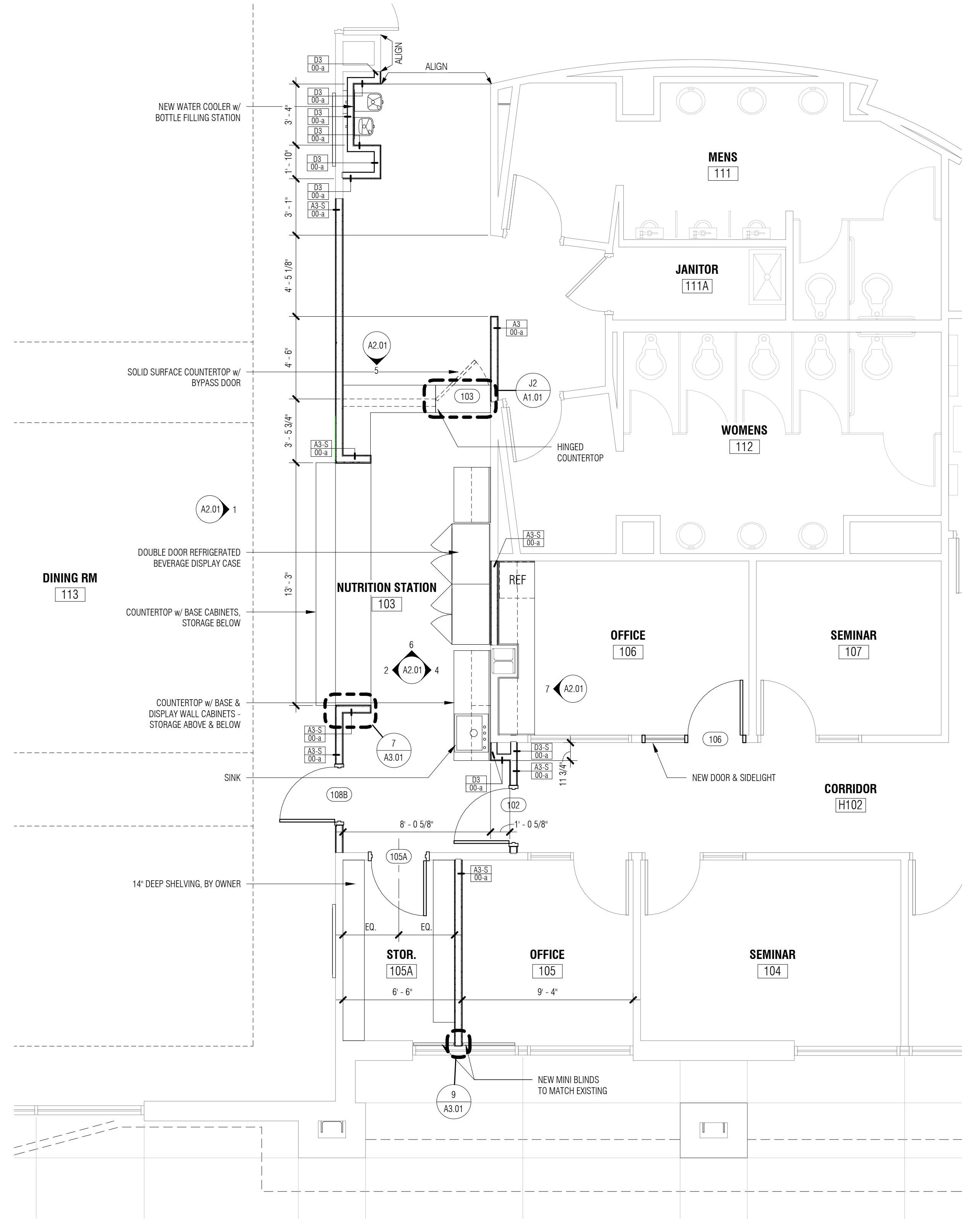

2 FIRST FLOOR PLAN
1/4" = 1'-0"

KEY PLAN:

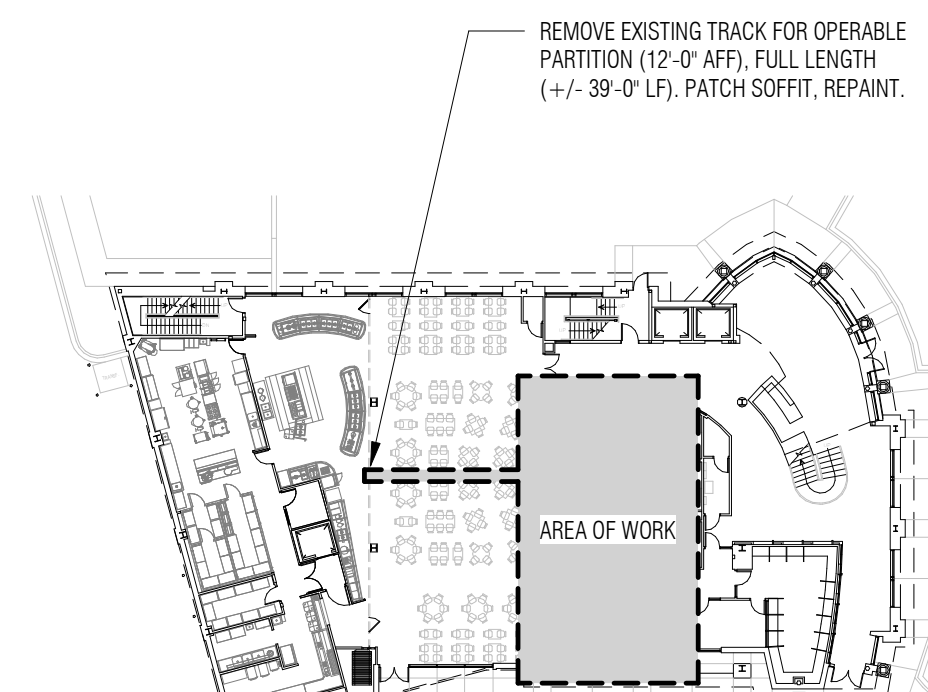

ARCHITECTURE
INTERIORS
PLANNING

WTS
WATSON TATE SAVORY



DODIE ANDERSON ACADEMIC ENRICHMENT CENTER
NUTRITION STATION
STATE PROJECT NUMBER: 427-2302



| PHASE: | CONSTRUCTION DOCUMENTS | |
|--------|------------------------|----------|
| # | DATE | REVISION |
| | | |
| | | |
| | | |

FLOOR PLAN &
REFLECTED
CEILING PLAN

11/16/2016 10:23:00 AM C:\Users\jgh\Documents\1006-ISC-Dodie Anderson Documents\1006-ISC-Dodie Anderson_ACT_gph01.rvt

These drawings are the property of Watson Tate Savory, Inc. and may not be used in whole or in part without written consent of the architect and any infringement is subject to legal action.

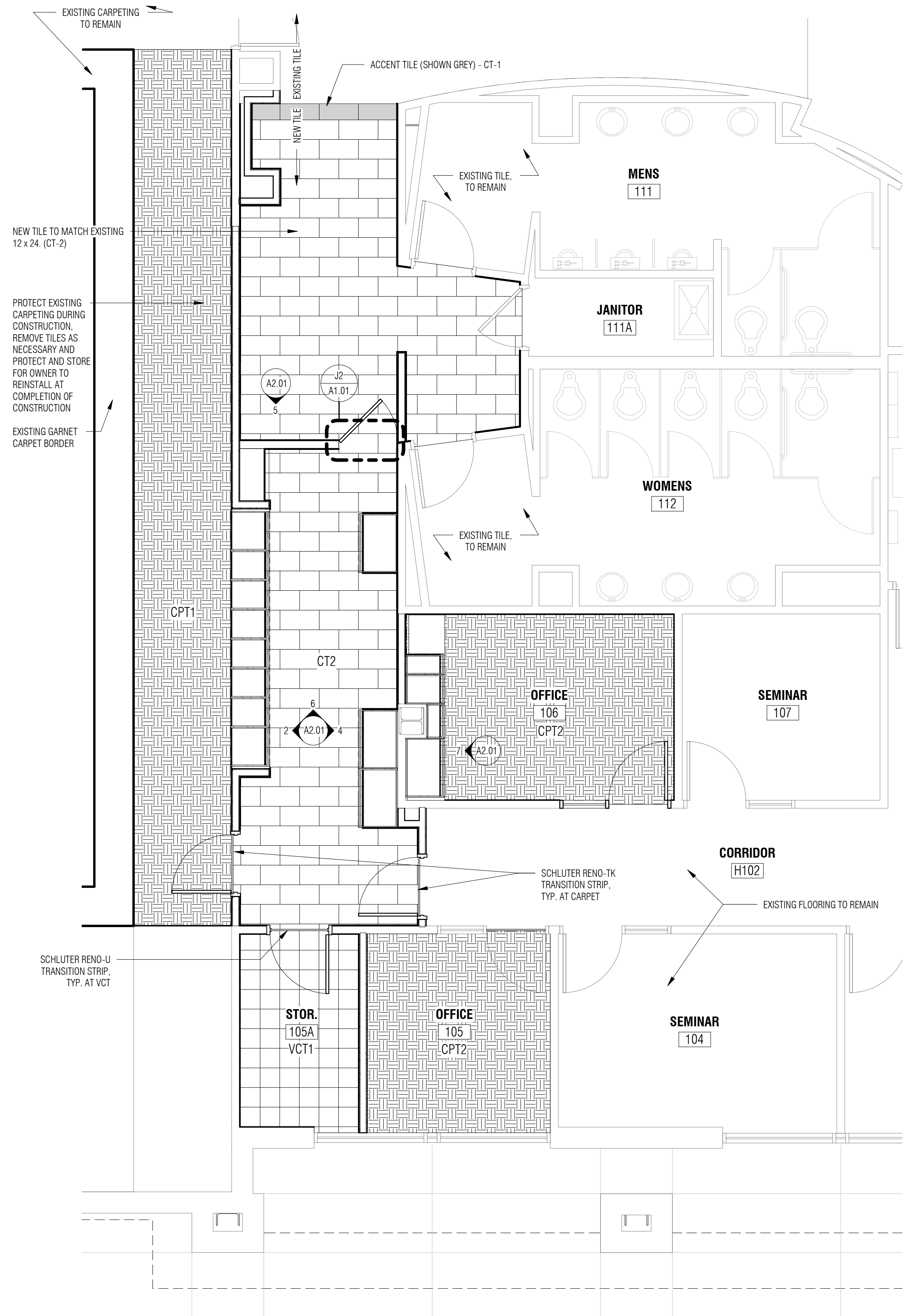

3 FINISH PLAN - FIRST FLOOR
A2.01 1/4" = 1'-0"

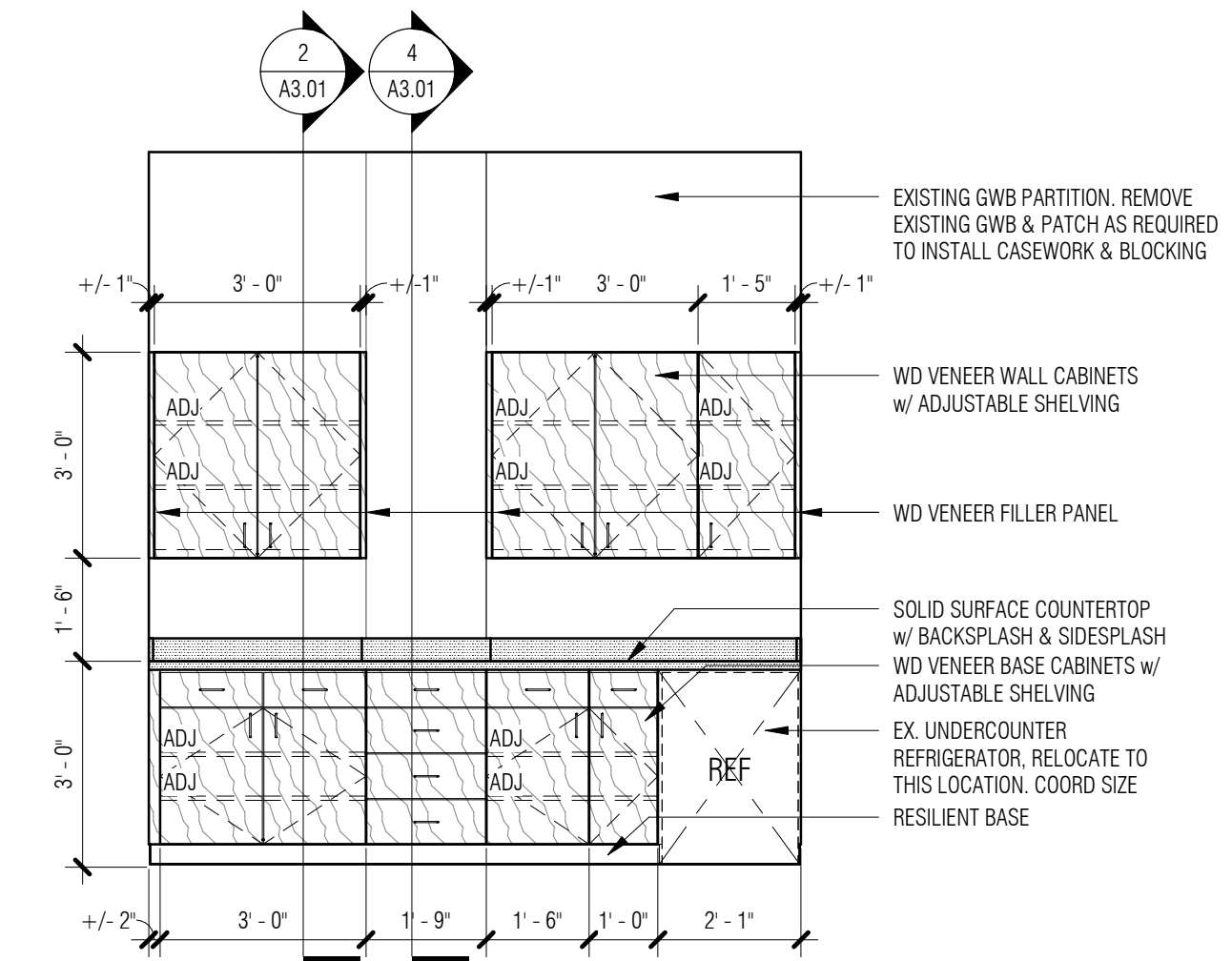

7 WEST ELEVATION - OFFICE 106
A2.01 3/8" = 1'-0"

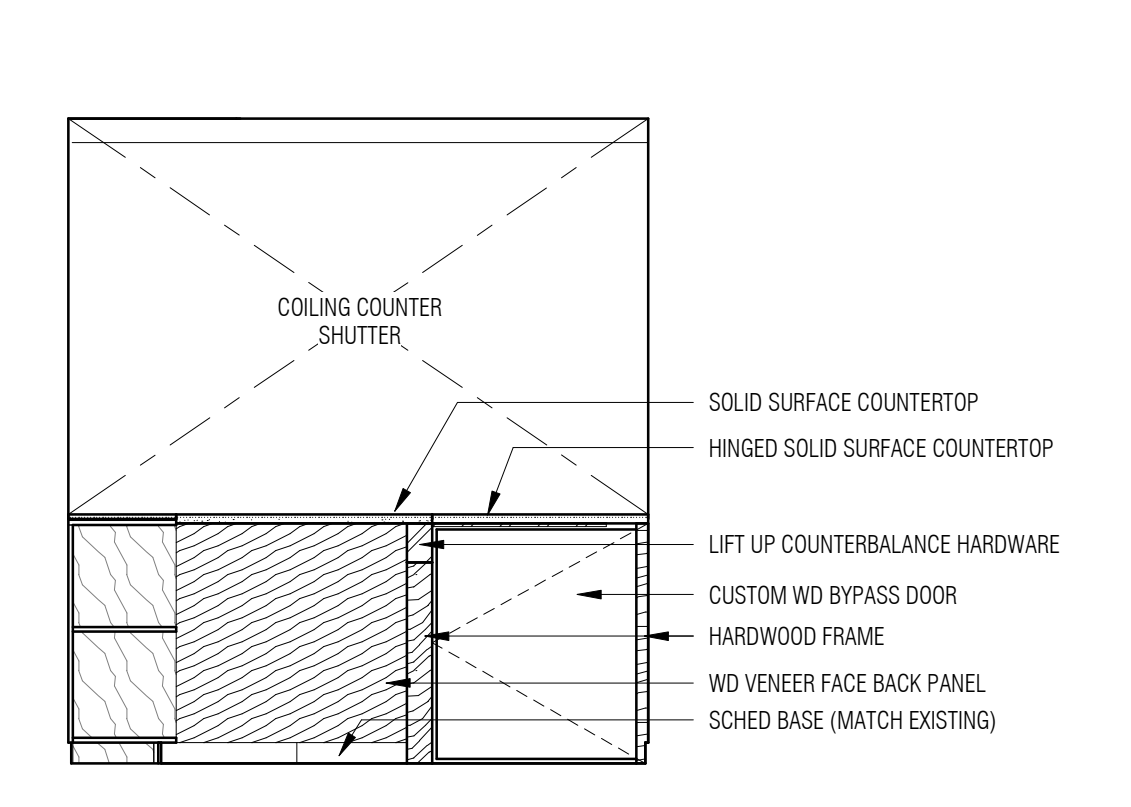

8 NORTH ELEVATION - NUTRITION STATION 103
A2.01 3/8" = 1'-0"

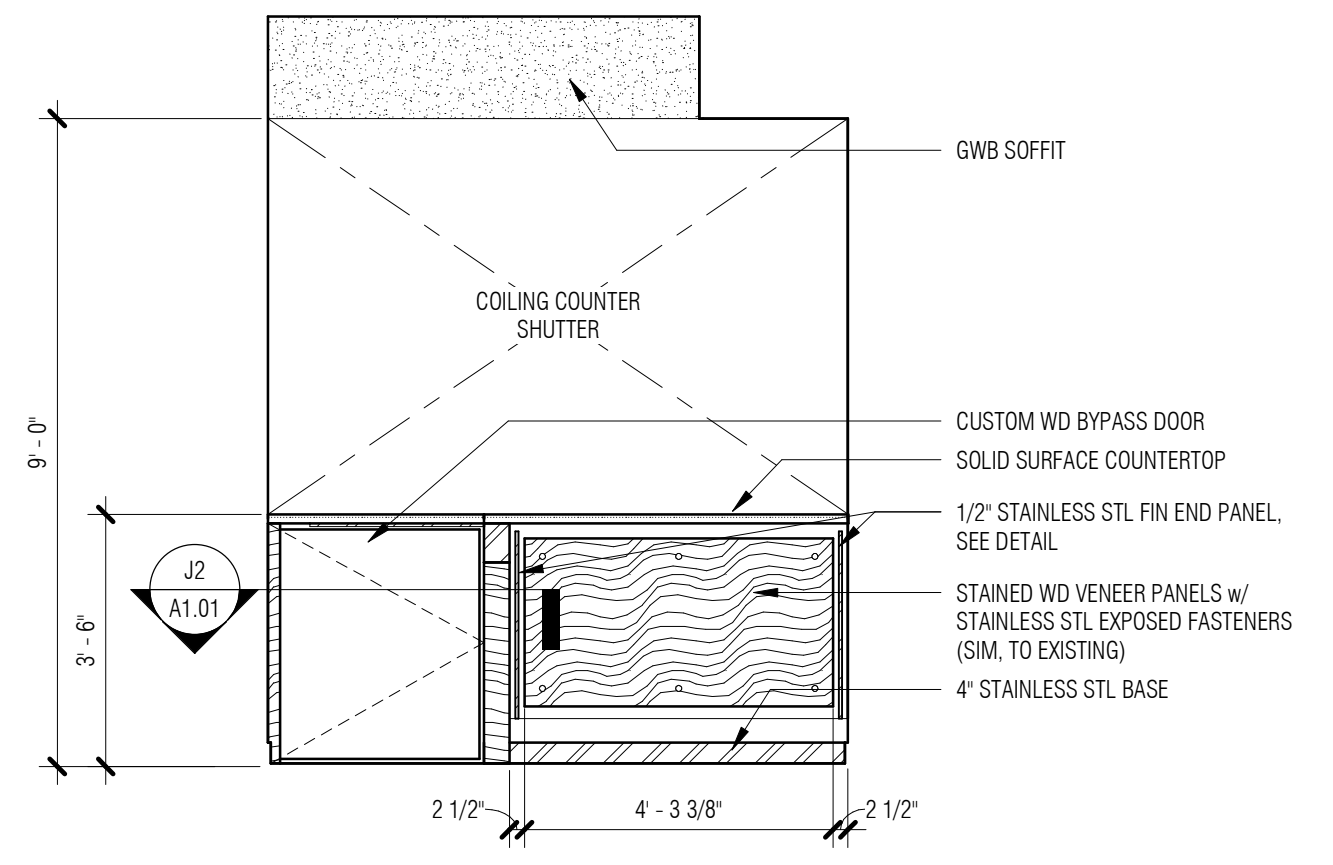

5 SOUTH ELEVATION
A2.01 3/8" = 1'-0"

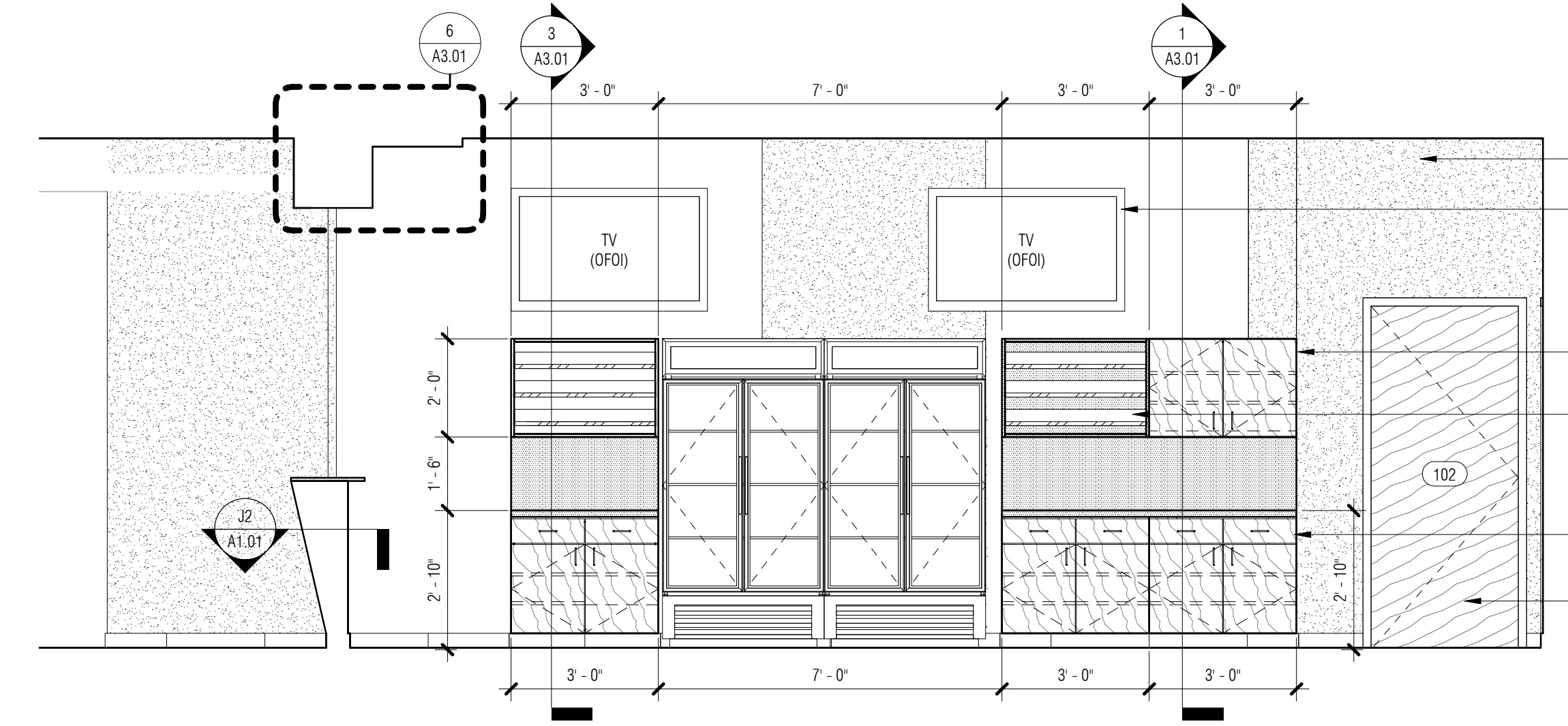

4 EAST ELEVATION - NUTRITION STATION 103
A2.01 3/8" = 1'-0"

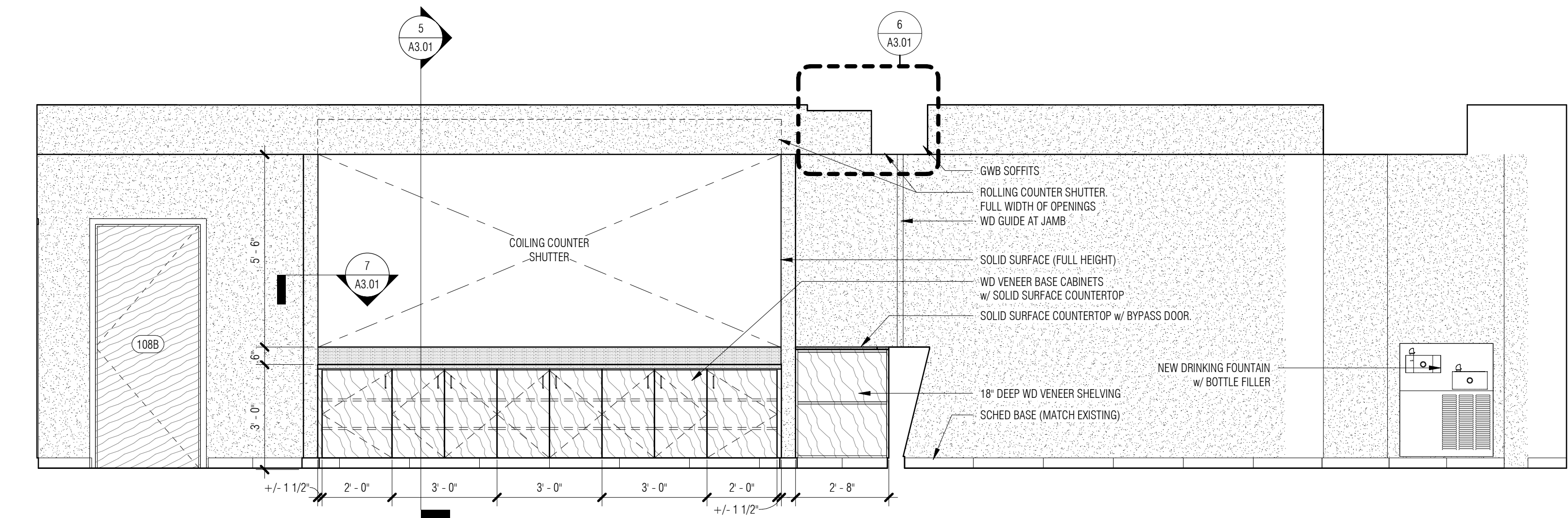

2 WEST ELEVATION - NUTRITION STATION 103
A2.01 3/8" = 1'-0"

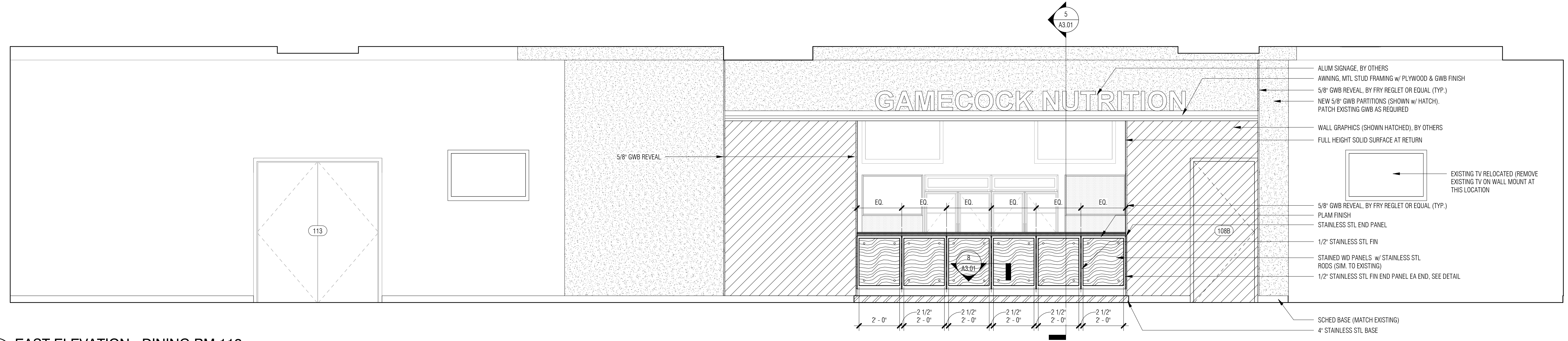

1 EAST ELEVATION - DINING RM 113
A2.01 3/8" = 1'-0"



| PHASE: | | CONSTRUCTION DOCUMENTS |
|--------|------|------------------------|
| # | DATE | REVISION |
| | | |
| | | |
| | | |
| | | |

11/16/2016 10:23:02 AM C:\users\jeh\Documents\1006-ISC-Dodie-Anderson\Drawings_A17_g001.rvt

These drawings are the property of Watson Tate Savory, Inc. and may not be used in whole or in part without written consent of the architect and any infringement is subject to legal action.

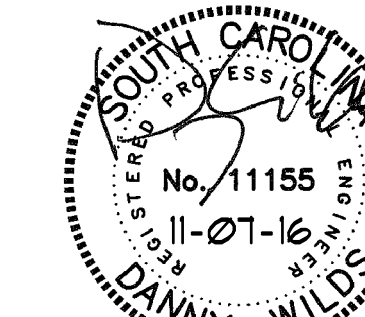

| | |
|--------|---------------|
| PHASE: | |
| # | DATE REVISION |
| | |
| | |

| AIR DEVICE SCHEDULE | | | | | |
|---------------------|--------------------------------|-------------------|----------|-------------|-------------------|
| MARK | SERVICE | NECK SIZE | MAX CFM | RUNOUT SIZE | REMARKS |
| ① | SUPPLY | 6"ø | 100 | 6"ø | W/ BUTTERFLY DFR. |
| ② | SUPPLY | 10"ø | 375 | 10"ø | W/ BUTTERFLY DFR. |
| (E) | EXISTING, BALANCE TO CFM NOTED | | | | |
| GRILLE/DIFFUSER | TYPE (NOTE 2) | PRICE # MODEL NO. | MATERIAL | | |
| SQUARE SUPPLY | PLAQUE W/ ROUND NECK | ASPD | ALUMINUM | | |

* OR EQUAL BY METALAIR, CARNES, TITUS, NAILOR, KREUGER OR APPROVED EQUAL.

NOTES: 1. GRILLE AND DIFFUSER LOCATIONS SHOWN ON FLOOR PLANS ARE APPROXIMATE, EXACT LOCATIONS SHALL BE LOCATED ON ARCHITECT'S REFLECTED CEILING PLAN.
2. GRILLES AND DIFFUSERS SHALL MATCH CEILING TYPE, DETERMINE IN FIELD.
3. GRILLE AND DIFFUSER COLORS SHALL BE SELECTED BY ARCHITECT.

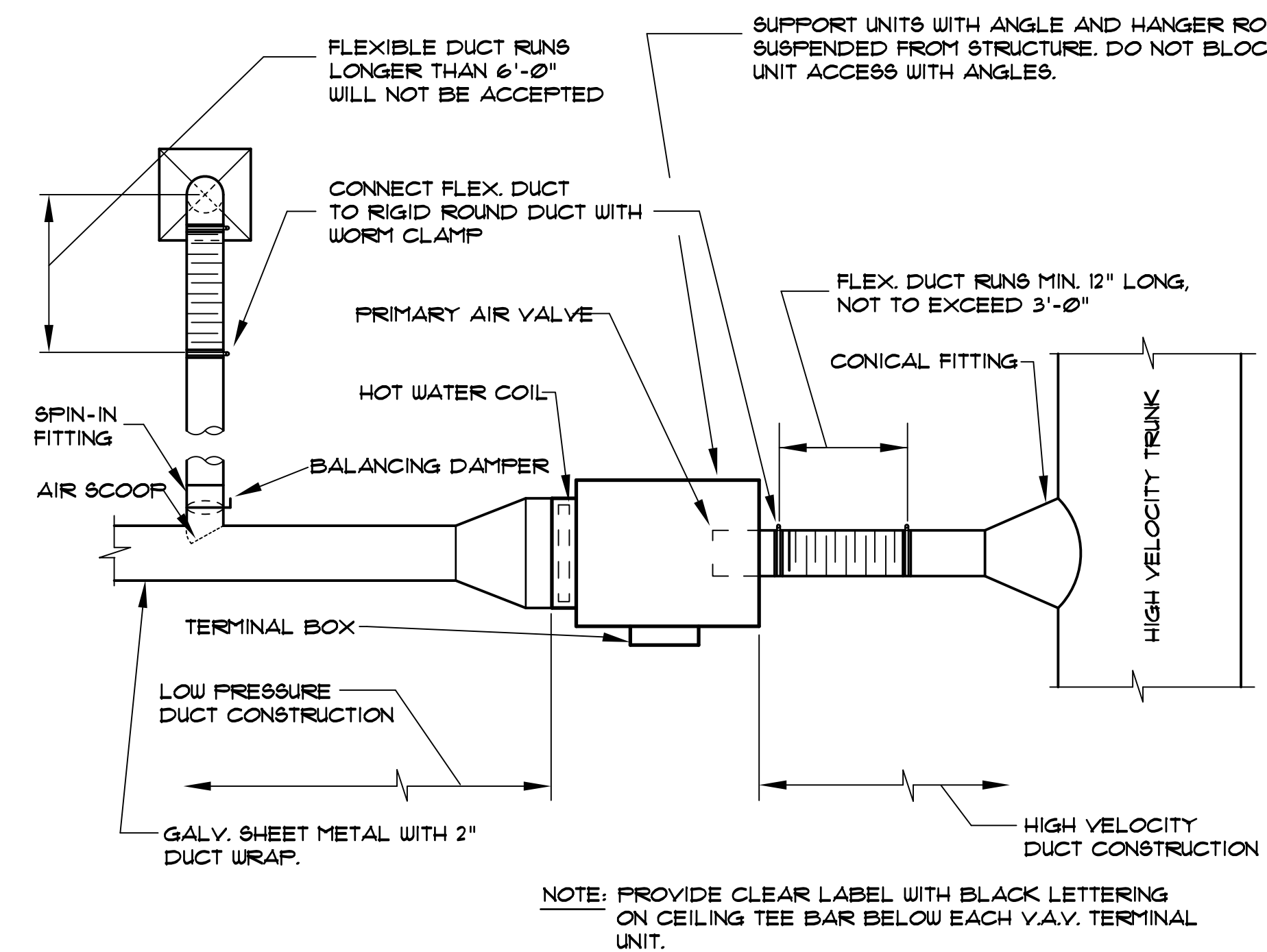

V.A.V. TERMINAL UNIT DETAIL
NOT TO SCALE

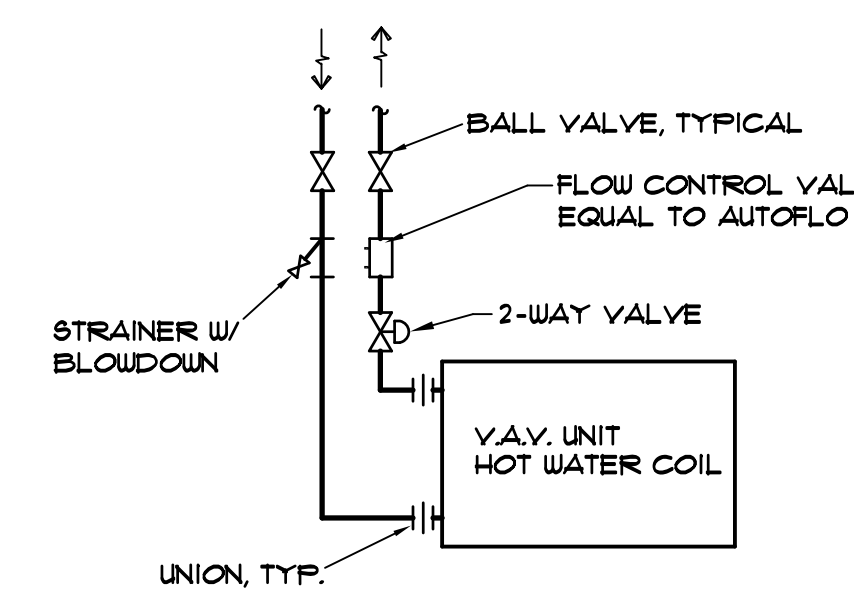

VAV HOT WATER COIL PIPING DIAGRAM
NOT TO SCALE

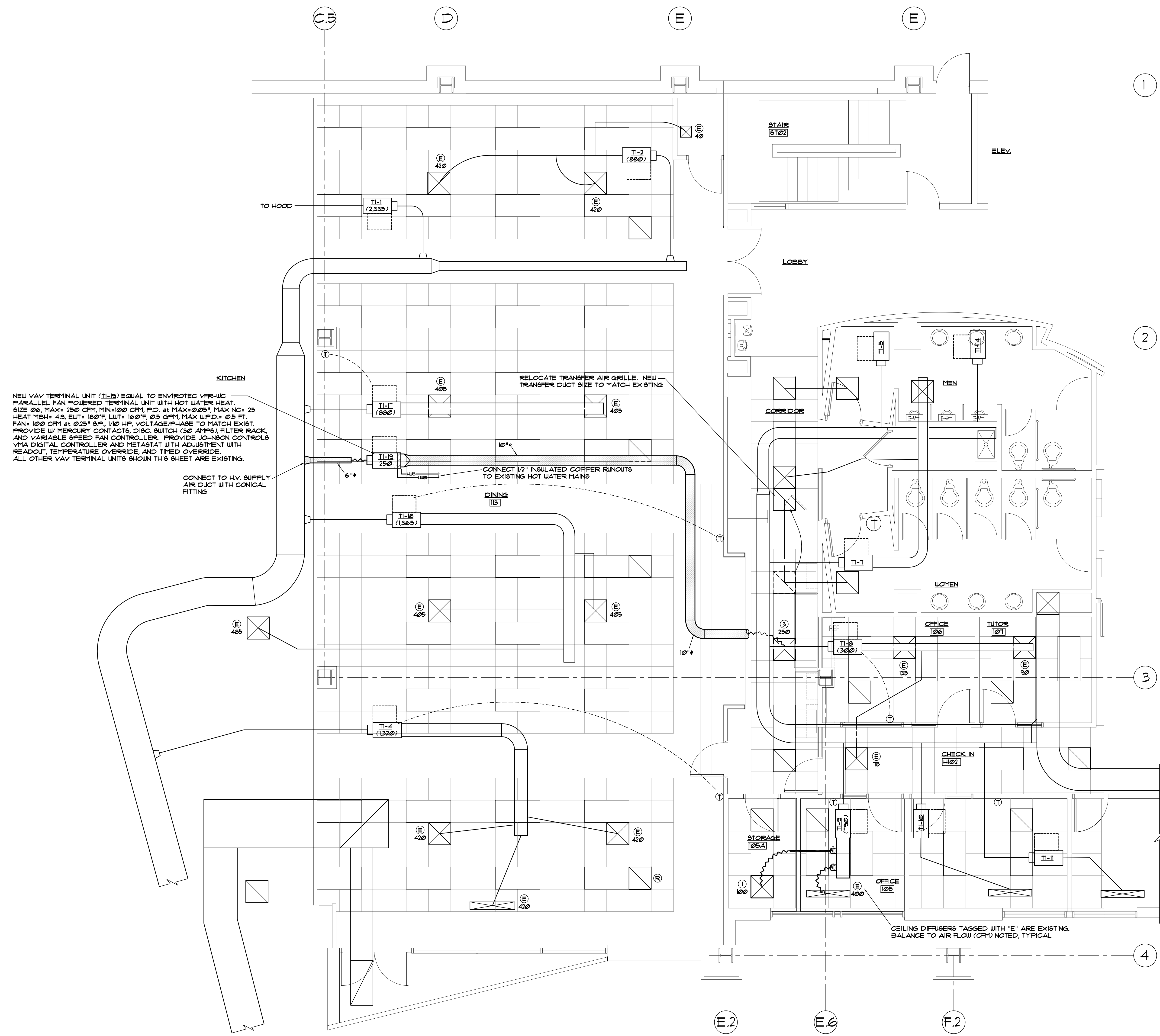

PARTIAL HVAC FLOOR PLAN
SCALE: 1/4" = 1'-0"

These drawings are the property of Watson Tate Savory, Inc. and may not be used in whole or in part without written consent of the architect and any infringement is subject to legal action.

MECHANICAL SPECIFICATIONS

1.0 GENERAL

- 1.1 All material and work shall comply with the National Fire Codes of the NFPA, National and local codes and the 2012 International Building Code and Mechanical Codes.
- 1.2 Drawings for work under Division 23 are diagrammatic and generally, indicate reasonable arrangements. Work under Division 23 includes all work necessary to make HVAC systems complete and fully operational.
- 1.3 SITE VISIT: It is highly recommended that all bidders visit the site of work and become familiar with existing conditions before submitting a bid. Submission of a bid will be considered as evidence that the Contractor has visited the site of work. No extra payments will be allowed the Contractor because of extra work made necessary by his/her failure to do so.
- 1.4 DEMOLITION ITEMS: The owner reserves the right to keep any items called for to be removed in the construction documents. Items not kept by the Owner shall be carried away from the site of work. Coordinate with Owner on each item to be removed.
- 1.5 SUBSTITUTIONS: For substitution requests made during the bidding of the project. All requests for substitutions shall be submitted in writing so as to be received by the Engineer at least ten (10) calendar days prior to final pricing and must be granted permission to quote before award of contract.

1.6 MATERIAL AND EQUIPMENT

SUBMITTALS: Submit for review detailed drawings of all equipment and all material listed in this section. All submittal data shall be bound in a hardback binder. Partial submittals will not be reviewed by the Engineer. Furnish six (6) copies of equipment submittals. Review rendered on equipment submittals shall not be considered as a guarantee of measurements of building conditions. WHERE DRAWINGS ARE REVIEWED, SAID REVIEW DOES NOT MEAN THAT DRAWINGS HAVE BEEN CHECKED IN DETAIL; SAID REVIEW DOES NOT IN ANY WAY RELIEVE THE CONTRACTOR FROM HIS RESPONSIBILITY OR NECESSITY OF FURNISHING MATERIAL OR PERFORMING WORK AS REQUIRED BY THE CONTRACT DOCUMENTS. Submit for the following materials and equipment for review by the Engineer:

1. Test and Balance Firm
 2. Duct and Pipe Insulation
 3. Air Distribution and Dampers
 4. VAV Terminal Units
 5. Automatic Temperature Controls
- 1.7 WORKMANSHIP: Work that is not of good quality will require removal and reinstallation.
 - 1.8 COORDINATION: No work shall be performed on this project before thoroughly coordinating all space requirements for pipes, control panels, and control components with all trades concerned and existing conditions. Temperature and equipment control wiring is included under Division 23.
 - 1.9 The responsibility for obtaining, cutting, and patching for work under Division 23 of the specifications is included Division 23.
 - 1.10 DAMAGES DURING CONSTRUCTION: Contractor shall be responsible for any costs of repairing any damages caused by this contractor, to the building, building contents, and site during construction and warranty period.
 - 1.11 WARRANTY: Warrant all control components, piping and any other materials specified under Division 23. Warrant all equipment, ductwork, piping and any other materials specified under Division 23 for a period of one (1) year from the date of project acceptance unless otherwise indicated. Upon failure of any part(s) of the system during the warranty period, the affected part(s) shall be repaired or replaced promptly by and at the expense of the Contractor.

- 1.12 IDENTIFICATION: Identify each piece control component. Items shall be identified by name and numerical sequence. Nameplates shall be 1/16" thick plates with 1/2" high white letters on black background. Nameplates shall be attached securely. Nameplates shall be attached securely with screws, not glued.
- 1.13 ASBESTOS

- A. At any time the contractor encounters asbestos containing materials, he shall immediately stop work and suspend any further work until asbestos containing materials are removed by others. Contractor shall, upon discovery of asbestos containing materials, notify Owner or Owner's representative, who shall be responsible for the removal of the asbestos containing materials, all in accordance with NESHAP (National Emission Standard for Hazardous Air Pollutants). Any form of asbestos removal or demolition shall be by owner. Engineer is not an "Owner or Operator" as defined under NESHAP.
- B. Contractor is responsible for, and shall be aware of all state and federal laws pertaining to asbestos as well as NESHAP requirements.

- 1.14 SEISMIC REQUIREMENTS: All materials shall comply with the 2012 International Building Code for seismic and wind requirements.

1.15 MECHANICAL: HVAC, ADJUSTING, TESTING AND BALANCING

- A. All work shall be performed by an independent Test and Balance Agency. Testing, adjusting and balancing work shall be the firm's sole source of income. All work shall be under the direct supervision of a project manager who is qualified for testing and balancing the hydronic and air performance of heating, air conditioning, and ventilating systems.
- B. Testing and balancing of the HVAC system is defined as the optimization of the installed system. The equipment schedule is used for equipment selection only. Industry standards of +/-10% are considered to be benchmarks and will not be used as an absolute requirement for final acceptance of the project. Approval of the final report will be the sole responsibility of the design engineer.
- C. Provide Testing and Balancing of the new VAV boxes, Zone Dampers, Grilles and ductless split system.

- 1.16 ACCESS DOORS: Provide heavy duty 16 ga. steel access door with primed finish, concealed hinge, and flush mounted keyed locking device. Install as directed to permit access. Provide doors as manufactured by Karp, Elmendor, Mifab, or Bilco.

2.0 MECHANICAL: HVAC, INSULATION

- 2.1 All insulation material shall have a fire hazard classification not to exceed flame spread of 25 and smoke developed rating of 50, as listed by Underwriters Laboratories and acceptable under NFPA standards. This is to apply to the complete system and to the composite insulation with jacket or facings, vapor barrier, joint sealing tapes, mastic and fittings.
- 2.2 All insulation work shall be performed by a franchised insulation company firm. All insulation shall be installed in a neat and clean manner by qualified workers in the regular employ of the insulation company.
- 2.3 DUCT INSULATION
 - A. Insulation for sheet metal ducts located inside the building shall be 2" thick Manville Microlite "commercial grade" duct wrap or equal. Insulation shall be 1 lb. density (R=7.5 min) with FSK vapor barrier.
 - B. Mastic shall be rubber cement, non-flammable equal to Epolux Cadoprene 725.
 - C. All sheet metal supply and return air ducts shall be insulated. Adhere insulation on ducts to metal with 4" strips of i insulation bonding adhesive at 8" centers. Secure insulation on ducts over 24" wide with weld pins and clip washers spaced not more than 15" o.c., to bottom of duct. Staple insulation at all seams with outward clinch staples and vapor sealed with a 3" piece of Glasfab coated completely with a flame retardant mastic. This application also applies at connections to pre-insulated flexible ductwork. Duct tape will not be allowed.

2.4 PIPE INSULATION

- A. New hot water pipes shall be insulated with 1" thick Owens-Corning one piece heavy density fiberglass pipe insulation with ASJ/SSL-II jacket.
- B. Pipe insulation not employing the double adhesive, self-seal lap shall have the lap stapled 3" on center with outward clinching staples. Two coats of low VOC vapor sealing mastic shall be applied over the staples.

3.0 MECHANICAL: HVAC, DUCTWORK

- 3.1 All ductwork shall meet job conditions and after coordinating with all trades and existing conditions. Follow duct dimensions indicated on drawings as closely as possible. Provide offsets, vary shape or alter run if required to meet structural or other interferences. Where shape of duct is varied, alter dimensions to provide equal static pressure drop per unit length.
- 3.2 Obtain copies of applicable "Sheet Metal and Air Conditioning Contractors National Association, Inc." (SMACNA) Manuals, latest edition, and keep one copy of each on job
- 3.3 Ductwork shall be air tight, smooth on inside and neatly finished on outside. Details of support, construction and materials not specified herein to be in accordance with recommendations of SMACNA.
- 3.4 No ductwork shall be fabricated or installed until all space requirements have been thoroughly coordinated with all other trades.

3.5 DUCTWORK:

- A. All supply duct down stream of terminal units, return, and outside air ducts shall be low pressure sheet metal. Seal all joints and seams with high pressure sealant.
- B. All turns greater than 45 degrees shall be made with turning vanes. Turning vanes shall be single vane type installed on runners.
- 3.6 HIGH VELOCITY SUPPLY DUCTWORK: Ductwork shall be in accordance with SMACNA "High Velocity Duct Construction Standards," latest edition unless otherwise approved. High velocity duct shall be installed in accordance with manufacturer's recommendations. Round duct to be equivalent to Uni-Rib duct with Uni-Weld fittings as manufactured by United Sheet Metal, Semco, Don Park, Inc., Eastern Sheet Metal or approved equal. Duct shall be of spiral lock seam construction with an intermediate standing rib to provide the rigidity equivalent to ASHRAE standard gauge duct. The duct and fittings shall be fabricated of 900 galvanized steel meeting ASTM A527-71, and of a thickness not less than 26 gauge. Fittings and couplings shall be 26 gauge. High velocity runout to VAV terminal units shall be conical type, spot-welded to the trunk duct and sealed with a low VOC bonding material having a neoprene base.

4.0 AIR DISTRIBUTION

- 4.1 GRILLES AND DIFFUSERS
 - A. Unless otherwise indicated, color and finish to be as selected by Owner.
 - B. Maximum noise level on any unit shall be at least 5 less than noise criteria level (NC) for which room is designed unless otherwise indicated. Room NC to be assumed to be 35 unless known. Maximum pressure drop shall not exceed 0.1" w.g. unless otherwise noted.
 - C. Grilles and diffusers shall be Price model numbers listed in schedule on drawings or equal by Krueger, Carnes, Metalaire, Nailor or accepted equal.
- 4.2 SPIN-IN TAKE-OFFS
 - A. Take offs to ceiling supply diffusers shall be a factory fabricated spin-in type takeoff with an aircoop and balancing damper.

4.3 TERMINAL UNITS

- 4.4 All variable air volume terminal units shall be Trane of capacity, etc. as specified herein or equal by Titus, Price, Metalaire, JCI, Nailor, or approved equal.
- 4.5 VAV Terminal Units:

- A. Shall be DDC controlled with factory installed JCI V.A.V. box application specific controllers as provided by Johnson Controls Inc. (JCI). The air valve actuator shall be factory supplied and installed. For each VAV terminal unit provided, factory wire and factory checkout.
- B. 24VAC, 50VA control transformer. Coordinate primary voltage of transformer with JCI to match available power requirements.
- C. 24VAC floating tri-state electrical damper actuator.
- D. Terminal strip for connection of unit mounted devices, field devices and communication cable. For each VAV terminal unit factory install, factory pipe, factory wire and factory checkout the following items that will be provided by the controls contractor as specified under division 23 and shipped to the VAV terminal unit manufacturer:

1. DDC terminal unit controller.
2. Differential pressure sensor.
- E. Coordinate installation of controls with controls contractor to insure that controls are properly installed and wired.
- F. Units shall be a cooling, pressure independent, single duct VAV box. Unit shall be completely factory assembled to include modulation of primary air quantity and controls as specified. Unit shall have single discharge suitable for flanged or slip connection to rectangular low pressure duct work.
- G. Terminal units shall be completely factory assembled, manufactured of corrosion protected welded steel, and fabricated with a minimum of 18-gauge metal on the high pressure (inlet) side of the VAV damper and 26-gauge metal on the low pressure (outlet) side and unit casing.
- H. All interior surfaces shall be acoustically and thermally insulated with a minimum of 1", 1-1/2 lb. density glass fiber with high density facing for erosion protection. The insulation shall be UL listed and approved for requirements per standard NFPA/ASTM E84/SOT. Insulation shall be installed such that no cut edges are exposed to the airstream.
- I. Low pressure discharge distribution arrangement shall be rectangular open ended discharge suitable for connection to distribution duct transitions.
- J. Each unit shall be individually tagged as indicated for job site placement. Tagging shall be applied to both the unit and any shipping cartons or containers.
- K. V.A.V. terminal units shall be provided with an access door in the side of the unit for access to unit. Ensure proper access to valve from high pressure connection to unit. Ensure proper access to control panel from low-pressure side of unit.
- L. Terminal unit shall include an integral hot water coil. The coil shall be manufactured by the terminal unit manufacturer and shall have a minimum 22 gauge galvanized sheet metal casing. Stainless steel casings, or galvanized steel casings with a baked enamel paint finish may be used as an alternative. Coil shall be constructed of pure aluminum fins with full collars to assure accurate fin spacing and maximum tube contact. Fins shall be spaced with a minimum of 10 per inch and mechanically fixed to seamless copper tubes for maximum heat transfer. Each coil shall be hydrostatically tested at a minimum of 450 psig under water, and rated for a maximum 300 psig working pressure at 200°F. Coils shall incorporate a built in, flush mounted access plate, allowing top and bottom access to coil.

5.0 AUTOMATIC TEMPERATURE CONTROLS

- 5.1 SCOPE OF WORK:
 1. The complete control system shall be provided and installed by Johnson Controls Inc. (JCI).
 2. Provide new controllers, sensors, and thermostats as outlined in the specifications below and the drawings.
- 5.2 WARRANTY: The entire control system shall be warranted free of defects and shall include required servicing and maintenance for one year after final acceptance.
- 5.3 CONTROL AND INTERLOCK WIRING:
 1. All electrical work required under this section of specifications shall comply with the 2011 National Electrical Code. Control system power supply shall be served by a separate breaker and fused in control center for secondary protection.
 2. All control wiring located below grade or outdoors shall be installed in rigid conduit. All control wiring in walls or above the ceiling (or in equipment rooms) shall be run in galvanized EMT. PLENUM CABLE WILL NOT BE ACCEPTED.
 3. Control wiring shall be color coded #16 TFF of TFFN wire with 600 volt insulation. Run all wiring between terminal points without changing color. Color code of control wiring shall be as indicated on control wiring diagram. Multi-conductor thermostat cable will not be acceptable.

5.4 SEQUENCE OF OPERATION:

VAV TERMINAL UNITS

1. Occupied cooling - The wall mounted temperature sensor will modulate the cooling VAV terminal units open from the minimum CFM setpoint to the maximum CFM setpoint in order to maintain the occupied space temperature setpoint (74°F, adjustable). The minimum and maximum CFM setpoints on VAV terminal units shall be as listed in the VAV Terminal Unit Schedule. If the space temp continues to rise above setpoint with the VAV terminal unit at the maximum CFM position, the controller shall enable the zone damper to open.
 2. Occupied heating - the controller shall open the VAV terminal unit damper to its minimum position and open the hot water control valve as required to maintain the space temperature setpoint (70°F, adjustable).
 3. Unoccupied mode - The controller shall follow the same sequence as listed above for the occupied mode with setback cooling/heating setpoints. (Cooling - 84°F, Heating - 60°F, programmable).
- 5.5 Label all new controllers with engraved bokoilite plastic plates indicating control function and correct set point. Label shall clearly relate to controller by functional name as indicated on control wiring diagram.
- 5.6 Furnish to engineer two copies of certifications signed by authorized representative that:
1. Control system has been checked-out and operates according to drawings and specifications.
 2. All controls are warranted unconditionally for one year from date of acceptance and will be serviced for this period free of charge.
 3. Maintenance personnel or responsible party has been instructed as to the operation of control system.

END OF DIVISION 23

ARCHITECTURE
INTERIORS
PLANNING

WTS
WATSON TATE SAVORY



DODIE ANDERSON ACADEMIC ENRICHMENT CENTER
NUTRITION STATION

STATE PROJECT NUMBER: H27-Z302

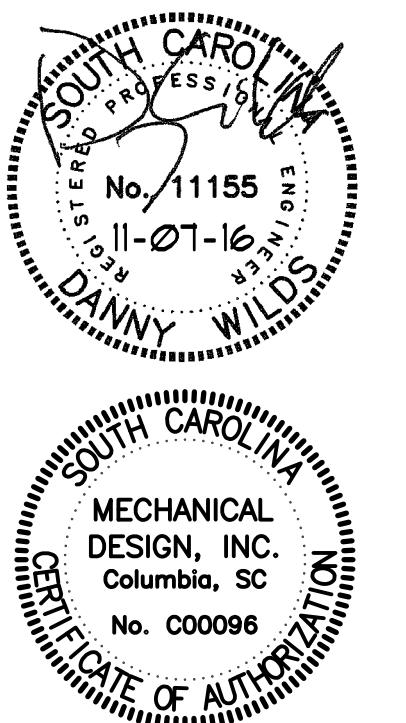

| | | |
|--------|------|----------|
| PHASE: | | |
| # | DATE | REVISION |
| | | |
| | | |

HVAC
SPECIFICATIONS

These drawings are the property of Watson Tate Savory, Inc. and may not be used in whole or in part without written consent of the architect and any infringement is subject to legal action.

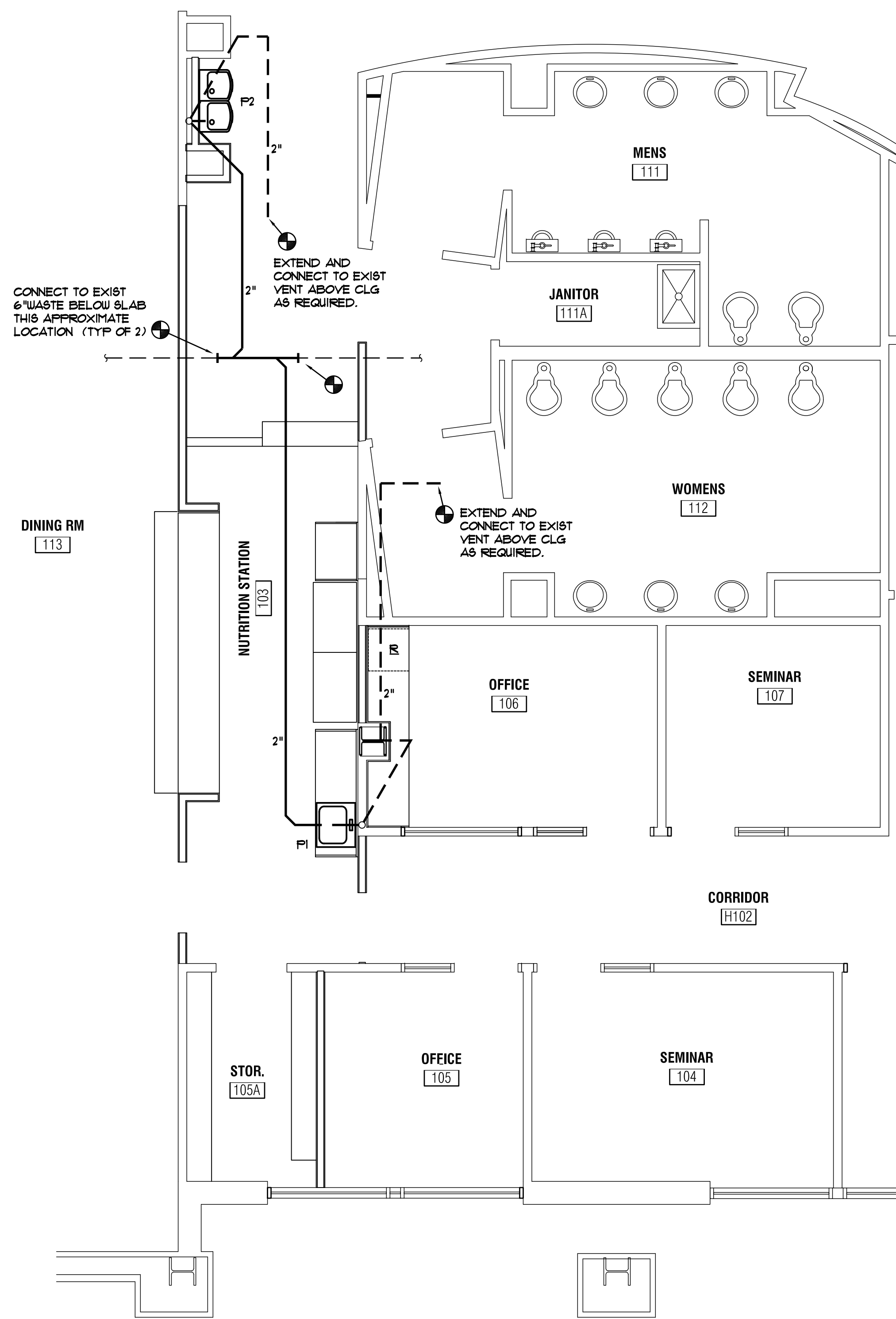

WASTE AND VENT PIPING RISER

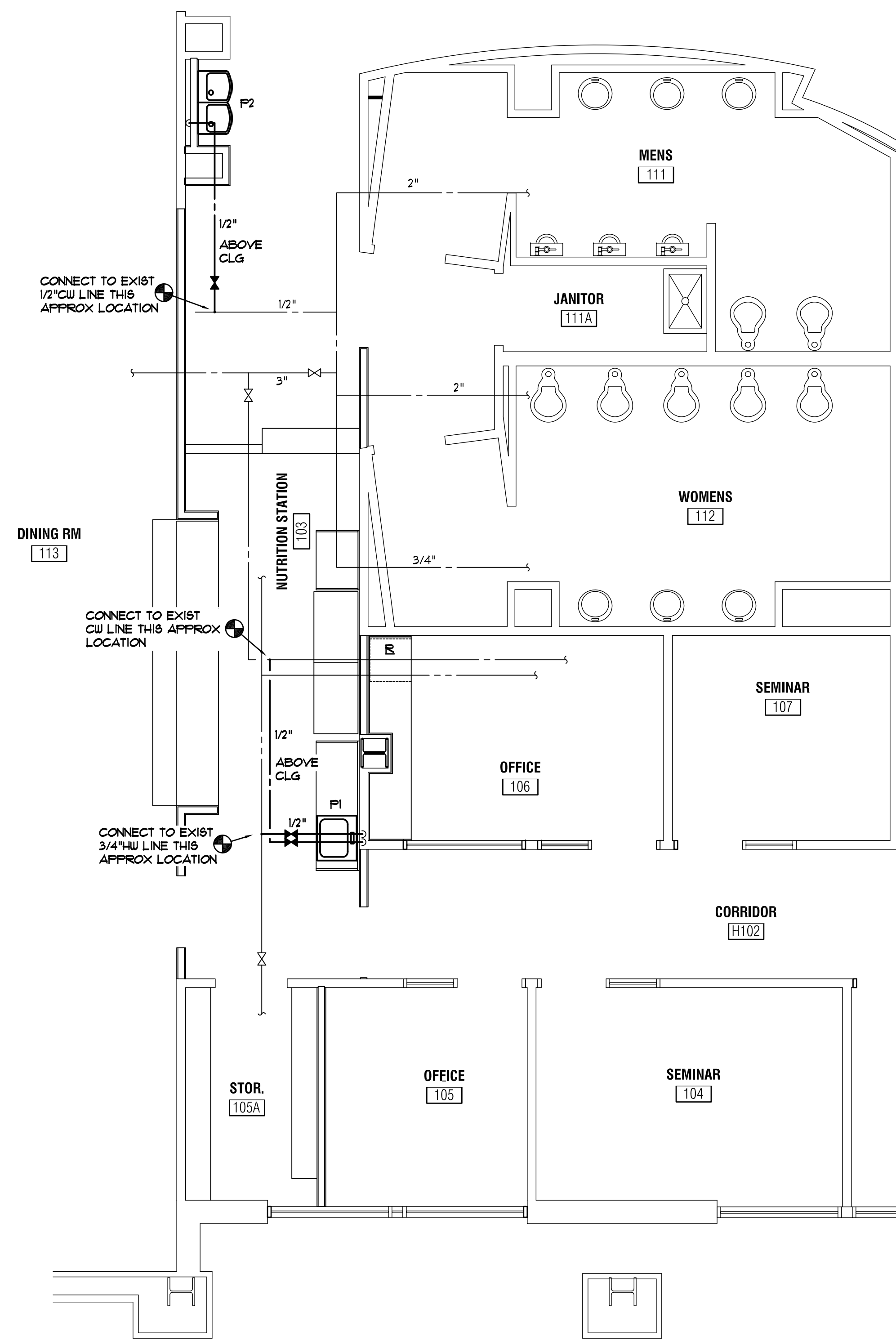

WATER PIPING RISER

PARTIAL PLUMBING FLOOR PLANS

SCALE: 1/4" = 1'-0"

| PLUMBING FIXTURE SCHEDULE | | | | | | |
|---------------------------|-----------------------------|------|------|-------|--------|-----------------|
| SYMBOL | DESCRIPTION | CW | HU | WASTE | VENT | MOUNTING HEIGHT |
| F1 | HDC'D 1-COMP SINK | 1/2" | 1/2" | 2" | 1-1/2" | SEE ARCH |
| F2H | HDC'D ELECTRIC WATER COOLER | 1/2" | --- | 2" | 1-1/2" | Ⓐ |

FIXTURE KEY:

- Ⓐ MOUNT CENTERLINE OF HDC'D BUBBLER 34-1/2" AFF TO MEET ADA GUIDELINES.
- Ⓑ ELECTRIC WATER COOLER TO BE FURNISHED WITH BOTTLE FILLING STATION (SEE SPECIFICATIONS)

PLUMBING NOTES

1. DO NOT SCALE DRAWINGS. ROUGH FROM EXIST CONDITIONS, ARCHITECTURAL DRAWINGS AND EQUIPMENT MANUFACTURER'S DRAWINGS.
2. COORDINATE PLUMBING SYSTEMS WITH ALL TRADES TO AVOID INTERFERENCE AND CONFLICTS PRIOR TO INSTALLATION OF PIPING, FIXTURES, AND EQUIPMENT.
3. ALL WORK AND MATERIALS SHALL BE IN ACCORDANCE WITH THE (IBC) BUILDING AND (IPC) PLUMBING CODES, 2018 EDITIONS OF THE (ICC) INTERNATIONAL CODE COUNCIL WITH SOUTH CAROLINA AMENDMENTS, AND ALL LOCAL CODES AND ORDINANCES.
4. WHENEVER THE WORD "PROVIDE" IS USED, IT SHALL MEAN FURNISH AND INSTALL COMPLETE AND READY FOR USE.
5. UNLESS OTHERWISE SHOWN OR NOTED, ALL PIPING SHALL BE RUN CONCEALED IN WALLS, CHASES AND/OR ABOVE CEILINGS.
6. PROVIDE AIR CHAMBERS ON HOT AND COLD WATER SUPPLY TO EACH FIXTURE. (SEE DETAIL, THIS SHT.)

PLUMBING SYMBOLS

| SYMBOL | DESCRIPTION |
|---------|--------------------------|
| --- | SANITARY WASTE PIPING |
| - - - - | SANITARY VENT PIPING |
| --- | COLD WATER PIPING |
| --- | HOT WATER PIPING (110°F) |
| ⊕ | BALL VALVE |
| ⊕ | CONNECT TO EXISTING |
| CW, HU | COLD WATER, HOT WATER |

PLUMBING DEMOLITION NOTES

- D1. CONTRACTOR SHALL FIELD COORDINATE AND VERIFY EXIST CONDITIONS PRIOR TO START OF DEMOLITION WORK. NOTIFY ENGINEER IMMEDIATELY IF QUESTIONS OR CONFLICTS ARE DISCOVERED AT START OF PROJECT.
- D2. REFER TO ARCHITECTURAL DEMOLITION PLANS FOR FIXTURES BEING REMOVED. REMOVE ALL WASTE WATER AND VENT PIPING FOR FIXTURES TO POINT OF CONCEALMENT ABOVE CLG / BELOW SLAB AS REQUIRED.
- D3. PROVIDE SAUCUTTING, CUTTING, CORE DRILLING AND REMOVAL OF EXIST FLOOR SLABS AND/OR EXIST WALLS AS REQUIRED FOR THE DEMOLITION AND INSTALLATION OF PLUMBING SYSTEMS. COORDINATE ALL DEMOLITION WITH GENERAL CONTRACTOR TO MAINTAIN MINIMAL AMOUNT OF CUTTING / PATCHING AS REQUIRED.
- D4. PATCHING OF EXIST FINISHES SHALL BE BY THE GENERAL CONTRACTOR.

1.1 SCOPE:

- A. Provide all related equipment, labor, materials, excavation and backfill, operations and accessories required for the installation of complete and quietly operating plumbing systems, in accordance with the plans and specifications.

1.2 EXCAVATION AND BACKFILLING:

- A. Provide all excavating and backfilling for work under this Division of the contract.
- B. Upon completion of tests and inspections, backfill with approved material, placed and tamped to prevent excessive settlement.

1.3 SOIL, WASTE AND DRAIN PIPE:

- A. Soil, waste and vent piping below slab shall be sch 40 PVC solid plastic pipe, ASTM D1785 and D2665 with solvent cement drainage pattern fittings. Install with joints prepared with purple primer in accordance with code.
- B. Soil, waste and vent piping above slab shall be No-Hub cast iron pipe and fittings, ASTM A-74 and WW-P-401d with standard CISPI couplings.

1.4 HOT AND COLD WATER PIPING:

- A. Hot and cold water piping above slab shall be hard drawn copper, Type L with soldered wrought copper fittings. Use lead-free hard solder (95/5) for all joints located above slab.
- B. All valves and components shall be lead-free in accordance with Federal Public Law 111-380 (The Reduction of Lead in Drinking Water Act).

1.5 VALVES:

- A. Provide lead-free ball valves for hot and cold water piping where noted. Valves shall be sized according to line sizes shown.
- B. Ball valves shall be two piece, designed with minimum working pressure of 600 psi with full port, sweat type, chrome plated ball and blow-out proof stem. The manufacturer name and working pressure to be cast on valve body.
- C. Install valves with stems upright within 15 degrees of the vertical plane.
- D. Valve handles shall be malleable iron. Die-cast aluminum handwheels will not be accepted.

- E. Valves to be the product of one of the manufacturers and model numbers shown in the following table or accepted equal:

| Ball Valves 2" and smaller (Bronze, Sweat) | Hammond | Apollo | Nibco |
|--|---------|----------|-------------|
| | UP8311A | 70LF-200 | S-585-80-LF |

1.6 PIPE INSULATION:

- A. Above ground hot and cold water piping shall be insulated with 1" thick 25/50 rated one piece fiberglass insulation with embossed vapor barrier laminated jacket. Pipe fittings shall be insulated with same material and thickness as pipe. Insulation shall conform to HH-1-558B, Form D, Type III, Class 12; NFPA 90A and MIL-1-223.
- B. Water piping in interior chase may be insulated with 1/2" thick insulation in lieu of 1" specified above.

1.7 PIPE SUPPORTS:

- A. Perforated strap hangers, chain or wire will not be permitted on the job.
- B. Support horizontal piping above ground with hangers, threaded rods and turnbuckles as mfd. by Grinnell, Fee and Mason, PHD Hangers, or approved equal.
- C. Support copper pipe with copper or copper plated hangers, spaced not over 6 feet apart for 1/2" pipe and 8 feet apart for larger pipes.

1.8 FIXTURES:

- A. Provide heavy cast stop valves for all fixtures as follows: Equal stop valves by EBC or Zurn will be accepted.
Sink (3/8"): McGuire H165-F
Water Cooler (3/8"): McGuire H165-F
- B. Provide heavy c.p. cast brass p-traps with brass nuts and c.o. plug as follows:
Sink (1-1/2" x 1-1/2"): McGuire 8912-C
EWC (1-1/4" x 1-1/4"): McGuire 8872-C
- C. Electric water cooler shall be as manufactured by Oasis or equal unit with Halsey Taylor or Elkay with stainless steel panels and chrome plated brass bubblers.
- D. Sink shall be as manufactured by Just or equal by Elkay.

- E. Faucets shall be as manufactured by Chicago or equal by Zurn or T&S Faucet. Provide vandal resistant and water saving features on all faucets. Vandal features shall include hex socket screws for all handles, key operated 1.5 GPM aerator and abrasive washers for all single faucet shank fittings.

- F. Plumbing fixtures shall be as specified below:

P1 Hdc'd 1-Comp Sink; Just 2119-ADA-AGR, 18 ga. self-rimming, 5-1/2" deep single compartment stainless steel sink, four hole punch, rear drain outlet, Chicago 200-CP-ONBA-E3-VPC mixing faucet with 8" swing gooseneck, 4" wrist blade handles, hose spray and Snap-N-Loc SS-306 basket strainer. Provide TrueBro "Basin Guard" undersink protective enclosure. Enclosure to be field measured and cut to suit cabinet opening below sink.

P2H Hdc'd Electric Water Cooler; Oasis PBAMBFSL, dual wall hung unit with hands-free Versafiller bottle filler, stainless steel panels, steel frame construction, touchpads, located on both front and sides of each unit and CP brass bubblers. Provide chair carrier to suit construction. Secure both top and bottom of unit to chair carrier.

1.9 STERILIZATION OF HOT AND COLD WATER SYSTEMS:

- A. Sterilize with a solution containing not less than (50) parts per million of available chlorine. Use sodium hypochlorite solution conforming to Federal Specifications OS-441-A, Grade D. Solution to remain in system for (24) hours, opening and closing all valves several times. After sterilization, flush with clean water until chlorine is not greater than 0.2 parts per million.
- B. Have samples collected from throughout the systems on (2) consecutive days tested by an approved independent testing laboratory and deliver certificates of approval to County Sanitarian, and Owner. All laboratory fees shall be included in the plumbing contract. Contractor shall be responsible for preventing use of water from systems for human consumption until tested and approved. Should any of the tests prove unfavorable, the entire disinfection and sampling process shall be repeated.
- C. After the (24) hour retention period of the disinfection solution, the treated water should contain no less than 25 mg/l chlorine throughout the length of pipe.
- D. Certificates indicating negative results of bacteriological tests shall be procured prior to building acceptance.

1.10 TESTS:

- A. Pressure and leak test all water piping at minimum 150 PSI for 4 hours and in accordance with local requirements.
- B. Test entire waste, sanitary drainage and venting pipe systems by plugging all necessary openings and filling systems with minimum 10'-0" water column, or to the top of highest vent stack.

1.11 GUARANTEE:

- A. Contractor shall guarantee all piping and materials installed under this Division of work from leaks and defects for a period of one (1) year from the date of project acceptance unless required otherwise. Upon failure of any part(s) of the system during the guarantee period, the affected part(s) shall be repaired or replaced promptly by and at the expense of the Contractor.
- B. If any component fails during the regular one year period, then the replacement part(s) shall be given an additional one (1) year guarantee from the time of replacement. This shall continue until the items have given one (1) year satisfactory service.

END OF SPECIFICATIONS

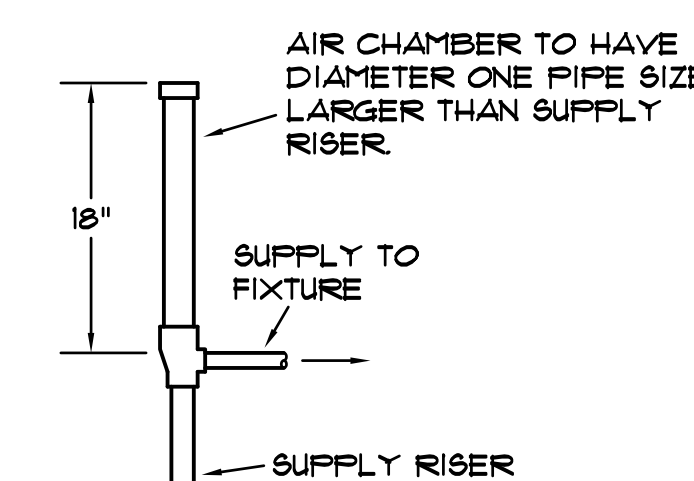

AIR CHAMBER DETAIL

NO SCALE

- SPECIAL NOTES:**
1. (IPC) PLUMBING CODE PARAGRAPH 604.9 APPLIES TO QUICK-CLOSING VALVES ONLY.
 2. THIS PROJECT DOES NOT CONTAIN QUICK-CLOSING VALVES.

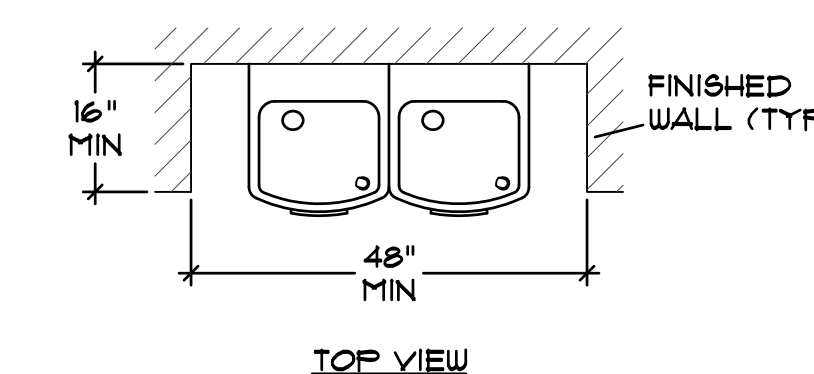

TOP VIEW

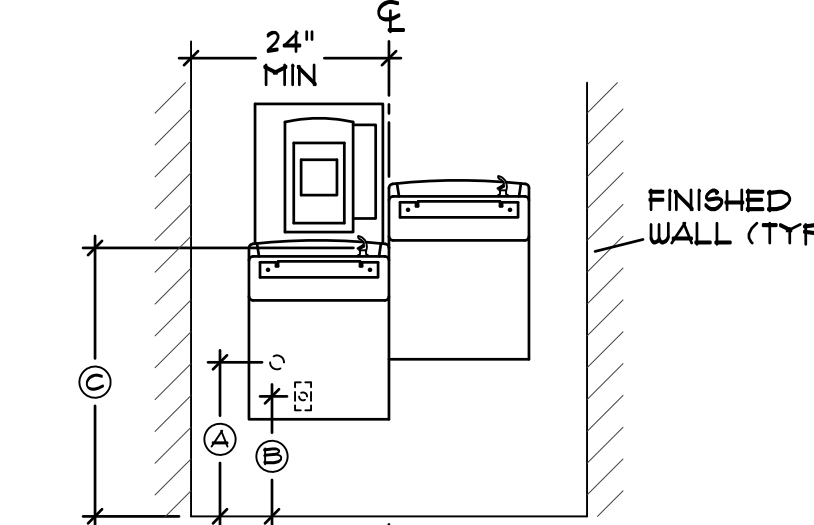

FRONT VIEW

HANDICAPPED

HDC'D DUAL EWC INSTALLATION

NO SCALE

- KEY:**
- Ⓐ WASTE OUTLET - VERIFY WITH MFR PROVIDED.
 - Ⓑ ELEC OUTLET - COORDINATE AND VERIFY EXACT LOCATION OF ELEC OUTLET BEHIND UNIT WITH DIV 16 ELEC. ELEC OUTLETS WILL NOT BE ACCEPTED EXPOSED.
 - Ⓒ MAXIMUM 34-1/2" AFF TO CENTERLINE OF BUBBLER.
 - Ⓓ REFER TO ARCH DRGS FOR ACTUAL DIMENSIONS AS APPLICABLE.

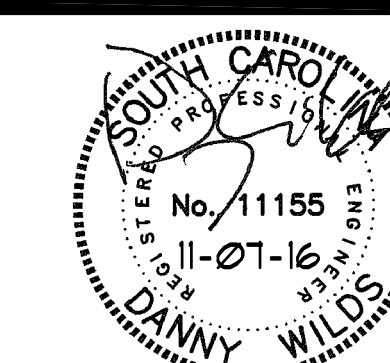

| | | |
|--------|------|----------|
| PHASE: | | |
| # | DATE | REVISION |
| | | |

PLUMBING FLOOR PLAN

These drawings are the property of Watson Tate Savory, Inc. and may not be used in whole or in part without written consent of the architect and any infringement is subject to legal action.

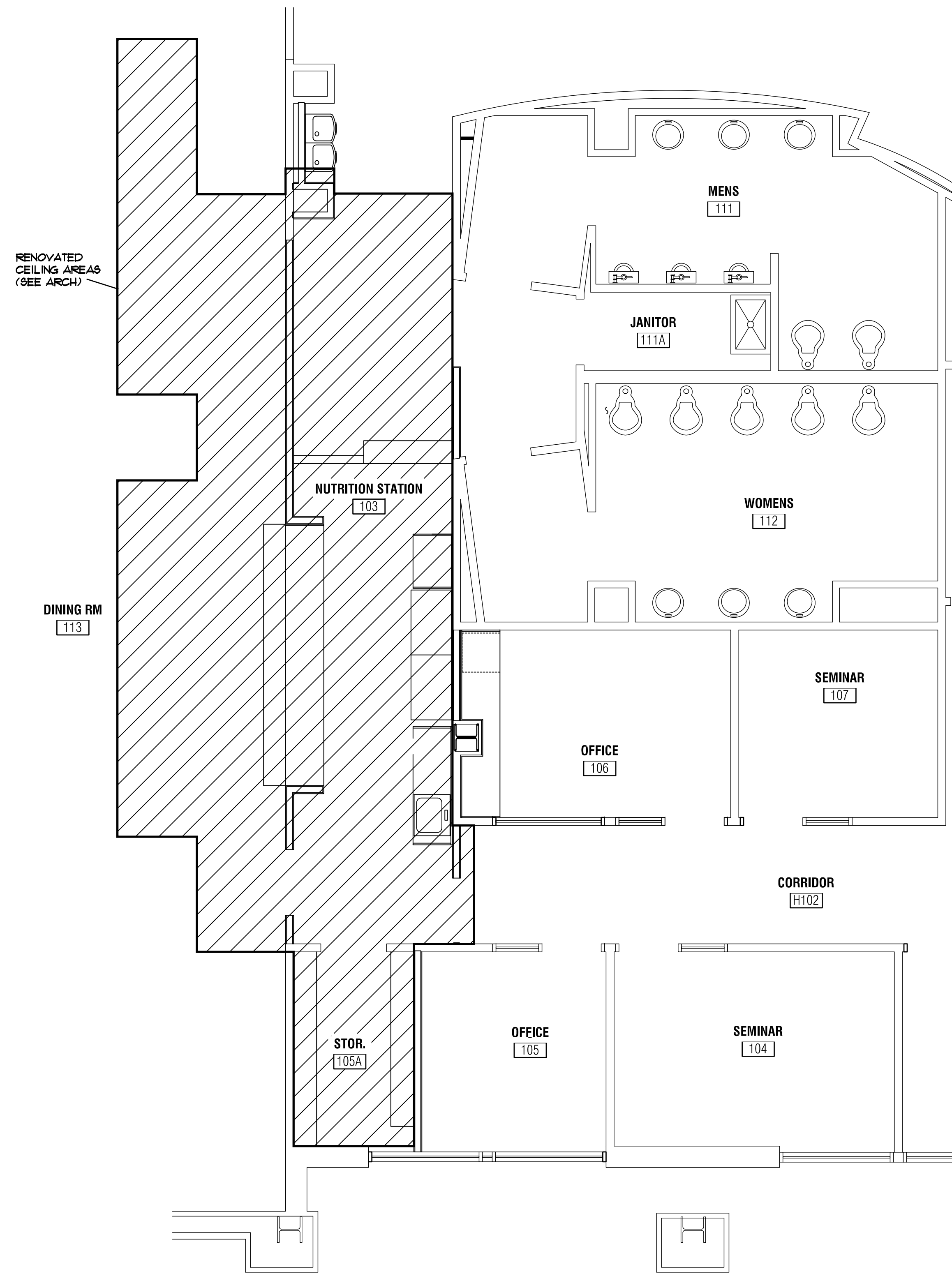

PARTIAL SPRINKLER PLAN
SCALE: 1/4" = 1'-0"

- SPRINKLER SYSTEM NOTES / SPECIFICATIONS**
- F1. DO NOT SCALE DRAWINGS. ROUGH FROM ARCHITECTURAL DRGS AND EXISTING CONDITIONS. COORDINATE CEILING FINISHES AND HEIGHTS AS APPLICABLE.
 - F2. ALL WORK AND MATERIALS SHALL BE IN ACCORDANCE WITH NFPA 13 - 2013 AND ALL APPLICABLE LOCAL CODES AND ORDINANCES.
 - F3. COORDINATE SPRINKLER SYSTEMS WITH ALL TRADES TO AVOID INTERFERENCE AND CONFLICTS PRIOR TO INSTALLATION OF PIPING, VALVES AND EQUIPMENT.
 - F4. WHENEVER THE WORD "PROVIDE" IS USED, IT SHALL MEAN FURNISH AND INSTALL COMPLETE AND READY FOR USE.
 - F5. MODIFY SPRINKLER HEAD LAYOUTS TO ACCOMMODATE RENOVATED AREA NOTED ON DRAWINGS.
 - F6. CONTRACTOR IS REQUIRED TO NOTIFY ENGINEER MINIMUM (7) DAYS PRIOR TO BID IF PROBLEMS EXIST WITH DESIGN OF SPRINKLER SYSTEM.
 - F7. LOCATE NEW AND / OR RELOCATED SPRINKLER HEADS IN CENTER OF CEILING TILES. COORDINATE WITH LIGHTING AND MECHANICAL DIFFUSER LOCATIONS PRIOR TO INSTALLATION TO PREVENT CONFLICTS.
 - F8. SPRINKLER PIPING SHALL BE UL LISTED METALLIC PIPE WITH IDENTIFICATION TO MATCH EXISTING. PIPING SHALL BE SCH 40 FOR SIZES 2" AND SMALLER, THREADED OR ROLL GROOVED. PIPING LARGER THAN 2" SHALL BE MINIMUM SCH 10.
 - F9. SUBMITTALS: CONTRACTOR SHALL SUBMIT DESIGN DOCUMENTS TO TODD GRIFFIN - USC FIRE MARSHAL (803-771-1640) FOR APPROVAL.
 - F10. SPRINKLER HEADS SHALL BE SEMI-RECESSED CHROME PENDENT HEADS TO MATCH EXISTING.
 - F11. REFER TO ARCHITECTURAL DRAWINGS FOR RENOVATED CEILING LAYOUTS AS APPLICABLE.

- SPECIAL NOTES:**
1. EXIST DRAWINGS WERE NOT AVAILABLE AT TIME OF DESIGN FOR THIS PROJECT.
 2. CONTRACTOR IS REQUIRED TO VISIT PROJECT SITE PRIOR TO SUBMITTING BID AND THOROUGHLY FAMILIARIZE HIMSELF WITH ALL EXIST CONDITIONS RELATING TO THIS PROJECT. SUBMISSION OF A BID WILL BE CONSIDERED AS EVIDENCE THAT THE CONTRACTOR HAS VISITED THE SITE OF WORK.



DODIE ANDERSON ACADEMIC ENRICHMENT CENTER
NUTRITION STATION
STATE PROJECT NUMBER: H27-Z302

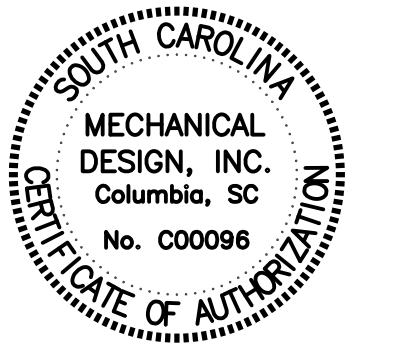
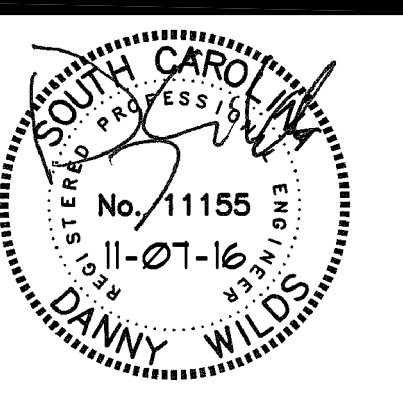

| PHASE: | | |
|--------|------|----------|
| # | DATE | REVISION |
| | | |

SPRINKLER FLOOR PLAN

These drawings are the property of Watson Tate Savory, Inc. and may not be used, copied, or reproduced in any form without the written consent of the architect and the subcontractor. It is intended for the use of the contractor only.

GENERAL "ELECTRICAL" NOTES

- BRANCH CIRCUIT WIRING SHALL BE NO. 12 AWG UNLESS NOTED OTHERWISE. WHERE CONDUCTOR AND RACEWAY SIZE ARE SHOWN AT HOMERUN, SUCH SIZE SHALL BE USED FOR THE ENTIRE CIRCUIT. EXCEPTION: FINAL CONNECTION TO DEVICES, IN OUTLET BOXES, IS NOT REQUIRED TO BE LARGER THAN NO. 12 AWG.
- 20A/120V BRANCH CIRCUITS EXCEEDING 100' IN LENGTH FROM PANEL TO FARTHEST DEVICE OR FIXTURE SHALL USE NO. 10 CONDUCTORS AND 3/4" C.
- PRIOR TO ROUGH-IN, COORDINATE THE LOCATION AND MOUNTING HEIGHT OF ALL WALL AND CEILING MOUNTED DEVICES WITH THE ARCHITECTURAL ELEVATIONS, MILLWORK SHOP DRAWINGS, AND EXISTING CONDITIONS. IN THE EVENT OF A CONFLICT, NOTIFY THE ARCHITECT. MINOR ADJUSTMENTS IN DEVICE LOCATION, I.E. 5'-0" IN ANY DIRECTION SHALL BE DONE AT NO ADDITIONAL COST TO THE OWNER.
- PROVIDE FLEXIBLE CONDUIT FOR ALL CONDUITS CROSSING EXPANSION JOINTS. REFER TO ARCHITECTURAL DRAWINGS FOR LOCATION OF EXPANSION JOINTS.
- OUTLET BOXES FOR SWITCHES, RECEPTACLES, ETC MOUNTED ON OPPOSITE SIDES OF FIRE RATED PARTITIONS SHALL NOT BE SWEATED IN THE SAME WALL CAVITY. SEPARATE WALL PENETRATIONS BY MOUNTING ON OPPOSITE SIDES OF WALL STUDS OR OTHER VERTICAL STRUCTURAL MEMBER IN THE WALL.
- RACEWAYS SHALL BE INSTALLED CONCEALED IN NEW WALL CONSTRUCTION ABOVE CEILINGS, BELOW FLOOR, AND IN OTHER CAVITIES TO THE GREATEST EXTENT POSSIBLE. WHERE EXPOSED RACEWAYS MUST BE USED, LAYOUT RACEWAYS TO MINIMIZE THE NUMBER OF VERTICAL RUNS.
- FEEDER CONDUITS, BRANCH CIRCUITS AND CABLE TRAY ROUTING SHALL COMPLY WITH DETAILS ON DRAWINGS AND SHALL BE COORDINATED WITH THE WORK OF OTHER TRADES BEFORE AND DURING CONSTRUCTION.
- WHERE LIGHT SWITCH AND ABOVE COUNTER RECEPTACLES ARE INDICATED TO BE MOUNTED ADJACENT TO EACH OTHER, THE DEVICES SHALL BE MOUNTED AT THE SAME HEIGHT UNDER A COMMON DEVICE PLATE. REFER TO THE ARCHITECTURAL DRAWINGS FOR PROJECT PHASING.
- THE ARRANGEMENT, GROUPING, AND ROUTING OF BRANCH CIRCUITS SHALL BE PROVIDED AT THE CONTRACTOR'S DISCRETION IN ACCORDANCE WITH GENERALLY ACCEPTED PRACTICE FOR ELECTRICAL WORK, THE NATIONAL ELECTRICAL CODE REQUIREMENTS, LOCAL ORDINANCES, AND THE FOLLOWING:
- A COMMON NEUTRAL MAY BE INSTALLED IN A HOMERUN FOR 2 OR 3 BRANCH CIRCUITS ONLY IF A MEANS TO SIMULTANEOUSLY DISCONNECT ALL UNGROUNDED CONDUCTORS AT THE POINT WHERE THE BRANCH CIRCUITS ORIGINATE IS PROVIDED PER ARTICLE 210.4(B) OF THE NATIONAL ELECTRICAL CODE.
- MULTIPLE SINGLE-POLE BRANCH CIRCUITS (UP TO 3 HOTS, 3 NEUTRALS, 1 GROUND) RATED FOR 30-AMPS OR LESS MAY BE PULLED INTO A SINGLE RACEWAY. THE CONTRACTOR SHALL BE RESPONSIBLE FOR SIZING THE RACEWAYS AND DERATING CONDUCTORS PER NEC ARTICLE 310.15.
- BRANCH CIRCUIT, FEEDER & COMMUNICATION CIRCUITS SHALL BE ROUTED OVERHEAD UNLESS PRIOR APPROVAL HAS BEEN GRANTED BY THE ARCHITECT AND ENGINEER.
- A GROUND CONDUCTOR SHALL BE PROVIDED IN ALL RACEWAYS UNLESS NOTED OTHERWISE.
- THE USE OF MC CABLE IS NOT ALLOWED.
- SEAL ALL EXISTING AND NEW FIRE RATED WALL AND FLOOR PENETRATIONS IN THE CONSTRUCTION AREA
- SEE THE ARCHITECTURAL DRAWINGS FOR ALL LOCATIONS OF FIRE RATED WALLS.
- WHEREVER ON THE ELECTRICAL DRAWINGS THE WORD "PROVIDE" IS USED, IT SHALL BE INFERRED TO MEAN "FURNISH AND INSTALL".
- WHERE CARD READERS AND / OR DOOR CONTACTS ARE SHOWN ON DRAWINGS, COORDINATE WITH ACCESS CONTROL AND DOOR HARDWARE SUPPLIER TO ENSURE THAT ALL RACEWAYS AND BOXES FOR POWER, SIGNALING, AND DATA ARE PROVIDED TO CARD READER LOCATIONS, DOOR FRAME, POWER SUPPLIES, AND CABLE-TRAY.

GENERAL "LIGHTING" NOTES

- SEE ARCHITECTURAL REFLECTED CEILING PLAN FOR THE EXACT LOCATION OF ALL CEILING MOUNTED LIGHTING FIXTURES.
- LIGHTING FIXTURE CATALOG NUMBERS ARE INDICATIVE OF THE STYLE OF FIXTURE REQUIRED. CONTRACTOR SHALL PROVIDE FIXTURES WITH THE PROPER TRIM, VOLTAGE AND OPTIONS NECESSARY FOR INSTALLATION.
- DOUBLE-FACED EXIT FIXTURES SHALL BE OF THE SAME MANUFACTURER & SERIES AS THE SINGLE TYPE SPECIFIED.
- ALL EXIT SIGNS SHALL BE CONNECTED TO LOCAL LIFE SAFETY LIGHTING CIRCUIT AHEAD OF ALL SWITCHING.
- ALL FLUORESCENT FOUR FOOT LIGHT FIXTURES SHALL BE EQUIPPED WITH PROGRAMMABLE START ELECTRONIC BALLASTS.
- WHERE INBOARD/OUTBOARD SWITCHING IS INDICATED, OUTBOARD LAMP(S) SHALL BE KEVED FROM ONE SWITCH AND INBOARD LAMP(S) FROM THE OTHER, THE SWITCH NEAREST THE DOOR SHALL SWITCH THE OUTBOARD LAMPS.
- REFER TO ARCHITECTURAL DRAWINGS FOR MOUNTING DETAILS OF LIGHT FIXTURE TO ACOUSTICAL CEILING SYSTEM AND STRUCTURE.

GENERAL "POWER" NOTES

- ALL BRANCH CIRCUITS INDICATED ON THESE PLANS TO BE LARGER THAN NO. 12 AWG SHALL BE SIZED AS INDICATED FOR THE ENTIRE LENGTH OF THE CIRCUIT.
- WHEN A RECEPTACLE IS INDICATED TO BE MOUNTED ADJACENT TO A COMPUTER/TELEPHONE/ TELEVISION OUTLET, THE DEVICE(S) SHALL BE MOUNTED WITHIN 6" CENTER-TO-CENTER.
- STUB-UP (6) 3/4-INCH SPARE CONDUITS FROM EACH FLUSH MOUNTED PANELBOARD TO ABOVE FINISHED CEILING.
- PROVIDE AND INSTALL AN ENGRAVED LAMINATED PLASTIC NAMEPLATE ON EACH ITEM OF ELECTRICAL EQUIPMENT SERVING MECHANICAL EQUIPMENT WHICH MATCH MECHANICAL DESCRIPTIONS, TO INDICATE THE DESIGNATION OF THE UNIT ON THE PLANS & THE BRANCH CIRCUIT SERVING THE EQUIPMENT.
- PROVIDE NEMA CONFIGURATION RECEPTACLES TO MATCH PLUGS ON EQUIPMENT FURNISHED.
- WHERE SPEED CONTROLLER IS INDICATED TO BE PROVIDED WITH FANS, IT SHALL BE PROVIDED BY MECHANICAL CONTRACTOR AND INSTALLED BY ELECTRICAL CONTRACTOR.
- PROVIDE ENGRAVED FACEPLATES USING 1/8" HIGH BLACK LETTERS ON COVER PLATE OF ALL RECEPTACLES, SWITCHES & WALL MOUNTED DEVICES INDICATING PANEL AND BRANCH CIRCUIT TO WHICH EACH DEVICE IS CONNECTED.

GENERAL "DEMOLITION" NOTES

- ALL ELECTRICAL EQUIPMENT TO BE REMOVED SHALL REMAIN THE PROPERTY OF THE OWNER. THE CONTRACTOR SHALL NOT DISPOSE OF ANY MATERIALS UNTIL RELEASED BY OWNER'S PROJECT MANAGER. MATERIALS THAT OWNER'S PROJECT MANAGER CHOOSES TO RETAIN SHALL BE DELIVERED BY THE CONTRACTOR TO A LOCATION DESIGNATED BY THE PROJECT MANAGER. ALL OTHER MATERIALS SHALL BE PROPERLY DISPOSED OF BY THE CONTRACTOR.
- REMOVE ALL EXPOSED ABANDONED COMMUNICATION CABLE FOUND DURING THE CONSTRUCTION PROCESS. SUPPORT ALL EXISTING REMAINING CABLE PER THE NEC.
- ELECTRICAL DEVICES NOT SHOWN ON WALLS TO BE DEMOLISHED SHALL BE DEMOLISHED AT NO ADDITIONAL COST TO OWNER.
- ELECTRICAL DEVICES NOT SHOWN ON CEILINGS OR WALLS TO REMAIN SHALL REMAIN IN PLACE. PROTECT FROM DAMAGE DURING CONSTRUCTION.
- ELECTRICAL DEVICES NOT SHOWN ON CEILINGS TO BE REMOVED SHALL BE TEMPORARILY DISCONNECTED AND REMOVED DURING DEMOLITION AND RE-INSTALLED ON NEW CEILING IN SAME LOCATION.

GENERAL "SIGNAL" NOTES

- EXTEND A 1" CONDUIT WITH PULL WIRE FROM EACH COMMUNICATIONS OUTLET TO NEAREST CABLE-TRAY OR THE COMMUNICATION BACKBOARD AND TERMINATE WITH AN INSULATED PROTECTIVE BUSHING. COMMUNICATION OUTLET BOX SHALL BE 4" SQUARE WITH SINGLE GANG RING.
- PROVIDE ALL DUCT SMOKE DETECTORS AND ACCESSORIES NECESSARY FOR INTERLOCKING WITH MECHANICAL EQUIPMENT (AHU'S, SMOKE DAMPERS, ETC). COORDINATE WITH MECHANICAL PLANS FOR LOCATIONS AND REQUIREMENTS. DETECTORS SHALL BE FURNISHED BY ELECTRICAL CONTRACTOR, INSTALLED BY MECHANICAL CONTRACTOR, WIRED TO FIRE ALARM SYSTEM BY ELECTRICAL CONTRACTOR, AND TIED TO MECHANICAL CONTROLS FOR AHU SHUTDOWN BY MECHANICAL CONTRACTOR.
- OUTLET BOXES SHALL BE EXTRA DEEP. BOX DEPTH SHALL BE WALL THICKNESS IF POSSIBLE. INDUSTRY STANDARDS SHALL BE USED IF WALL THICKNESS DEPTH IS NOT POSSIBLE
- ALL FIRE ALARM CABLE SHALL BE INSTALLED IN METALLIC CONDUIT. COORDINATES WITH FIRE ALARM SYSTEM MANUFACTURER FOR CABLE ROUTING AND QUANTITIES.
- CABLE SHALL BE CONCEALED IN ALL FINISHED AREAS AND ROUTED PARALLEL OR PERPENDICULAR TO THE BUILDING STRUCTURE.

GENERAL EXISTING CONDITION NOTES

- AREAS OF WORK EXIST FOR THIS PROJECT WHICH ARE NOT ACCESSIBLE OR HAVE LIMITED ACCESS DURING DESIGN. AS SUCH CONTRACTOR SHALL VERIFY ALL UTILITIES IN AREA OF WORK BEFORE DEMOLITION OF ANY SERVICE. ANY ELECTRICAL COMPONENTS NOT SHOWN SHALL BE IDENTIFIED AND THE ARCHITECT AND ENGINEER SHALL BE NOTIFIED AS SOON AS POSSIBLE. NO ELECTRICAL REWORK SHALL BE COMMENCED WITHOUT COORDINATION OF BOTH ARCHITECT AND ENGINEER.
- IN AREAS WHERE THE EXISTING CEILINGS ARE NOT SLATED TO BE REMOVED, THE CONTRACTOR SHALL WORK THRU THE EXISTING CEILINGS (SEE ARCHITECTURAL REFLECTED CEILING PLAN FOR AREA OF WORK). THE CONTRACTOR SHALL BE RESPONSIBLE FOR REPLACING ANY DAMAGED TILE OR GRID THAT IS A RESULT OF THEIR WORK.
- REFER TO ARCHITECTURAL PLANS FOR PHASING OF CONSTRUCTION.
- THE CONTRACTOR SHALL BE RESPONSIBLE FOR INSTALLING A FIRESTOP SYSTEM IN ALL PENETRATIONS OF FIRE-RATED WALLS CREATED BY THE REMOVAL OF EXISTING ELECTRICAL CONDUIT OR CABLES, AS WELL AS THOSE CREATED BY NEWLY INSTALLED CONDUITS AND SLEEVES.
- WHERE INSTALLATION REQUIRES CUTTING OR DRILLING OF THE EXISTING FLOOR SLAB, THE CONTRACTOR SHALL X-RAY THE EXISTING SLAB PRIOR TO WORK TO ENSURE THAT NO EXISTING UTILITIES OR STRUCTURAL ELEMENTS IN THE SLAB WILL BE COMPROMISED BY THE WORK. NOTIFY THE ARCHITECT/ENGINEER OF ANY CONFLICTS THAT WILL REQUIRE RELOCATING THE PROPOSED SLAB WORK. THE CONTRACTOR SHALL BE RESPONSIBLE FOR THE REPAIR OF ANY DAMAGED UTILITIES OR STRUCTURAL ELEMENTS CAUSED BY THE SLAB DEMOLITION.
- SUPPORT ALL EXISTING CONDUITS AND JUNCTION BOXES ABOVE THE CEILING PER NEC IN THE CONSTRUCTION AREA.
- REMOVE ALL ABANDONED CONDUIT, WIRE, AND COMMUNICATION CABLES ABOVE THE CEILING IN THE CONSTRUCTION AREA.
- PROVIDE JUNCTION BOX COVER PLATES ON ALL EXISTING JUNCTION BOXES ABOVE THE CEILING IN THE CONSTRUCTION AREA.
- SUPPORT ALL EXISTING COMMUNICATION CABLES ABOVE THE CEILING IN THE CONSTRUCTION AREA
- WHERE INFORMATION SHOWN ON THESE DRAWINGS CONFLICTS WITH VERIFIED FIELD CONDITIONS, IT SHALL BE BROUGHT TO THE ATTENTION OF THE ENGINEER

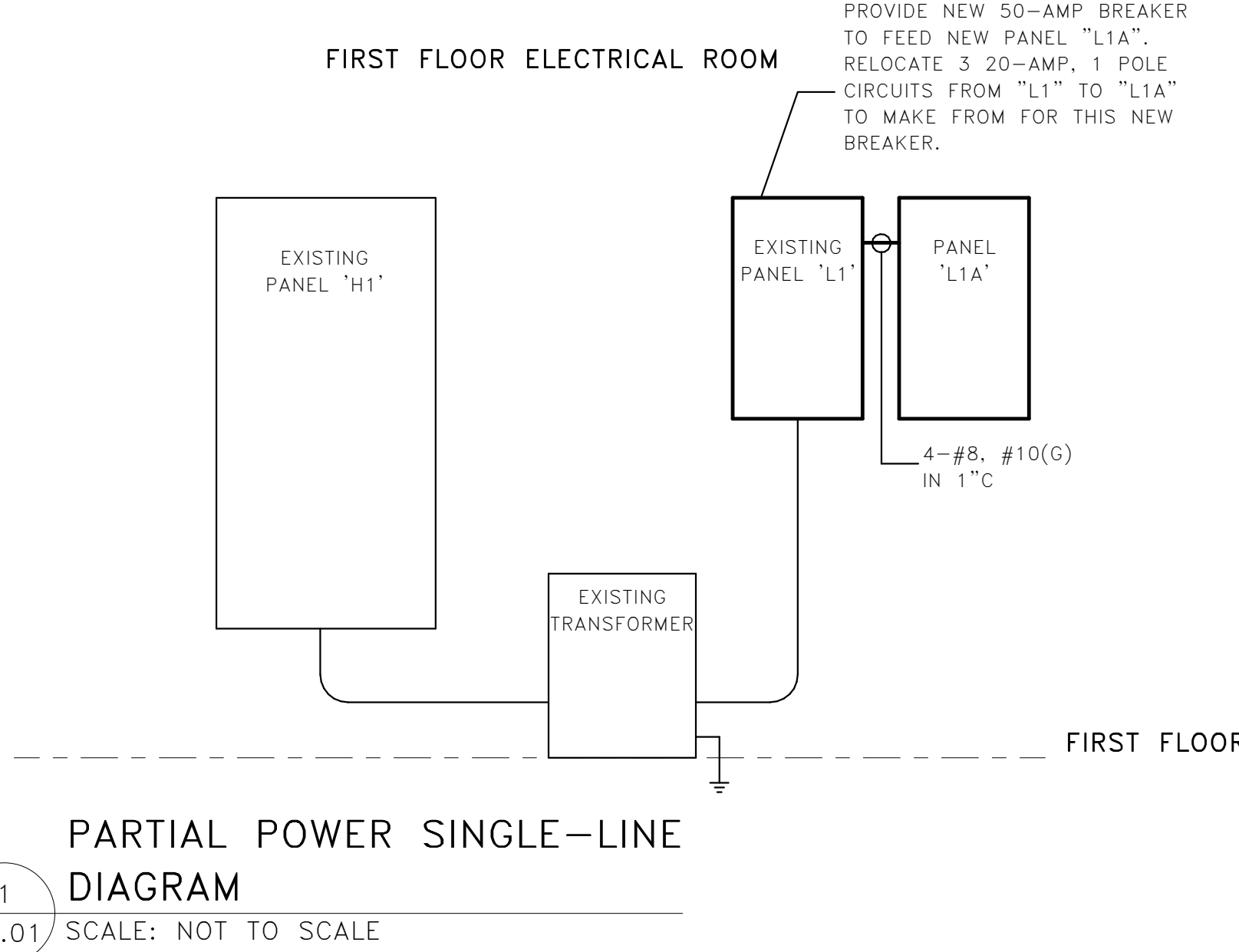

| ELECTRICAL SYMBOL LEGEND | | | |
|--------------------------|---|--------|---|
| SYMBOL | DESCRIPTION | SYMBOL | DESCRIPTION |
| | SINGLE RECEPTACLE (WALL MOUNTED @ 18" AFF) | | OCCUPANCY SENSOR (CEILING MOUNTED) |
| | DUPLEX RECEPTACLE (WALL MOUNTED @ 18" AFF) | | OCCUPANCY SENSOR (WALL MOUNTED) |
| | DUPLEX RECEPTACLE (GFI TYPE @ 18" AFF) | | CONDUIT CALLOUT (# INDICATES DIAMETER) |
| | DUPLEX RECEPTACLE (@ 6" ABOVE COUNTER) | | KEY NOTE CALLOUT (REFER TO KEY NOTES ON SHEET) |
| | DUPLEX RECEPTACLE (GFI TYPE @ 6" ABOVE COUNTER) | | FIRE ALARM PULL STATION (WALL MOUNTED @ 48" AFF TOP OF BOX) |
| | QUAD RECEPTACLE (WALL MOUNTED @ 18" AFF) | | FIRE ALARM AUDIBLE DEVICE (WALL MOUNTED @ 7'-6" AFF) |
| | DUPLEX RECEPTACLE (CEILING MOUNTED) | | FIRE ALARM VISUAL DEVICE (WALL MOUNTED @ 7'-6" AFF) |
| | DUPLEX RECEPTACLE (FLOOR MOUNTED) | | FIRE ALARM SPEAKER/VISUAL DEVICE (WALL MOUNTED @ 7'-6" AFF) |
| | QUADPLEX RECEPTACLE (CEILING MOUNTED) | | FIRE ALARM AUDIBLE DEVICE (CEILING MOUNTED) |
| | QUADPLEX RECEPTACLE (FLOOR MOUNTED) | | FIRE ALARM VISUAL DEVICE (CEILING MOUNTED) |
| | MULTI-PHASE RECEPTACLE (AS NOTED ON PLAN) | | FIRE ALARM SPEAKER/VISUAL DEVICE (CEILING MOUNTED) |
| | JUNCTION BOX (WALL MTD) | | SMOKE DETECTOR (CEILING MOUNTED) |
| | JUNCTION BOX (CEILING) | | HEAT DETECTOR (CEILING MOUNTED) |
| | JUNCTION BOX (FLOOR MOUNTED) | | FIRE / SMOKE DAMPER |
| | PHONE OR DATA OUTLET (WALL MOUNTED @ 18" AFF) | | PRESSURE INDICATING VALVE |
| | PHONE OR DATA OUTLET (MTD ABOVE COUNTER) | | SECURITY CARD READER |
| | PUSH BUTTON CONTROL | | SECURITY KEY PAD |
| | LIGHT SWITCH, SINGLE POLE | | ADDRESSABLE INTERFACE UNIT (MONITOR OR CONTROL TYPE) |
| | LIGHT SWITCH, 3 WAY TYPE | | CABLE TRAY |
| | LIGHT SWITCH, DIMMER TYPE | | PANELBOARD (SURFACE MOUNTED) |
| | LIGHT SWITCH, DIGITALLY TIMED (0-30 MINUTES) | | PANELBOARD (RECESS MOUNTED) |
| | MOTOR RATED SNAP SWITCH IN NEMA 1 ENCLOSURE | | CONTROL PANEL (SURFACE MOUNTED) |
| | LOWER CASE SUBSCRIPT INDICATES SWITCH-LEG | | CONTROL PANEL (RECESS MOUNTED) |
| | MULTI-LEVEL SWITCHING CONFIGURATION | | DISCONNECT SWITCH, (REFER TO EQUIPMENT CONNECTION SCHEDULE) |
| | GENERATOR TRANSFER DEVICE | | DISCONNECT SWITCH, (NON PROTECTED) |
| | | | MOTOR CONNECTION (AS NOTED) |

DEMOLITION/RENOVATION NOTATION

IF NO ANNOTATION IS SHOWN ASSUME EXISTING TO REMAIN IN PLACE FOR SOLID LINES AND DEMOLISH FOR DASHED LINES. DEVICES AND EQUIPMENT NOT SHOWN SHALL BE ASSUMED TO BE EXISTING TO REMAIN IN PLACE.

E EXISTING FIXTURE OR DEVICE TO REMAIN IN PLACE. REPLACE ANY BROKEN DEVICES OR PLATES; COLOR TO MATCH EXISTING.

R EXISTING FIXTURE OR DEVICE TO BE REMOVED BY THE ELECTRICAL CONTRACTOR. MAINTAIN CONTINUITY OF REMAINING PORTIONS OF BRANCH CIRCUIT.

RE EXISTING DEVICE TO BE REMOVED BY THE ELECTRICAL CONTRACTOR. EXISTING CIRCUIT SHALL BE RETAINED. PROVIDE NEW DEVICE AS SHOWN ON RENOVATION PLANS.

RN RELOCATED FIXTURE (NEW LOCATION).

RR EXISTING FIXTURE TO BE RELOCATED BY THE ELECTRICAL CONTRACTOR TO NEW LOCATION SHOWN ON RENOVATION PLAN.

ELECTRICAL DRAWING INDEX

| # | SHEET NAME |
|-------|----------------------------|
| E0.01 | ELECTRICAL NOTES & LEGENDS |
| E1.01 | FIRST FLOOR LIGHTING PLAN |
| E1.02 | FIRST FLOOR POWER PLAN |

ABBREVIATIONS

| ABR | DESCRIPTION |
|------|-----------------------------------|
| AFF | ABOVE FINISHED FLOOR |
| AFG | ABOVE FINISHED GRADE |
| cd | CANDELA |
| EF | EXHAUST FAN |
| FACP | FIRE ALARM CONTROL PANEL |
| GFCI | GROUND-FAULT CIRCUIT-INTERRUPTING |
| GFI | GROUND-FAULT INTERRUPTING |
| IG | ISOLATED GROUND |
| NEC | NATIONAL ELECTRIC CODE |
| SD | SMOKE DETECTOR |
| SPD | SURGE PROTECTION DEVICE |
| WP | WEATHERPROOF |

| PANELBOARD: L1A | | DISTRIBUTION: 120/208 Wye | | A.I.C. RATING: 10,000 | | | | | | | | | | |
|--|-----|------------------------------------|-----|-----------------------|-----|-----|-----|-----|-------------|-------------------------|------------------------------------|-----------------------|-----|--|
| SUPPLIED FROM: L1, 120 V/208 V, Three Phase... | | PHASES: 3 | | MAINS RATING: 250 A | | | | | | | | | | |
| MOUNTING: SURFACE | | WIRES: 4 | | MCB RATING: 225 A | | | | | | | | | | |
| ENCLOSURE: Type 1 | | | | | | | | | | | | | | |
| WIRE SIZE | CKT | DESCRIPTION | BKR | P | A | C | P | BKR | DESCRIPTION | CKT | WIRE SIZE | | | |
| | 1 | RECP. - TVS | 20 | 1 | 1.0 | 0.4 | | 1 | 20 | RECP. - COUNTER TOP | 2 | | | |
| | 3 | * RECP. - BEVERAGE CASE | 20 | 1 | | 0.2 | 0.2 | 1 | 20 | * RECP. - BEVERAGE CASE | 4 | | | |
| | 5 | RECP. - BLENDER | 20 | 1 | | | 0.2 | 0.2 | 1 | 20 | RECP. - BLENDER | 6 | | |
| | 7 | RECP. - BLENDER | 20 | 1 | 0.2 | 0.2 | | | 1 | 20 | RECP. - BLENDER | 8 | | |
| | 9 | * JBOX - UC DISPOSAL | 20 | 1 | | 0.1 | 0.0 | | 1 | 20 | RELOCATED CIRCUITS FROM PANEL "L1" | 10 | --- | |
| | 11 | RELOCATED CIRCUITS FROM PANEL "L1" | 20 | 1 | | | 0.0 | 0.0 | 1 | 20 | RELOCATED CIRCUITS FROM PANEL "L1" | 12 | --- | |
| | 13 | SPARE | 20 | 1 | 0.0 | 0.0 | | | 1 | 20 | SPARE | 14 | --- | |
| | 15 | SPARE | 20 | 1 | | 0.0 | 0.0 | | 1 | 20 | SPARE | 16 | --- | |
| | 17 | SPARE | 20 | 1 | | | 0.0 | 0.0 | 1 | 20 | SPARE | 18 | --- | |
| | 19 | SPARE | 20 | 1 | 0.0 | 0.0 | | | 1 | 20 | SPARE | 20 | --- | |
| | 21 | SPARE | 20 | 1 | | 0.0 | 0.0 | | 1 | 20 | SPARE | 22 | --- | |
| | 23 | SPARE | 20 | 1 | | | 0.0 | 0.0 | 1 | 20 | SPARE | 24 | --- | |
| TOTAL PER PHASE KVA: | | | 1.7 | | | 0.5 | | | 0.4 | | | CONNECTED KVA: 2.5 | | |
| TOTAL PER PHASE AMPACITY: | | | 14 | | | 4 | | | 3 | | | CONNECTED AMPACITY: 7 | | |

NOTES:

- GFCI TYPE BREAKER

ARCHITECTURE
INTERIORS
PLANNING

WTS
WATSON TATE SAVORY



DODIE ANDERSON ACADEMIC ENRICHMENT CENTER
NUTRITION STATION
STATE PROJECT NUMBER: H27-2302

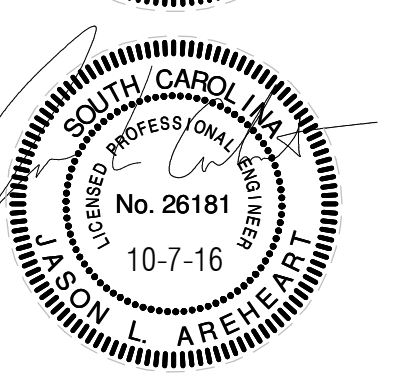
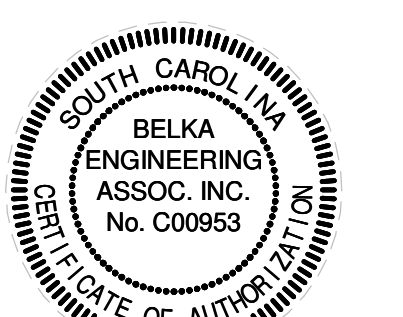

| PHASE: | SCHEMATIC DESIGN | |
|--------|------------------|----------|
| # | DATE | REVISION |
| | | |
| | | |
| | | |
| | | |
| | | |
| | | |
| | | |

ELECTRICAL
NOTES &
LEGENDS

11/4/16
ISSUE DATE
WT21603
PROJECT NO.

E0.01

SHEET NO.

WT21603

BEA BELKA ENGINEERING ASSOCIATES, INC.

CONTACT: JASON AREHEART
7 CLUSTERS COURT, SUITE 201 | COLUMBIA, SC | 29210
(803) 731-0650 p | (803) 731-2880 f
JAREHEART@BEA-Consulting.com

C:\Users\jareh\Documents\WT21603_DODIE NUTRITION CENTER_2017_0808.rvt 11/2/2016 4:02:25 PM

These drawings are the property of Watson Tate Savory, Inc. and may not be used in whole or in part without written consent of the architect and any infringement is subject to legal action.

| LIGHT FIXTURE SCHEDULE | | | | | | | | | | |
|------------------------|------------------------|------------------------|---------------|-------------------------------|---------|----------------------|------------|-------|----------------------------------|---------|
| SYMBOL | FIXTURE SPECIFICATIONS | | | | LAMPING | | ELECTRICAL | | MOUNTING REMARKS | NOTES |
| | TYPE | FIXTURE DESCRIPTION | MANUFACTURER | CAT. # | NO. | LAMP TYPE | FIXT. LOAD | VOLTS | | |
| | A | FLUORESCENT 2X4 | H.E. WILLIAMS | LPT-24-332-SA12125-EB 3-UNV | 3 | T8, 840 | 96 | 277 V | RECESSED IN CEILING | 2,3,4 |
| | AE | FLUORESCENT 2X4 | H.E. WILLIAMS | LPT-24-332-SA12125-EB 3-UNV | 3 | T8, 840 | 96 | 277 V | RECESSED IN CEILING | 2,3,4 |
| | B | LED LINEAR | FINELITE | HP-2R-12-S-8-40-F-2 77V-SC-SF | - | LED, 4032 LUMENS 840 | 43 | 277 V | RECESSED IN CEILING | 1,2,3,4 |
| | C | ANGLED LED LINEAR (5') | LUMINI | PSV-96-24-UZDIM-D | - | LED, 1265 LUMENS 835 | 16 | 277 V | SURFACE MOUNTED ON TOP OF CANOPY | 1,2,3,4 |

LIGHT FIXTURE SCHEDULE NOTES

- LUMENS LISTED IN SCHEDULE REPRESENT DELIVERED LUMENS OF FIXTURES.
- THREE DIGIT NUMBERS LISTED IN LAMP COLUMN REPRESENT CRI AND COLOR TEMPERATURE. FIRST DIGIT INDICATES MINIMUM CRI AND LAST TWO DIGITS INDICATE COLOR TEMPERATURE. EXAMPLE: 830 INDICATES MINIMUM CRI OF 80 AND A COLOR TEMPERATURE OF 3000K.
- SEE ARCHITECTURAL RCP AND ELEVATIONS FOR EXACT LOCATION AND MOUNTING HEIGHTS.
- CONFIRM QUANTITIES OF FIXTURES SHOWN IN RCP MATCH QUANTITIES SHOWN ON ELECTRICAL PLANS PRIOR TO BID. IF NO DISCREPANCIES ARE NOTED PRIOR TO BID THE HIGHEST QUANTITY OF EACH FIXTURE TYPE SHOWN SHALL BE PROVIDED.

LIGHT FIXTURE PLAN KEY

SHADING INDICATES EMERGENCY FIXTURE USED BY GENERATOR

CE d = UPPER CASE LETTER / LETTERS INDICATE FIXTURE TYPE
 d = LOWER CASE LETTER INDICATES SWITCH IDENTIFICATION
 NL or EM = INDICATES NON SWITCHED "NIGHT LIGHT" / "EMERGENCY"
 A-9 = DESIGNATES PANEL NAME: CIRCUIT NUMBER

NOTE:
 ALL "EM" FIXTURES INDICATED IN PLAN CONTAIN CONNECTION TO GENERATOR. WHERE GTD OR GTD-20 IS SHOWN, CONNECT EMERGENCY FIXTURES THROUGH GTD WITH A GENERATOR-BACKED (CONSTANT HOT) CIRCUIT AND THE NORMAL POWER SWITCHLEG ASSOCIATED WITH THAT SPACE SO THAT FIXTURE IS CONTROLLED WITH NORMAL FIXTURES BUT TRANSFER TO GENERATOR CIRCUIT AT 100% OUTPUT DURING AN OUTAGE.

KEY NOTES

- PROVIDE REMOTE POWER SUPPLY FOR TYPE "C" FIXTURES MOUNT ABOVE ACCESSIBLE CEILING IN THIS LOCATION.
- CONNECT TO EXISTING NORMAL POWER LIGHTING CIRCUIT IN EXISTING CORRIDOR, (H1-6). BYPASS ALL EXISTING SWITCHLEGS AND CONNECT THROUGH DIMMER.
- CONNECT TO EXISTING EMERGENCY POWER LIGHTING CIRCUIT IN EXISTING CORRIDOR, (LHB-14). BYPASS ALL EXISTING SWITCHLEGS AND CONNECT THROUGH GTD.
- EXTEND EXISTING BRANCH CIRCUIT TO RELOCATED FIXTURE.

ARCHITECTURE
 INTERIORS
 PLANNING

WTS
 WATSON TATE SAVORY



DODIE ANDERSON ACADEMIC ENRICHMENT CENTER
 NUTRITION STATION
 STATE PROJECT NUMBER: H27-Z302

GENERAL NOTES

- ALL NORMAL POWER LIGHTING SHOWN ON THIS PLAN IS SERVED FROM PANEL "H1" UNLESS NOTED OTHERWISE.
- ALL EMERGENCY POWER LIGHTING ON THIS PLAN IS SERVED FROM PANEL "LHB" UNLESS OTHERWISE NOTED.



90 FIRST FLOOR LIGHTING DEMOLITION PLAN
 E1.01 SCALE: 1/4" = 1'-0"

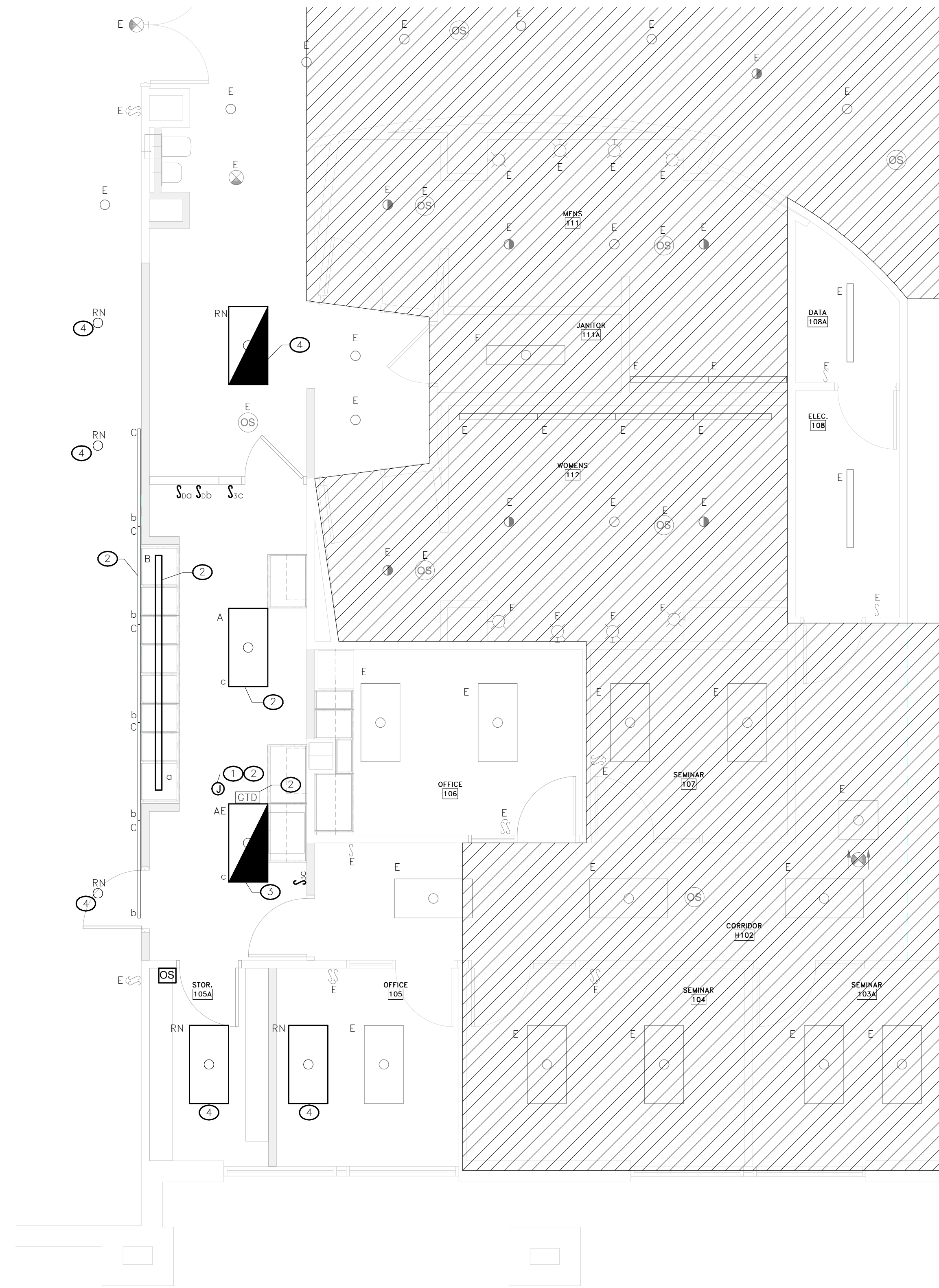

3 FIRST FLOOR LIGHTING RENOVATION PLAN
 E1.01 SCALE: 1/4" = 1'-0"

WT21603

BEA BELKA ENGINEERING ASSOCIATES, INC.
 CONTACT: JASON AREHEART
 7 CLUSTERS COURT, SUITE 201 | COLUMBIA, SC | 29210
 (803) 731-0650 p | (803) 731-2880 f
 JAREHEART@BEA-Consulting.com

FIRST FLOOR LIGHTING PLAN

11/4/16
 ISSUE DATE
 WT21603
 PROJECT NO.

E1.01
 SHEET NO.

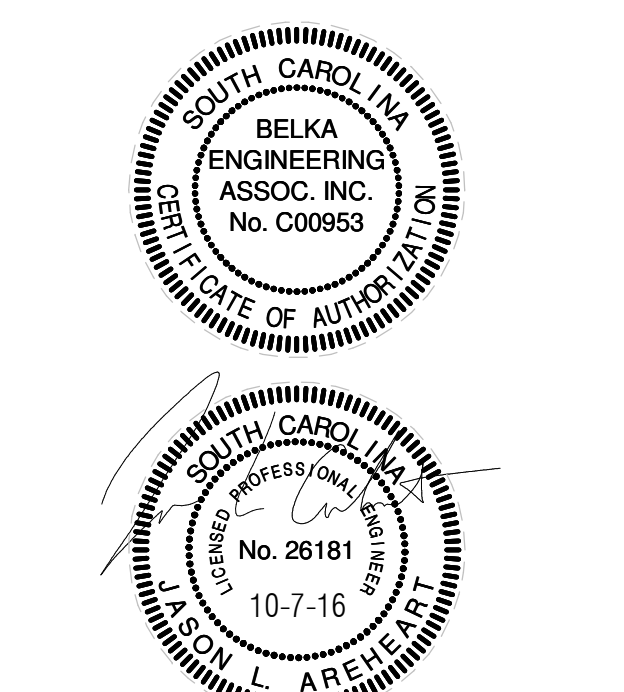

| | | |
|--------|------------------|----------|
| PHASE: | SCHEMATIC DESIGN | |
| # | DATE | REVISION |
| | | |
| | | |
| | | |
| | | |

11/7/2016 4:52:25 PM C:\Users\Jason\Documents\WT21603_DODIE NUTRITION CENTER_2017_0000.rvt

These drawings are the property of Watson Tate Savory, Inc. and may not be used in whole or in part without written consent of the architect and any infringement is subject to legal action.

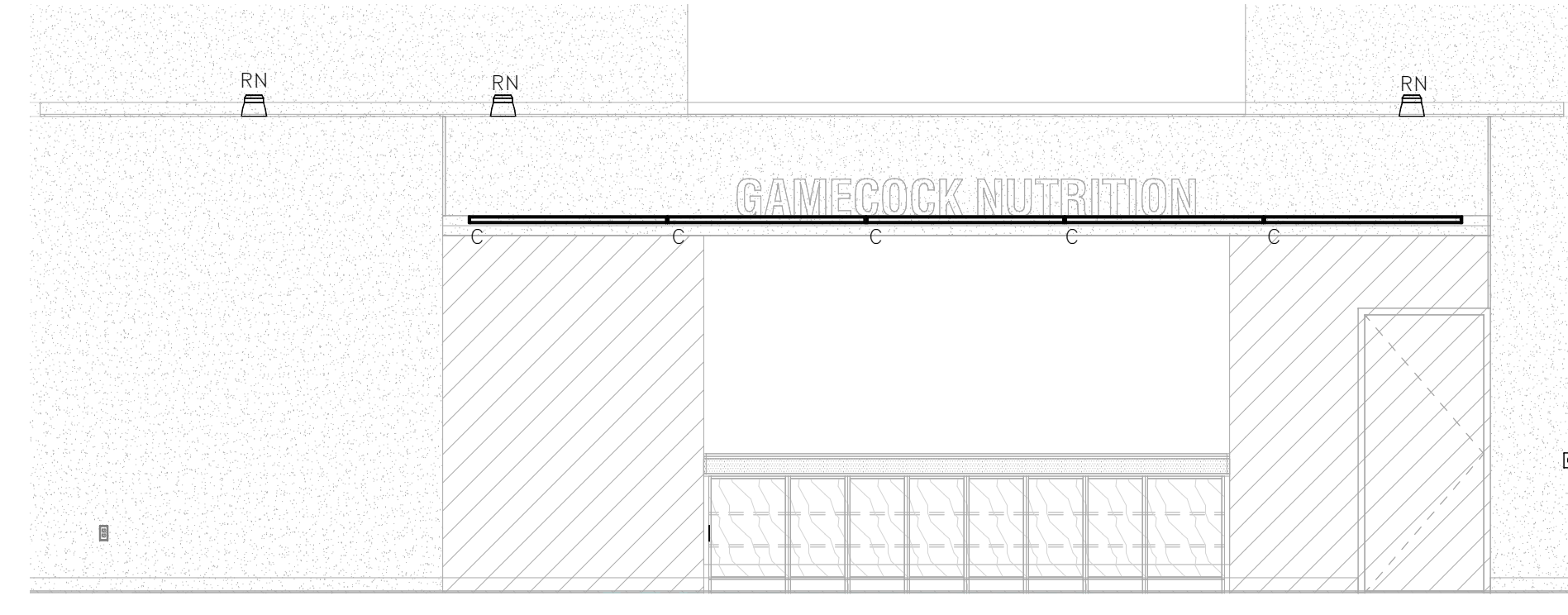

3 NUTRITION BAR SERVING COUNTER ELEVATION
E1.02 SCALE: 1/4" = 1'-0"



4 NUTRITION BAR PREP AREA ELEVATION
E1.02 SCALE: 1/4" = 1'-0"

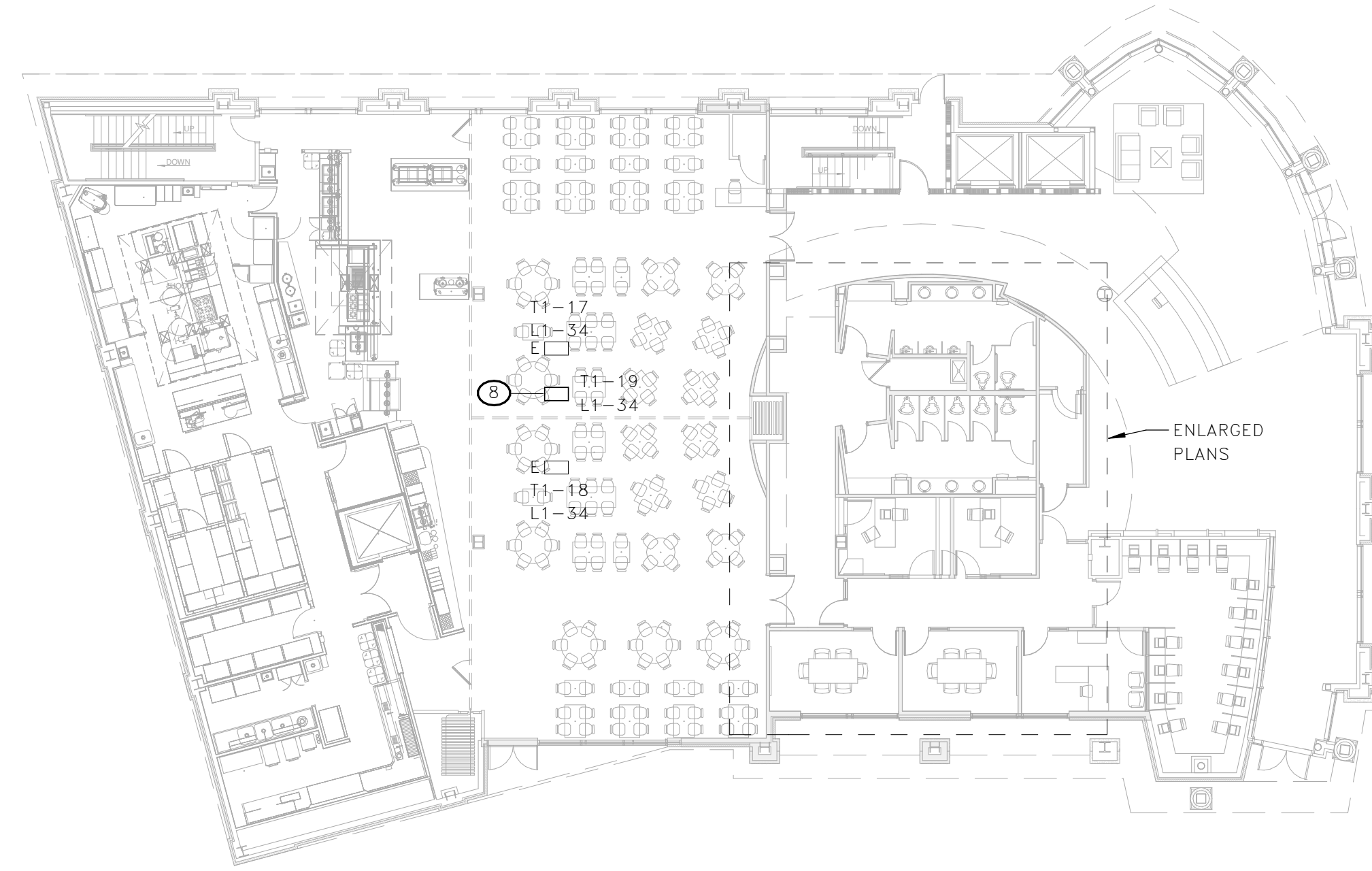

5 OVERALL FIRST FLOOR POWER PLAN
E1.02 SCALE: 1/16" = 1'-0"

KEY NOTES

- COORDINATE LOCATION OF NEW WALL WITH OWNER/ARCHITECT TO ENSURE NO CONFLICT WITH EXISTING FLOORBOX.
- COORDINATE EXACT LOCATION OF UNDER COUNTER REFRIGERATOR WITH ARCH/OWNER AND LOCATE RECEPTACLE IN A LOCATION THAT IS ACCESSIBLE WITHOUT REMOVING APPLIANCE.
- EXISTING TV SHALL BE RELOCATED TO NEW LOCATION SHOWN ON RENOVATION PLAN REFERENCED TO KEY NOTE 4. EXISTING BRANCH CIRCUIT SHALL BE EXTENDED TO NEW LOCATION. COORDINATE WITH OWNER FOR A/V SYSTEM MODIFICATION. EXTEND EXISTING RACEWAYS FOR LOW-VOLTAGE CABLING TO NEW LOCATION.
- PROVIDE A CHIEF (MODEL: PAC526) RECESSED WALL BOX WITH DUPLEX RECEPTACLE MOUNTED INTEGRAL TO BOX. COORDINATE EXACT MOUNTING LOCATIION WITH ARCHITECT / OWNER PRIOR TO ROUGH-IN. CONNECT TO EXISTING BRANCH CIRCUIT REFERENCED IN KEYED NOTE 3. EXISTING LOW-VOLTAGE RACEWAYS SHALL BE EXTEND TO THIS BOX.
- EXISTING TV HAS HDMI CONNECTION FROM OFFICE 106. EXISTING TV SHALL BE REMOVED BY OWNER. DISCONNECT AND REMOVE EXISTING POWER AND A/V SYSTEM CABLING COMPLETELY BACK TO SOURCE.
- PROVIDE AN A/V WALL BOX (CHIEF MODEL: PAC526) RECESSED WALL BOX WITH DUPLEX RECEPTACLE MOUNTED INTEGRAL TO BOX. PROVIDE A 1-1/4" CONDUIT FROM A/V WALL BOX TO A 4" SQUARE BOX MOUNTED NEAR COMPUTER WORKSTATION IN OFFICE 106. PROVIDE ANOTHER 1-1/4" CONDUIT FROM A/V WALL BOX TO CABLE-TRAY FOR ANY FUTURE A/V REQUIREMENTS.
- RELOCATE EXISTING WALL SWITCH FOR PROJECTION SCREEN TO LOCATION SHOWN ON RENOVATION PLAN REFERENCED TO THIS NOTE.
- EXTEND EXISTING BRANCH CIRCUIT "L1-34" FROM EXISTING YAV-T1-17 TO NEW YAV-T1-19 LOCATION. SEE MECHANICAL PLANS FOR EXACT LOCATION.
- CHANGE CANDELA RATING ON EXISTING WALL MOUNT SPEAKER/STROBE TO 110cd. CONFIRM CIRCUIT MEETS ALL VOLTAGE DROP AND BATTERY REQUIREMENTS.
- RELOCATE EXISTING BRANCH CIRCUIT TO NEW LOCATION OF WATER FOUNTAIN.
- EXTEND EXISTING BRANCH CIRCUIT IN OFFICE 105 TO NEW RECEPTACLE LOCATION.
- EXTEND EXISTING BRANCH CIRCUIT THAT FEEDS EXISTING UC REFRIGERATOR TO NEW UC REFRIGERATOR LOCATION.

GENERAL NOTES

- BRANCH CIRCUITS SHOWN ON THIS SHEET SHALL SERVED FROM PANEL "L1A" UNLESS NOTED OTHERWISE.



1 ENLARGED POWER DEMOLITION PLAN
E1.02 SCALE: 1/4" = 1'-0"

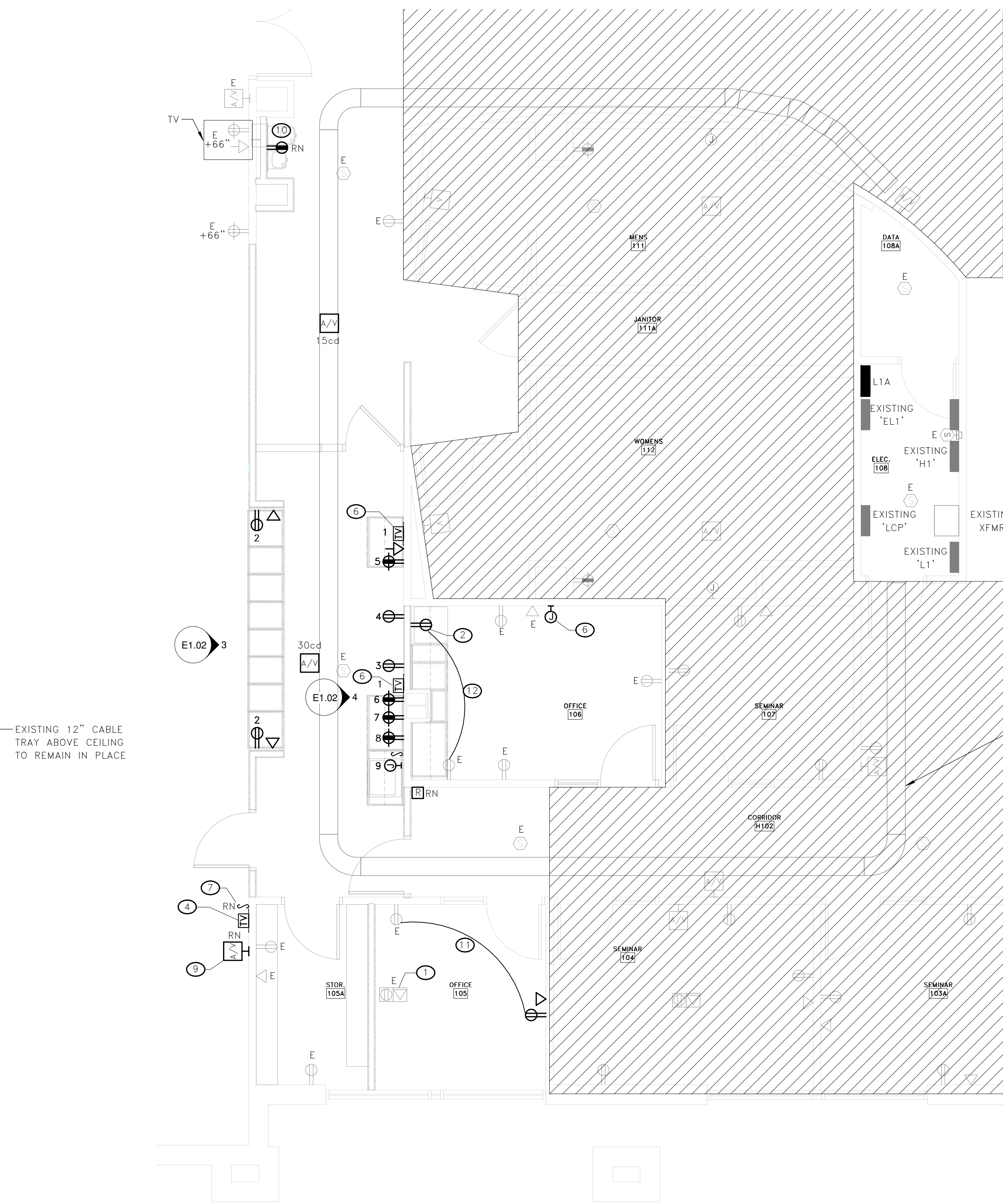

2 ENLARGED POWER RENOVATION PLAN
E1.02 SCALE: 1/4" = 1'-0"

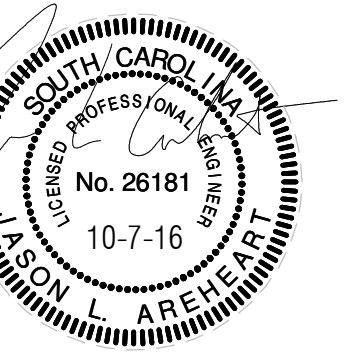
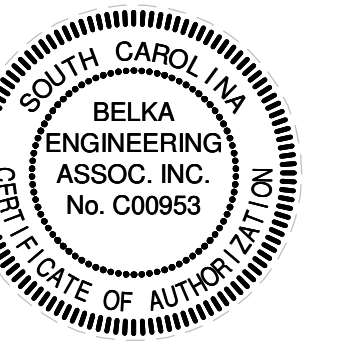

PHASE: SCHEMATIC DESIGN

| # | DATE | REVISION |
|---|------|----------|
| | | |
| | | |
| | | |
| | | |
| | | |
| | | |
| | | |
| | | |
| | | |
| | | |

BEA BELKA ENGINEERING ASSOCIATES, INC.
CONTACT: JASON AREHEART
7 CLUSTERS COURT, SUITE 201 | COLUMBIA, SC | 29210
(803) 731-0650 p | (803) 731-2880 f
JAREHEART@BEA-Consulting.com

11/7/2016 4:42:29 PM C:\Users\Jason\Documents\WT21603_DODIE NUTRITION_CENTRAL_2017_0000.rvt