



Request for Quotation

Page One

THIS IS NOT AN ORDER

Purchasing Department | 1600 Hampton Street, Suite 606 | Columbia, SC 29208 | (803) 777-4115

Quotation must be received no later than: 2:00 PM	Send Quotation to above address at Attention of:	Solicitation Number:	Posting Date:
06 28 2016		USC-RFQ-2987-KS	06 15 2016

Questions regarding this solicitation must be received no later than **06.23.2016 12:00 Noon**. Answers to vendor questions will be posted to the Purchasing Department's website in an amendment to the solicitation: purchasing.sc.edu/sa.php

Please quote your lowest delivered price of the item(s) listed below. The Purchasing Department reserves the right to reject any or all quotes and to waive any or all technicalities. All Quotes must be signed by the vendor's representative per the terms noted. Failure to comply with these instructions may result in disqualification of the quote. Faxed or E-mailed Quotes are acceptable and preferred. This solicitation conforms to the provisions of Procurement Code Section 11-35-1550.

Vendor Name and Address: _____

Phone Number: _____ E-mail: _____

FEIN / SSN: _____ SC Minority Cert. No. : _____

Print Name: _____ Signature: _____

Item	Unit	Description of Supplies	Total Price
1	ea	Mandrel as specified	\$
		Award to be made to one vendor for entire lot.	
		Quote only as specified. Do not include sales tax.	
		Deliveries shall be FOB Destination, freight prepaid.	
		A faxed or e-mailed quote is acceptable.	
		Buyer: Kevin Sanders	
		Phone: (803) 777-4115	
		E-mail: ksanders@mailbox.sc.edu	

TERMS AND CONDITIONS

All amendments to and interpretation of this RFQ shall be in writing. The procurement officer shall not be legally bound by any amendment or interpretation that is not in writing.

Any contract entered into by the University of South Carolina or its agencies resulting from this quotation shall be subject to cancellation at the end of any fiscal or appropriated year unless otherwise provided by law.

Payment will be made in accordance with Section 11-35-45 of the South Carolina Consolidated Procurement Code and Disbursement Regulations. Delay in receiving invoices, as well as errors and omissions on the invoices, will be considered just cause for withholding payment without losing discount privileges. The University reserves the right to withhold payment or make such deductions as may be necessary to protect the University from loss or damage because of defective work, claims, damages, or to pay for repair or correction of materials furnished hereunder.

Quoted prices must remain firm for a period of thirty days beyond the Request for Quotation deadline. Unit prices will govern over extended prices unless otherwise stated.

All materials and products offered must be guaranteed to meet and comply with the requirements of all specifications, terms, and conditions indicated in this solicitation.

Award will be made in accordance with Section 11-35-1550 of the South Carolina Consolidated Procurement Code.

The University reserves the right to: (1) reject any and all quotations and to cancel the solicitation; (2) waive any and all technicalities; (3) reject any quotation in which the delivery time indicated is of substantial length to cause disruption and/or delay in operation for which the item(s) is/are intended; (4) reject ambiguous quotations which are uncertain as to terms, delivery, quantity, or compliance with specifications.

The successful bidder assumes sole responsibility and shall hold harmless the University of South Carolina, its directors, officers, employees, and agents from and against any and all claims, actions, or liabilities of any nature which may be asserted against them by third parties in connection with the performance of the successful bidder, its directors, officers, employees, and agents under this agreement. The University of South Carolina agrees to accept responsibility for claims, actions, or liabilities resulting from negligent acts of its employees occurring within the scope of their employment which may be asserted against them by third parties in connection with the performance of the University of South Carolina, its members, directors, officers, employees, and agents under this agreement.

Contractor agrees not to refer to award of this contract in commercial advertising in such a manner to state or imply that the products or service provided are endorsed or preferred by the user.

Upon award of a contract under this solicitation, the person, partnership, association, or corporation to whom the award is made must comply with the laws of South Carolina that require such person or entity to be authorized and/or licensed to do business in this State. Notwithstanding the fact that applicable statutes may be exempt or exclude the successful offeror from requirements that it be authorized and/or licensed to do business in this State, by submission of this signed quote, the quoter agrees to subject itself to the jurisdiction and process of the courts of the State of South Carolina as to all matters and disputes arising or to arise under the contract and the performance thereof, including any questions as to the liability for taxes, licenses, or fees levied by the State.

The University of South Carolina requires all contractual activities to be performed in a manner that is consistent with all applicable federal, state and local laws, regulations, rules, rulings, and ordinances.

These include, but are not limited to: the Occupational safety and Health Act, The Environmental Protection Act, The South Carolina Hazardous Waste Management Act.

QUESTIONS FROM OFFERORS

Any prospective offeror desiring an explanation or interpretation of the solicitation, drawings, specifications, etc., must request it in writing. Questions must be received by the Procurement Officer no later than **05.05.16, 12:00 Noon**. Label any communication regarding your questions with the name of the procurement officer, and the solicitation's title and number. Oral explanations or instructions will not be binding. Any information given a prospective offeror concerning a solicitation will be furnished promptly to all other prospective offerors as an Amendment to the solicitation if that information is necessary for submitting offers or if the lack of it would be prejudicial to other prospective offerors. The State seeks to permit maximum practicable competition. Offerors are urged to advise the Procurement Officer as soon as possible regarding any aspect of this procurement, including any aspect of the Solicitation that unnecessarily or inappropriately limits full and open competition.

Information for Submitting Questions

Buyer: Kevin Sanders

Solicitation: USC-RFQ-2964-KS

Title: Steam Water Heater

E-mail Address: ksanders@mailbox.sc.edu

Fax Number: (803)777-2032

DEFAULT

The state may terminate this contract, or any part hereof, for cause in the event of any default by the contractor, or if the contractor fails to comply with any contract terms and conditions, or fails to provide the state, upon request, with adequate assurances of future performance. In the event of termination for cause, the state shall not be liable to the contractor for any amount for supplies or services not accepted, and the contractor shall be liable to the state for any and all rights and remedies provided by law. If it is determined that the state improperly terminated this contract for default, such termination shall be deemed a termination for convenience. In case of default by the contractor, the University of South Carolina reserves the right to purchase any or all items in default in the open market, charging the contractor with any additional costs. The defaulting contractor shall not be considered a responsible bidder until the assessed charge has been satisfied.

TERMINATION FOR CONVENIENCE – SHORT FORM (JAN 2006)

The Procurement Officer may terminate this contract in whole or in part, for the convenience of the State. In such a termination, the Procurement Officer may require the contractor to transfer title and deliver to the State in the manner and to the extent directed by the Procurement Officer: (a) any completed supplies; and (b) such partially completed supplies and materials, parts, tools, dies, jigs, fixtures, plans, drawings, information, and contract rights (hereinafter called "manufacturing material") as the contractor has specifically produced or specially acquired for the performance of the terminated part of this contract. Upon such termination, the contractor shall (a) stop work to the extent specified, (b) terminate any subcontracts as they relate to the terminated work, and (c) be paid the following amounts without duplication, subject to the other terms of this contract: (i) contract prices for supplies or services accepted under the contract, (ii) costs incurred in performing the terminated portion of the work, and (iii) any other reasonable costs that the contractor can demonstrate to the satisfaction of the State, using its standard record keeping system, have resulted from the termination. The contractor shall not be paid for any work performed or costs incurred that reasonably could have been avoided. As a condition of payment, contractor shall submit within three months of the effective date of the termination a claim specifying the amounts due because of the termination. The absence of an appropriate termination for convenience clause in any subcontract shall not increase the obligation of the state beyond what it would have been had the subcontract contained such a clause.

PREFERENCES – A NOTICE TO VENDORS (SEP 2009)

On June 16, 2009, the South Carolina General Assembly rewrote the law governing preferences available to in-state vendors, vendors using in-state subcontractors, and vendors selling in-state or US end products. This law appears in Section 11-35-1524 of the South Carolina Code of Laws. A summary of the new preferences is available at www.procurement.sc.gov/preferences. ALL THE PREFERENCES MUST BE CLAIMED AND ARE APPLIED BY LINE ITEM, REGARDLESS OF WHETHER AWARD IS MADE BY ITEM OR LOT. VENDORS ARE CAUTIONED TO CAREFULLY REVIEW THE STATUTE BEFORE CLAIMING ANY PREFERENCES. THE REQUIREMENTS TO QUALIFY HAVE CHANGED. IF YOU REQUEST A PREFERENCE, YOU ARE CERTIFYING THAT YOUR OFFER QUALIFIES FOR THE PREFERENCE YOU'VE CLAIMED. IMPROPERLY REQUESTING A PREFERENCE CAN HAVE SERIOUS CONSEQUENCES. [11-35-1524(E)(4)&(6)]

PREFERENCES – SC/US END PRODUCT (SEP 2009)

Section 11-35-1524 provides a preference to vendors offering South Carolina end-products or US end-products, if those products are made, manufactured, or grown in SC or the US, respectively. An end-product is the tangible project identified for acquisition in this solicitation, including all component parts in final form and ready for the use intended. The terms "made," "manufactured," and "grown" are defined by Section 11-35-1524(A). By signing your offer and checking the appropriate space(s) provided and identified on the bid schedule, you certify that the end-product(s) is either made, manufactured or grown in South Carolina, or other states of the United States, as applicable. Preference will be applied as required by law. Post award substitutions are prohibited. See "Substitutions Prohibited - End Product Preferences (Sep 2009)" provision.

PREFERENCES – RESIDENT VENDOR PREFERENCE (SEP 2009)

To qualify for the RVP, you must maintain an office in this state. An office is a nonmobile place for the regular transaction of business or performance of a particular service which has been operated as such by the bidder for at least one year before the bid opening and during that year the place has been staffed for at least fifty weeks by at least two employees for at least thirty five hours a week each. In addition, you must either: (1) maintain at a location in South Carolina at the time of the bid an inventory of expendable items which are representative of the general type of commodities for which the award will be made and which have a minimum total value, based on the bid price, equal to the lesser of fifty thousand dollars [\$50,000] or the annual amount of the contract; or (2) be a manufacturer headquartered and having an annual payroll of at least one million dollars in South Carolina and the end product being sold is either made or processed from raw materials into a finished end product by that manufacturer or its affiliate (as defined in Section 1563 of the Internal Revenue Code).

PREFERENCES – BID SCHEDULE

All preferences must be claimed by initialing in the space provided in the bid schedule. Preferences are applied by line item whether the award is to be made by line item or lot. If you request a preference, you are certifying that your offer qualifies for the preference you have claimed. If you qualify for a preference but do not request it, you are not entitled to receive preference applications per 11-35-1524.

SUBSTITUTIONS PROHIBITED – END PRODUCT PREFERENCES (SEP 2009)

If you receive the award as a result of the South Carolina end product or United States end product preference, you may not substitute a nonqualifying end product for a qualified end product. If you violate this provision, the State may terminate your contract for cause and you may be debarred. In addition, you shall pay to the State an amount equal to twice the difference between the price paid by the State and your evaluated price for the item for which you delivered a substitute. [11-35-1524(B)(4)]

SHIPPING / RISK OF LOSS

FOB Destination. Destination is the shipping dock of the University of South Carolina's designated receiving site, or other location, as specified herein.

IRAN DIVESTMENT ACT – CERTIFICATION (JAN 2015)

(a) The Iran Divestment Act List is a list published by the Board pursuant to Section 11-57-310 that identifies persons engaged in investment activities in Iran. Currently, the list is available at the following URL: <http://procurement.sc.gov/PS/PS-iran-divestment.phtm>. Section 11-57-310 requires the government to provide a person ninety days written notice before he is included on the list. The following representation, which is required by Section 11-57-330(A), is a material inducement for the State to award a contract to you. (b) By signing your Offer, you certify that, as of the date you sign, you are not on the then-current version of the Iran Divestment Act List. (c) You must notify the Procurement Officer immediately if, at any time before posting of a final statement of award, you are added to the Iran Divestment Act List.

HIPAA LAW

The Contractor agrees that to the extent that some or all of the activities within the scope of this Contract are subject to the Health Insurance Portability Accountability Act of 1996, P.L. 104-91, as amended (“HIPAA”), or its implementing regulations, it will comply with the HIPAA requirements and will execute such agreements and practices as the University of South Carolina may require to ensure compliance. Additional information may be viewed at: <http://www.sa.sc.edu/shs/hipaa/>

PROTECTION OF HUMAN HEALTH AND THE ENVIRONMENT

The University of South Carolina requires that all contractual activities to be in compliance with local, state and federal mandates concerning “protection of human health and the environment”. In addition, the University of South Carolina is a “Drug Free Work Place” and requires all contractors to comply with South Carolina Code of Laws Section 41-15-10 ET sequence (1976 w/amendments). Any contractor doing business with the University will be required to document compliance with these mandates and to furnish specific information requested by the University’s Department of Environmental Health and Safety when notified to do so. The Contractor understands and agrees that jobsites are open at all times work is being performed by the Contractor to authorized University employees who have been trained to identify unsafe work conditions. The Contractor will immediately correct any deficiencies noted by these inspections when requested by the University’s Department of Environmental Health and Safety to do so. In work areas where a specific hazard is posed which includes but is not limited to lead paint and asbestos abatement projects, Contractors will be required to produce Lead Compliance Plans and Asbestos Project Designs which outline their method of work prior to the start of work. Each contractor shall designate a responsible member of the Contractor’s organization to be at the site whose duty shall be the prevention of accidents. By submission of this bid, the vendor agrees to take all necessary steps to insure compliance with the requirements outlined above.

RELATIONSHIP OF THE PARTIES (JAN 2006)

Neither party is an employee, agent, partner, or joint venturer of the other. Neither party has the right or ability to bind the other to any agreement with a third party or to incur any obligation or liability on behalf of the other party.

VENDOR IDENTIFICATION

The University must have your Federal ID Number (company) or Social Security Number (individual) before processing any invoices for payment. Failure to provide this information will result in delay of payments until this information is received. Please include this information with your quote.

WARRANTY - STANDARD (JAN 2006)

Contractor must provide the manufacture’s standard written warranty upon delivery of product. Contractor warrants that manufacturer will honor the standard written warranty provided.

SCOPE OF WORK / SPECIFICATIONS

The specifications listed herein are not to be considered restrictive to one source of supply. The right is reserved to reject any offering in which the items offered are considered unsatisfactory in any manner. The University will determine if minor deviations from the listed features are acceptable.

The purpose of this Solicitation is to seek supplies. All quoted supplies must be brand new. Shipping costs should be included with bid price. Award will be made by lot.

After award, all deliveries shall be made and all services provided to the location specified by the University of South Carolina in its purchase order. Deliveries shall be FOB Destination, freight prepaid, with all fuel surcharges/hazardous fees included.

Note: Drawings attached are in PDF format for the purpose of this solicitation. Actual CAD drawings will be made available to the successful offeror

Barrel Mandrel Tech Spec: - All Questions: Burton Rhodes (843) 568-2048

The McNAIR Center is seeking the fabrication and delivery of a cylindrical mandrel for Automated Fiber Placement layup. McNAIR needs quotes for three different versions of the same barrel diameter. The specifications are as follows:

3 pieces required:

Tolerances: +/- 0.005

Head Stock Support Bar:

- Length: 72"
- Hole Pattern: 36cm diameter (field verify), 12 bolts (M24)
- Material: Steel – A36

Tail Stock Support Bar:

- Length: 72"
- Hole Pattern: 36cm diameter (field verify), 12 bolts (M24)
- Material: Steel – A36

Mandrel:

- Diameter: 24.000 in
- Length: 40.0 in (option 1)
- Length: 48.0 in (option 2)

- Length: 72.0 in (option 3)
- Maximum deflection: 0.01 mm under 180 psi point load
- Requires 2 lifting points (1/2-13 threading)
- Requires 3 tooling ball locations (IMT 448-12, 0.374" Shank Diameter)
- Material: Steel – A36
- Will be heated in oven/autoclave up to 800°F

Basic Drawing:

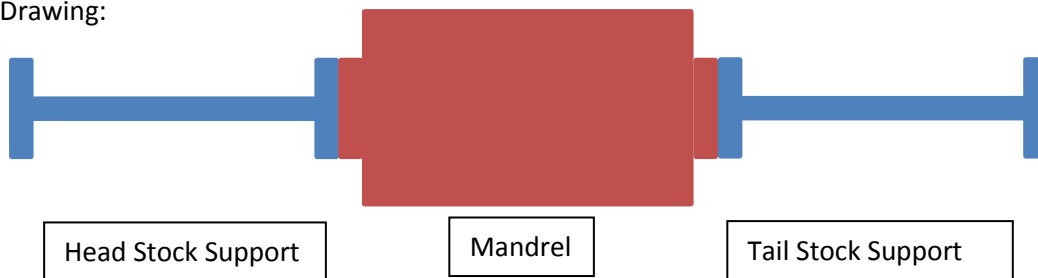

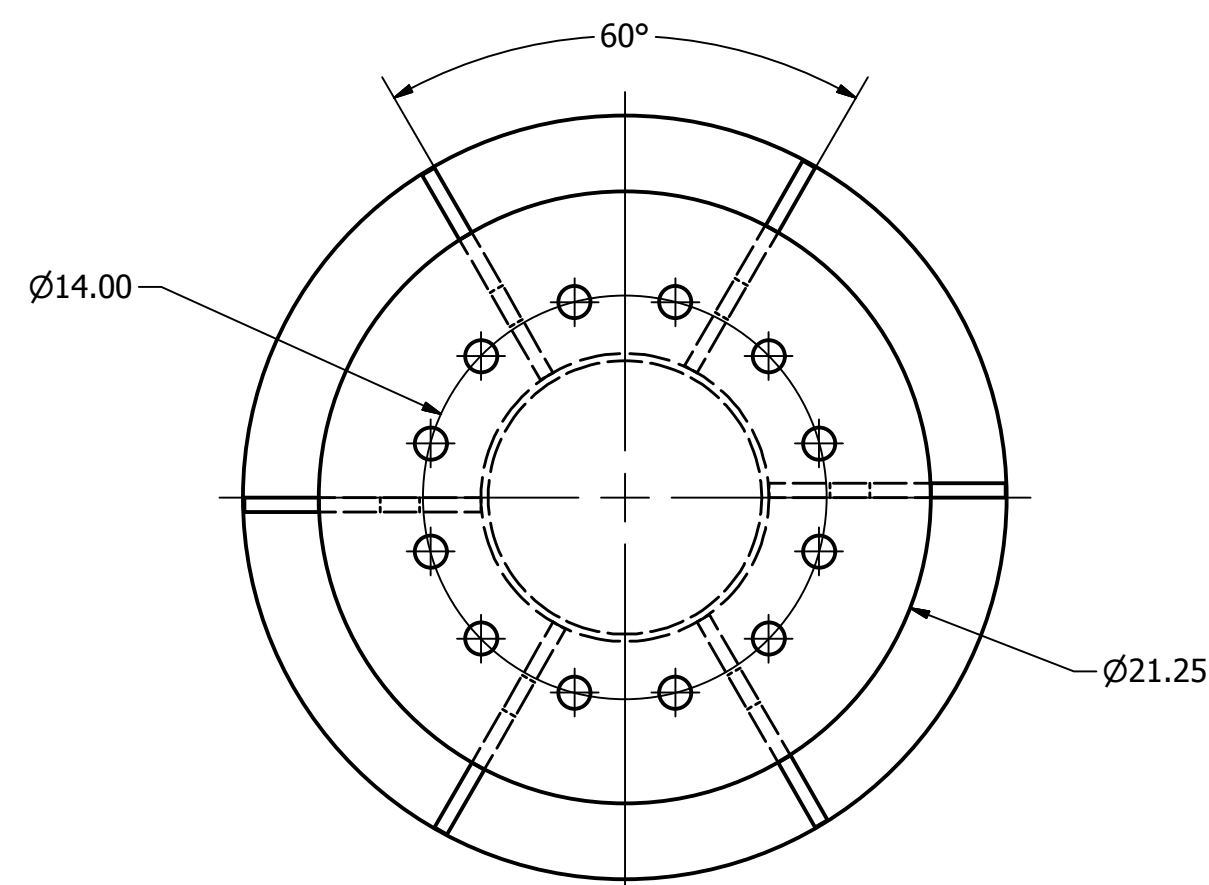
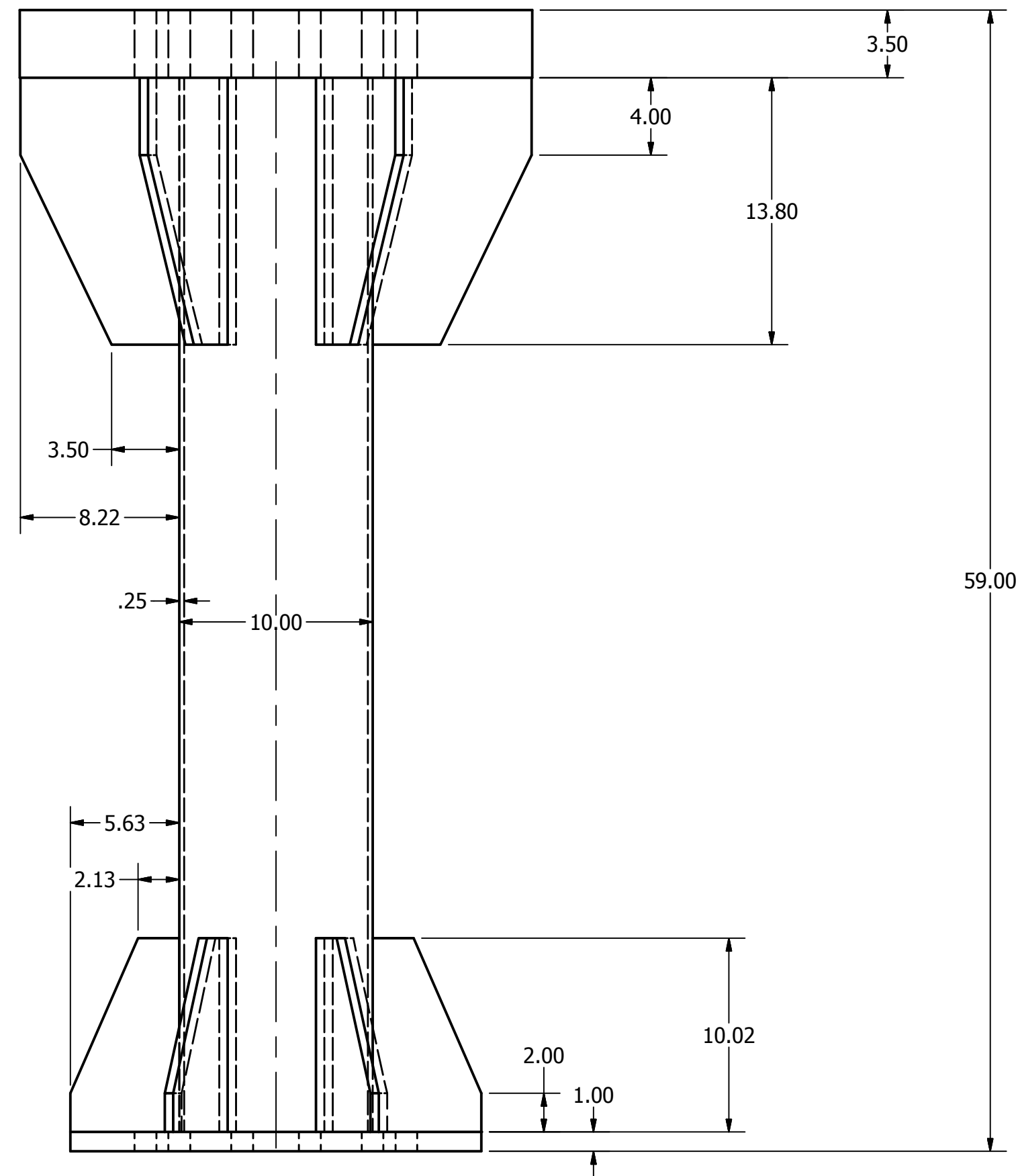
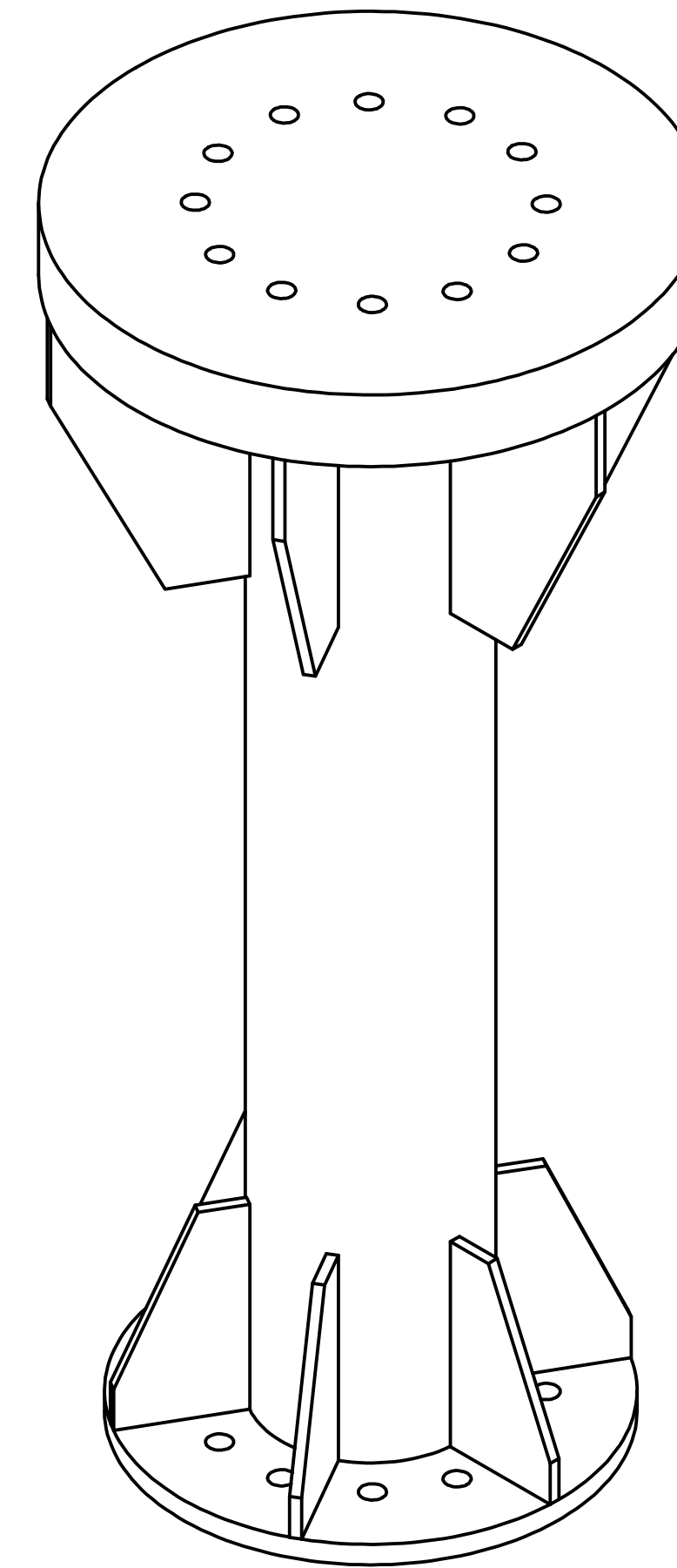
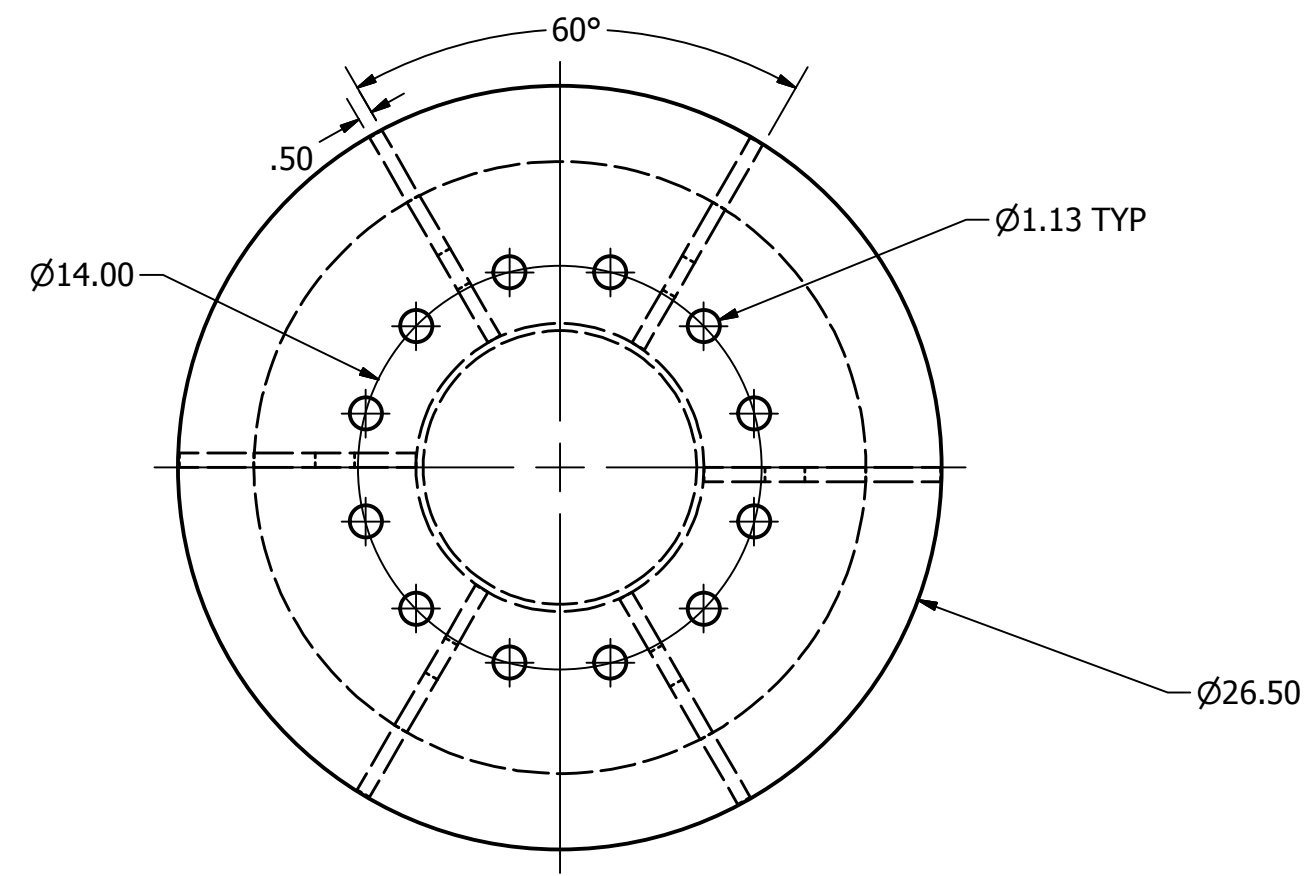

DRAWN	burton	6/14/2016			
CHECKED			TITLE		
QA			Head Stock Support Beam		
MFG					
APPROVED					
			SIZE	DWG NO	REV
			D		
			SCALE	SHEET 1 OF 1	
			0.15 : 1		

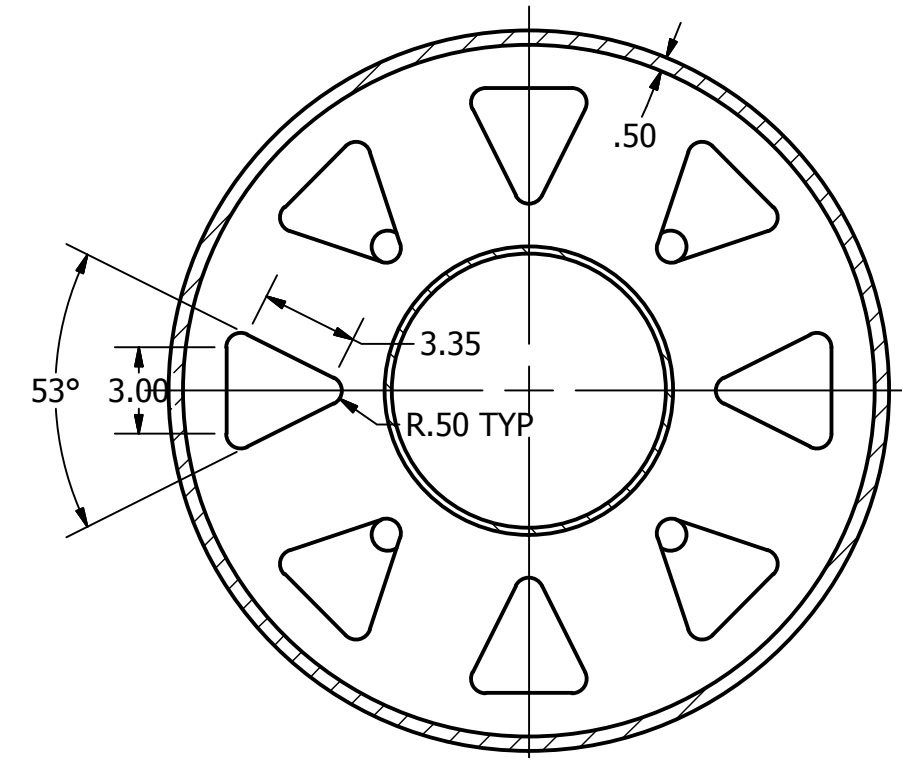
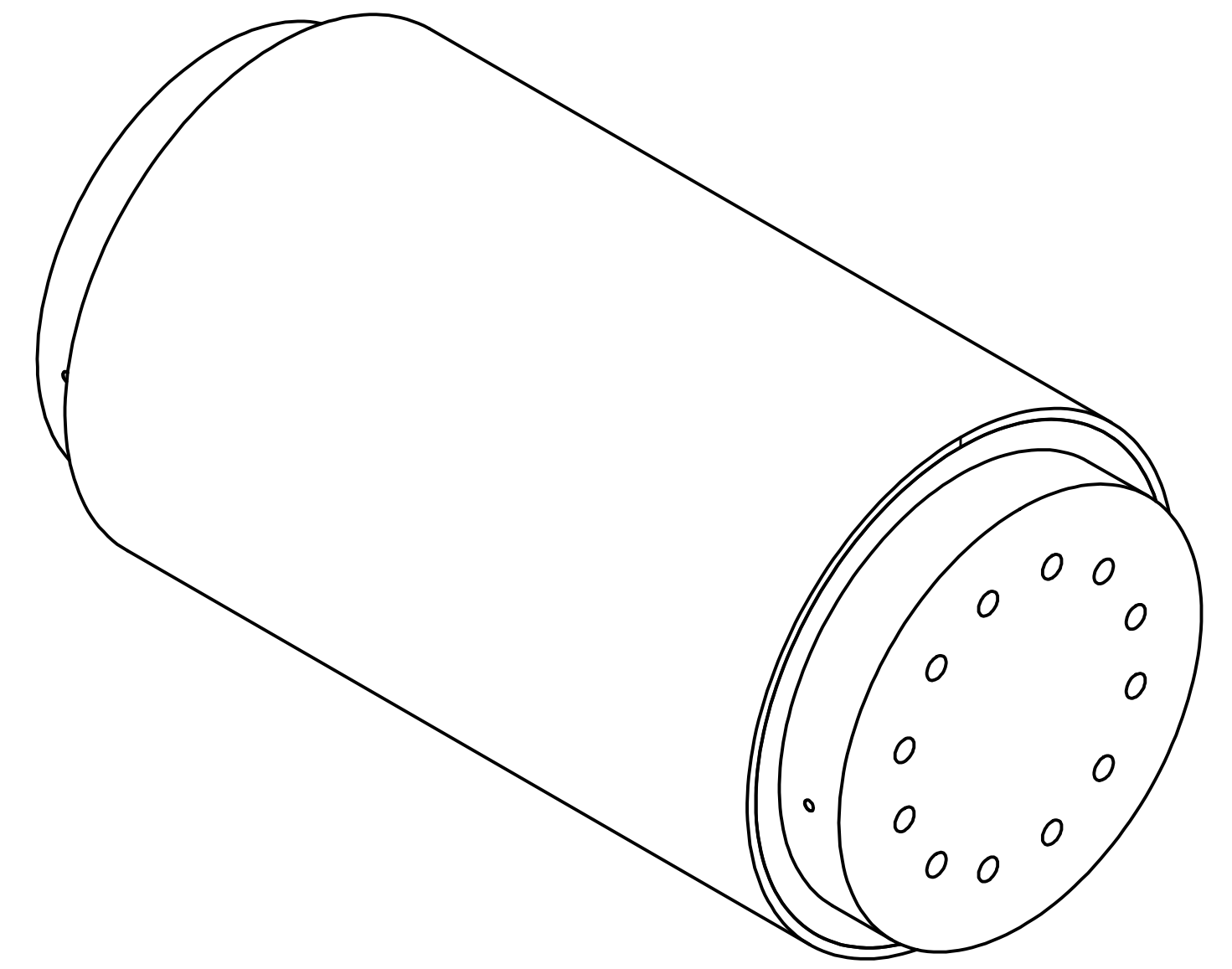
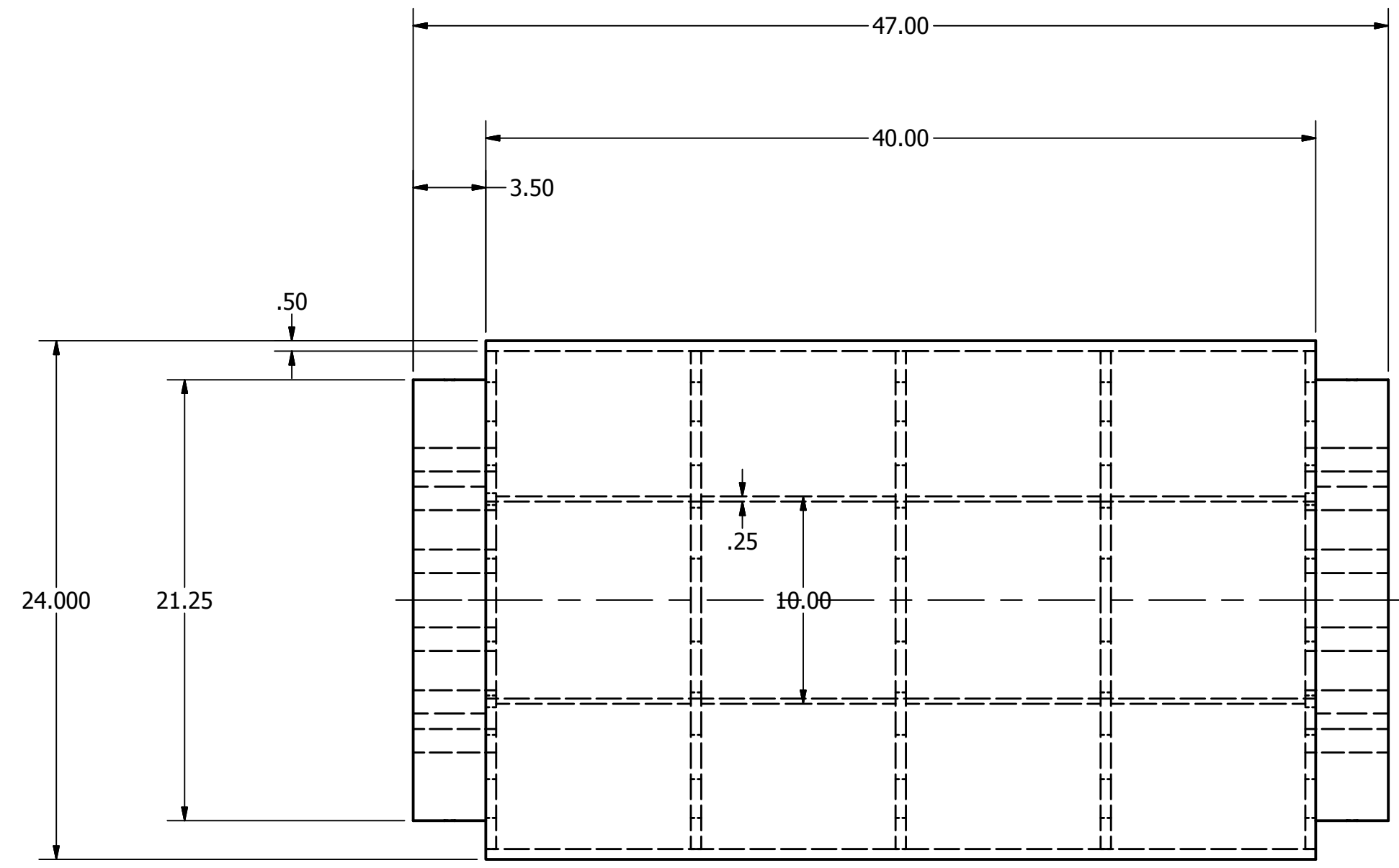

SECTION B-B
SCALE 0.15 : 1

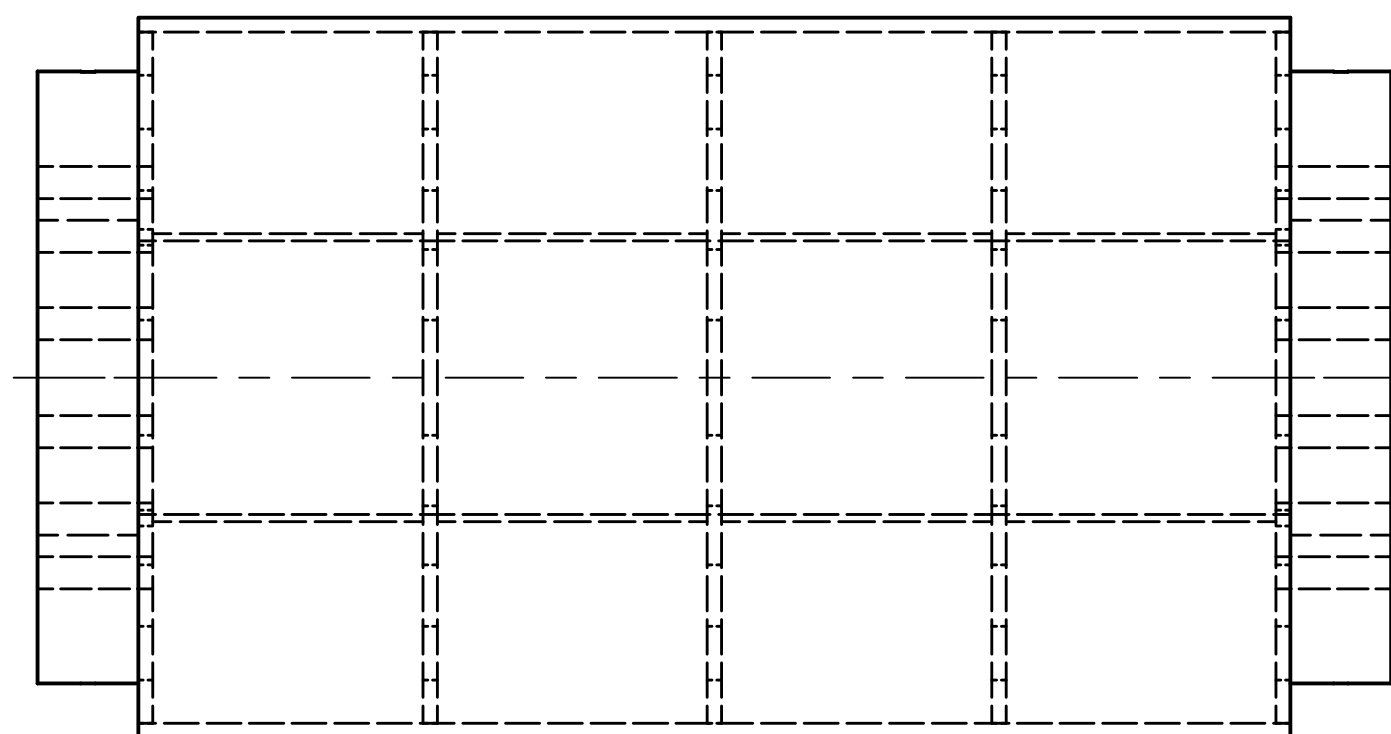
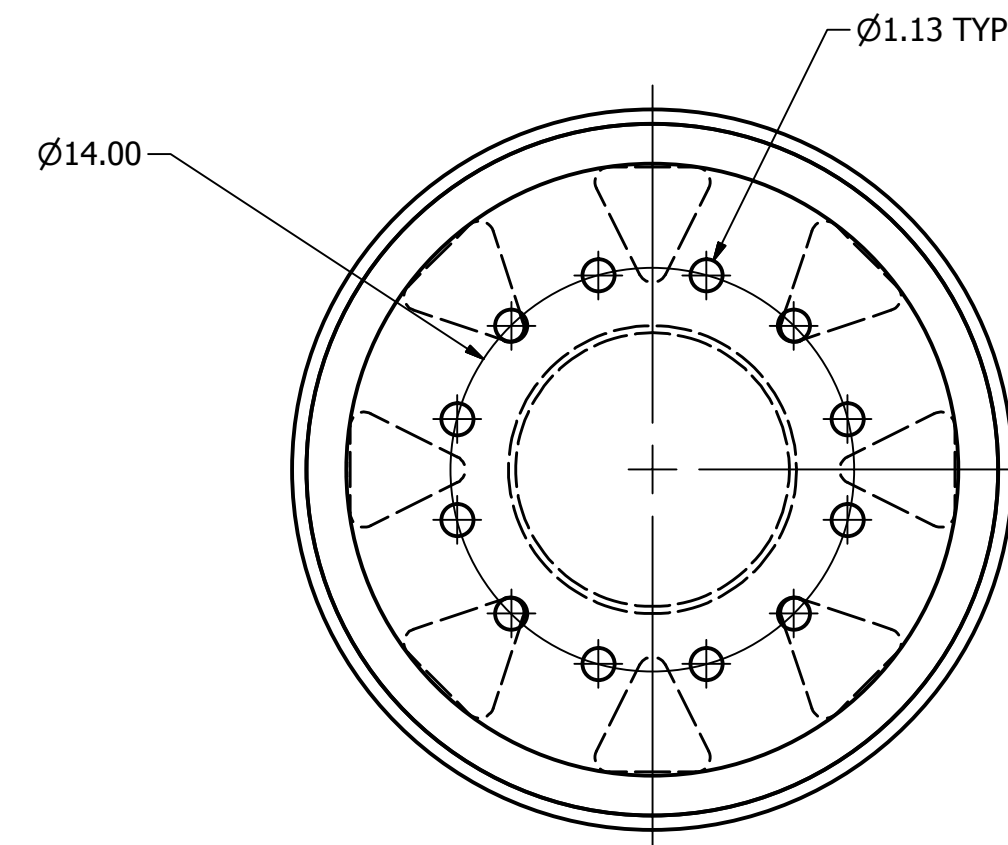
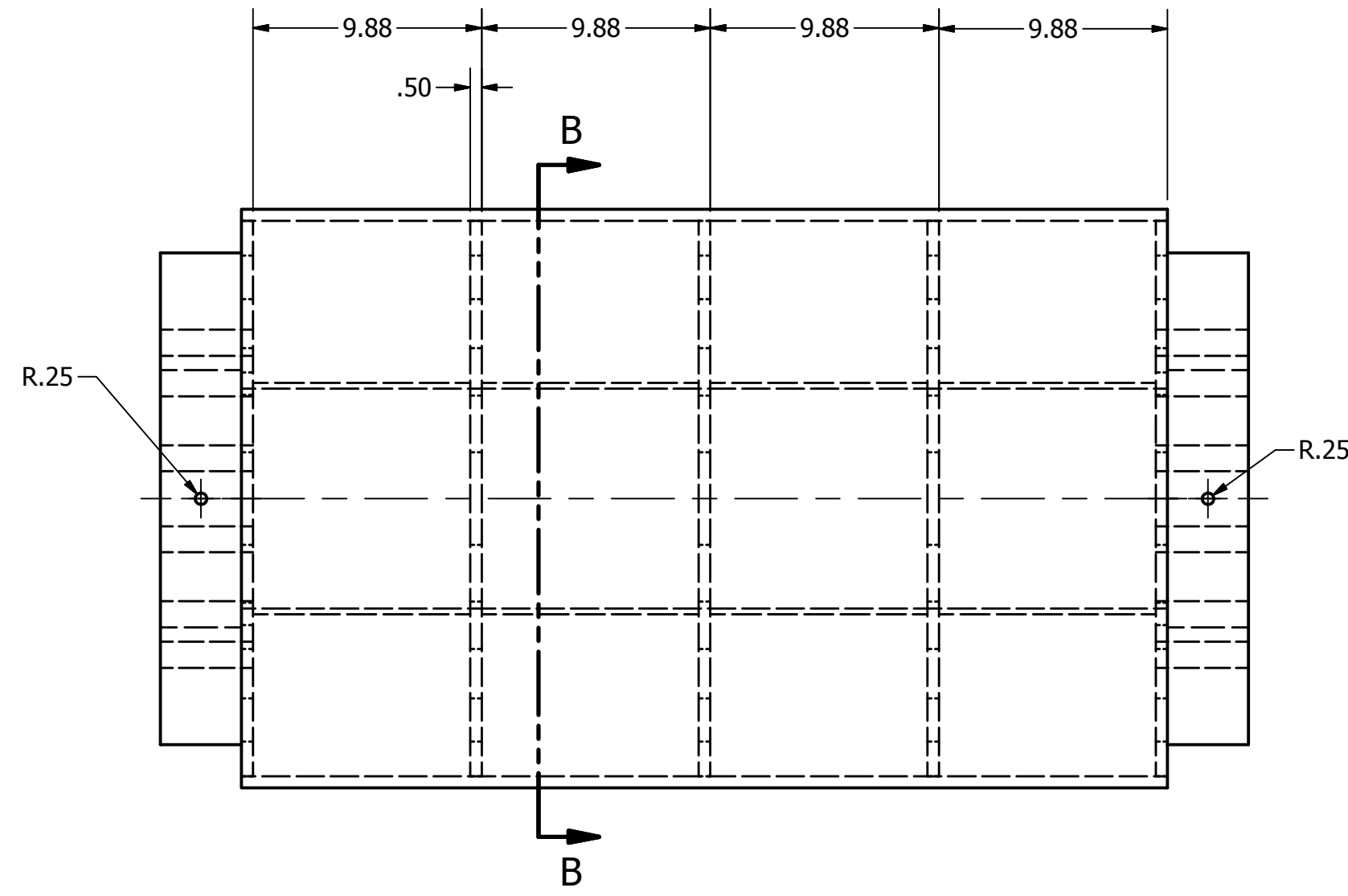

DRAWN	burton	6/14/2016		
CHECKED			TITLE	
QA			24' Diameter Barrel Mandrel	
MFG				
APPROVED				
			SIZE	DWG NO
			D	SolidCylinderMandrelV2
			SCALE	REV
			0.15 : 1	1

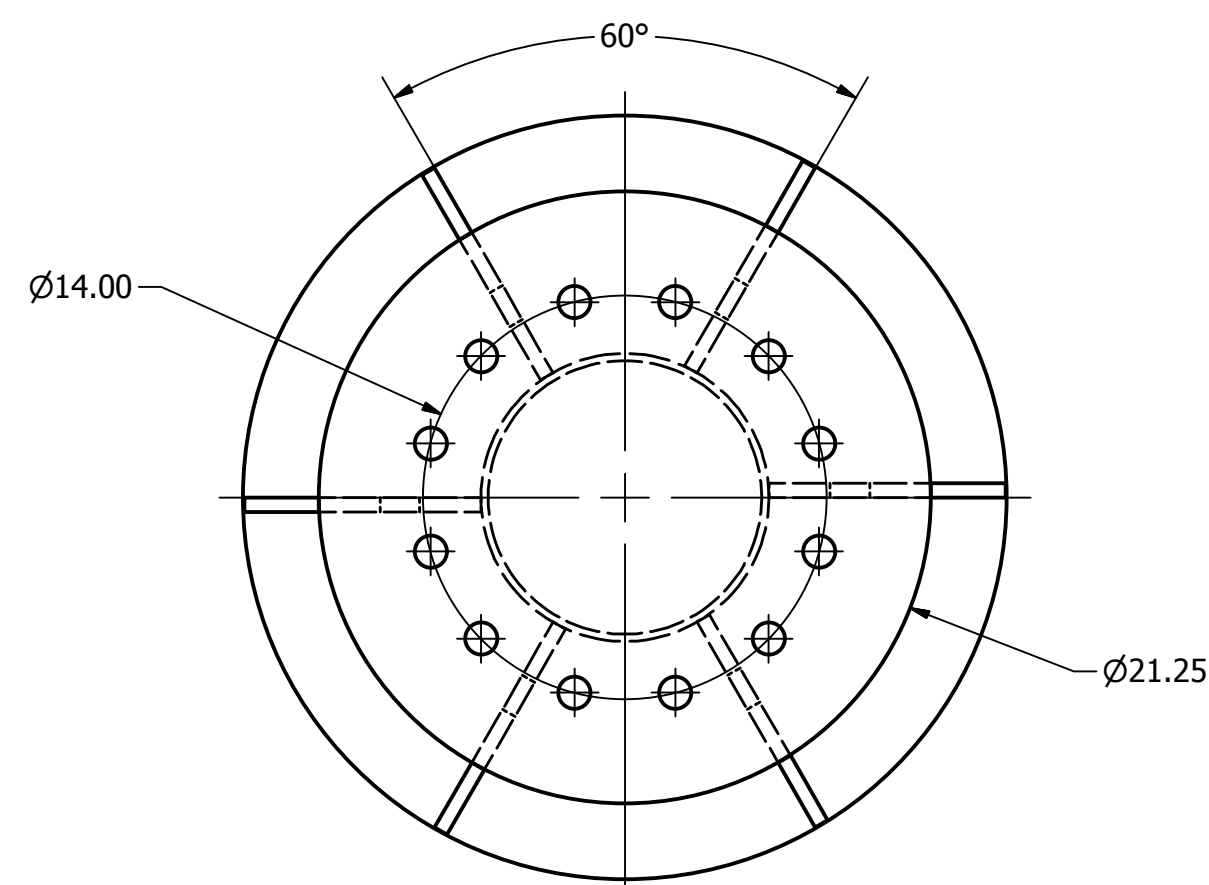
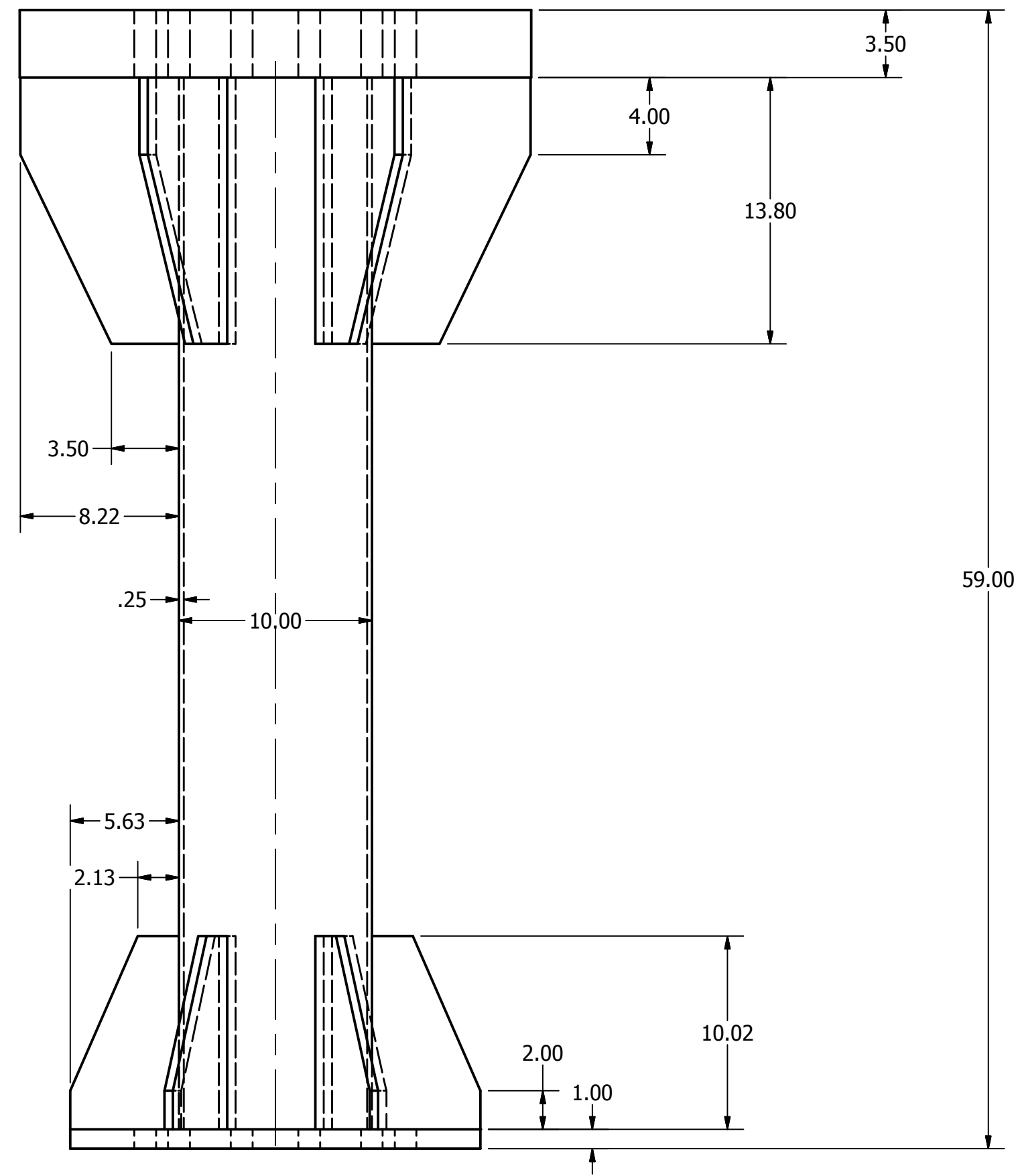
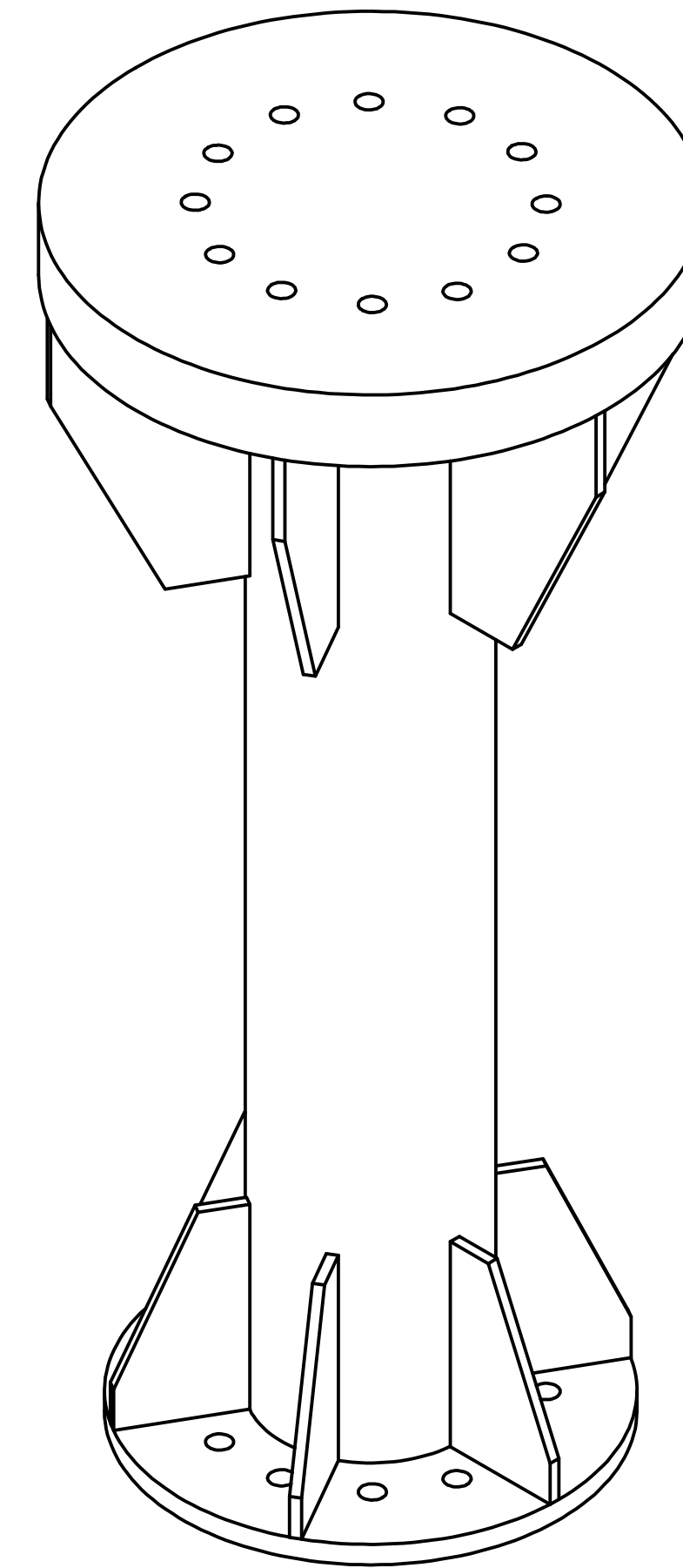
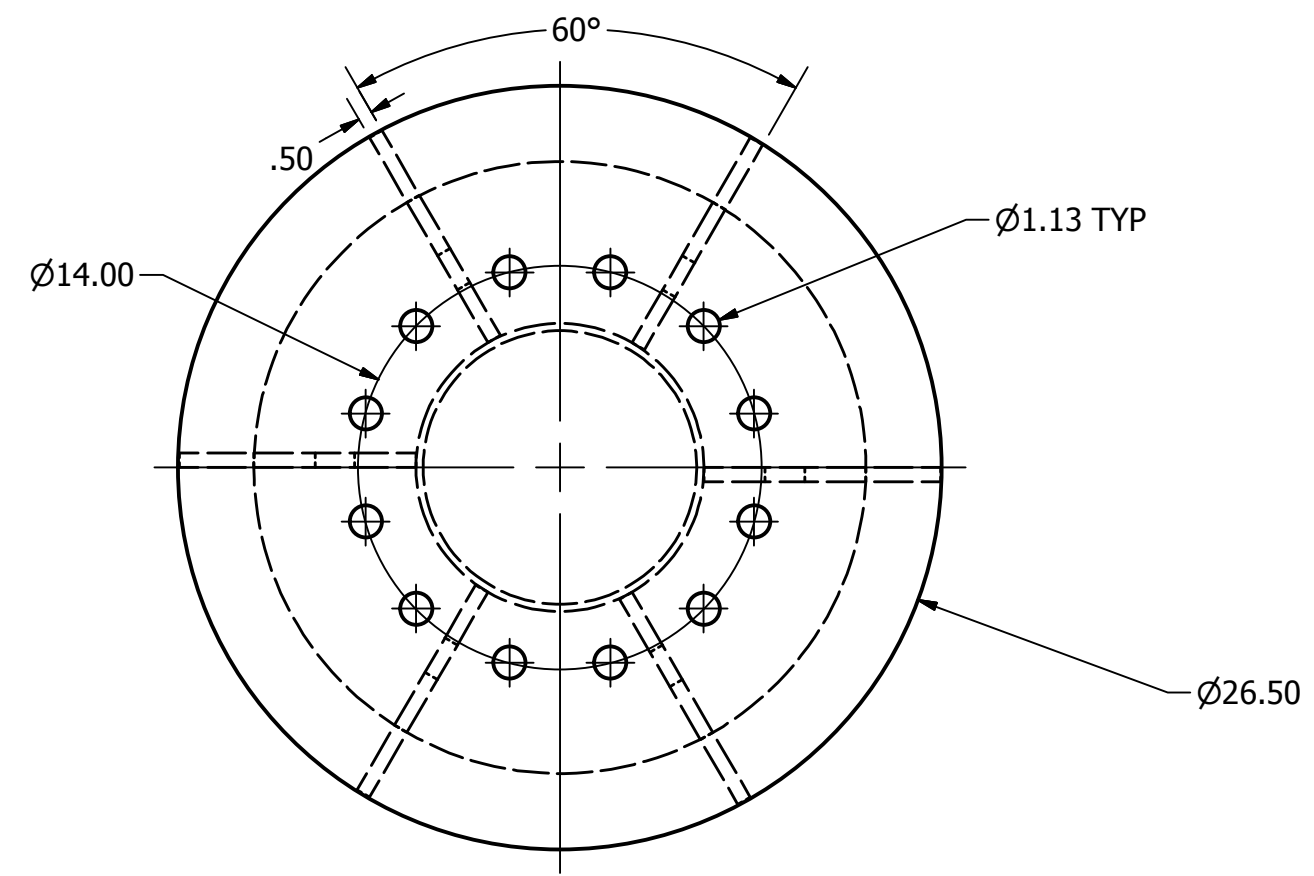

DRAWN	burton	6/14/2016		
CHECKED			TITLE	
QA			Tail Stock Support Beam	
MFG				
APPROVED				
		SIZE	DWG NO	REV
		D	TailStockSupportBeamV2	
		SCALE	SHEET 1 OF 1	
		0.15 : 1		

BIDDING SCHEDULE

Lot: Supplies

Item	Qty	Unit	Description	Unit Price	Extended Price	RVP	USEP	SCEP
1	1	ea	Mandrel as specified	\$	\$			
2	1		Shipping/delivery					
TOTAL PRICE					\$			

Note 1: Do not include taxes with price.

Note 2: All preferences must be claimed by initialing in the space provided in the bid schedule. Preferences are applied by line item whether the award is to be made by line item or lot. If you request a preference, you are certifying that your offer qualifies for the preference you have claimed.

MINORITY PARTICIPATION (JAN 2006)

Is the bidder a South Carolina Certified Minority Business? Yes NO

Is the bidder a Minority Business certified by another governmental entity? Yes NO

If so, please list the certifying governmental entity: _____

Will any of the work under this contract be performed by a SC certified Minority Business as a subcontractor? Yes NO

If so, what percentage of the total value of the contract will be performed by a SC certified Minority Business as a subcontractor? Yes NO

Will any of the work under this contract be performed by a minority business certified by another governmental entity as a subcontractor? Yes NO

If so, what percentage of the total value of the contract will be performed by a minority business certified by another governmental entity as a subcontractor? Yes NO

If a certified Minority Business is participating in this contract, please indicate all categories for which the Business is certified:

- Traditional minority
- Traditional minority, but female
- Women (Caucasian females)
- Hispanic minorities
- DOT referral (Traditional minority)
- DOT referral (Caucasian female)
- Temporary certification
- SBA 8 (a) certification referral
- Other minorities (Native American, Asian, etc.)

(If more than one minority contractor will be utilized in the performance of this contract, please provide the information above for each minority business.)