

JUMPER CARTER SEASE/ARCHITECTS, P.A.
412 MEETING STREET, WEST COLUMBIA, SOUTH CAROLINA 29169
(803) 791-1020 (803) 791-1022 FAX

UNIVERSITY OF SOUTH CAROLINA CAPSTONE CAMPUS ROOM UPGRADES

PROJECT NO: 11103

ADDENDUM 02

March 16, 2012

GENERAL:

1. The Contractor must clearly understand that this project is urgently needed by the client. The start work date will be May 7, 2012. The final completion date including punch list completion will be July 27, 2012. This is an 82 day time period and the Contractor and Subcontractors shall make all necessary provisions to meet this schedule.
2. See attached items from Sims Group Engineers which becomes an integral part of this Addendum.

SPECIFICATIONS:

1. **Table of Contents**; **OMIT** Table of Contents and **REPLACE** with new Table of Contents
2. **SE-330 Bid Form**; **OMIT** SE-330 form and **REPLACE** with new SE-330 Bid Form
3. **Section 012100 Allowances; P 1**: **ADD** 1.8 **Asbestos Abatement (\$12,000)** See the attached specification section 028213 for information
4. **Section 028213 Selective Demolition**: **ADD** new section
5. **Specification Section 084113 Aluminum Framed Entrances and Storefront**; **OMIT** this section in its entirety and **REPLACE** with Specification Sections 084413 Glazed Aluminum Curtain Wall and 0884413A Exterior Canopy
6. **Specification Section 122216 DRAPERY Track and Accessories**: **OMIT** this section in its entirety and **REPLACE** with new Specification Section 122216 attached
7. **Specification Section 122400 Motorized Roller Shades; P2, Part 2**: **ADD**
2.4 CONTROLS – Refer to section 122216 and integrate drapery track control system. Roller shades shall be controllable independently from drapery track.



DRAWINGS:

- 1. Drawing I-7 CEILING DETAILS: OMIT** Drawing I-7 and **REPLACE** it with NEW DRAWING I-7.
- 2. Drawing I-5 DOOR & FINISH SCHEDULES / COLOR SCHEDULE / DOOR & WINDOW TYPES & DETAILS / PANEL DETAILS; CHANGE** Wood Veneer Panel Reveal Details as shown.

Wood Veneer Panels

Provide the following AWI recommended Joints and Transitions in lieu of Details provided on sheet I-5.

(These details methods should be used to prevent the telegraphing of the solid wood edge through the veneer surface as previously detailed).

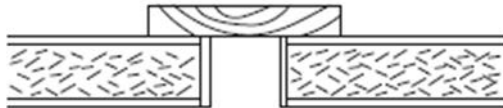

Wood Veneer
Panel Reveals



Solid Wood
Outside
Corner



Solid Wood Reveal
Inside Corner

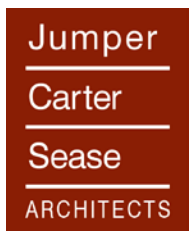

END OF ADDENDUM

<u>DIVISION 0</u>	<u>BIDDING AND CONTRACT DOCUMENTS</u>
SE-310	Request for Advertisement/Invitation for Construction Bids (2011)
AIA-A701-1997	Instructions to Bidders
00201-OSE	Standard Supplemental Instructions to Bidders (2011)
AIA-A310-2010	Bid Bond (2010 Edition)
SE-330	Standard Bid Form (2011)
AIA-101-2007	Standard Form of Agreement Between Owner & Contractor
00501-OSE	Standard Modifications to AIA A101-2011
AIA-A201-2007	General Conditions of the Contract for Construction
00811-OSE	Standard Supplementary Conditions (2011)
SE-355	Performance Bond (2011)
SE-357	Labor & Material Payment Bond (2011)
SE-480	Construction Change Order (2011)
-----	Contractor's One Year Guarantee
-----	Campus Vehicle Expectations
-----	USC Supplemental General Conditions for Construction Projects

<u>DIVISION 1</u>	<u>GENERAL REQUIREMENTS</u>
011000	Summary
011010-A	Special Conditions
012000	Schedule of Completion & Liquidated Damages
121000	Allowances
012300	Alternates
012400	Contract Modification Procedures
012500	Substitution Procedures
012500-A	Substitution Request Form
012900	Payment Procedures
013100	Project Management and Coordination
013200	Construction Progress Documentation
013330	Submittal Procedures
014000	Quality Requirements
014001	Chapter 1 Inspections and Chapter 17 Special Inspections
014200	References
015000	Temporary Facilities and Controls
015240	Construction Waste Management
017300	Execution
017310	Cutting and Patching
017320	Selective Demolition
017400	Asbestos Free Warranty
017500	Lead Free Warranty
017700	Closeout Procedures
017839	Project Record Documents
018000	List of Drawings

<u>DIVISION 2</u>	<u>EXISTING CONDITIONS</u>
028213	Selective Demolition

DIVISION 3 **CONCRETE** – NOT USED

<u>DIVISION 4</u>	<u>MASONRY</u>
044000	Natural Thin Veneer Stone

<u>DIVISION 5</u>	<u>METALS</u>
055213	Pipe and Tube Railings

<u>DIVISION 6</u>	<u>WOOD, PLASTIC & COMPOSITES</u>
064023	Interior Architectural Woodwork

DIVISION 7 **THERMAL AND MOISTURE PROTECTION**
079000 Caulking and Sealants

DIVISION 8 **OPENINGS**
081416 Flush Wood Doors
~~084113 Aluminum Framed Entrances & Storefronts~~
084413 Glazed Aluminum Curtain Wall
084413A Exterior Canopy
087100 Finish Hardware
088100 Glass and Glazing

DIVISION 9 **FINISHES**
092900 Gypsum Wallboard Systems
095123 Acoustical Tile Ceilings
096513 Resilient Base and Accessories
096600 Resilient Tile Flooring
096813 Tile Carpeting
099123 Interior Painting

DIVISION 10 **SPECIALTIES**
102200 Operable Panel Partition
108500 Miscellaneous Specialties

DIVISION 12 **FURNISHINGS**
122200 Window Drapery
122216 Drapery Track and Accessories
122400 Motorized Roller Shades

DIVISION 21 **FIRE SUPPRESSION** – NOT USED

DIVISION 23 **HEATING, VENTILATION AND IR CONDITIONING (HVAC)**
230000 Mechanical, General
230593 Mechanical, Testing and Balancing
230700 Mechanical, Insulation
232113 Mechanical, Piping
233123 Mechanical, Ductwork
233423 Mechanical, Air Distribution
238143 Mechanical, Ductless Split System Heat Pump

DIVISION 25 **INTEGRATED AUTOMATION**
255500 Automatic Temperature Controls

DIVISION 26 **ELECTRICAL**
260500 Electrical Basic Materials and Methods
260529 Hangers and Supports for Electrical Systems
264313 Surge Protection Device (SPD)

END OF SECTION 000010

**SE-330 – LUMP SUM BID
BID FORM**

Bidders shall submit bids on only Bid Form SE-330.

BID SUBMITTED BY: _____
(Bidder's Name)

BID SUBMITTED TO: University of South Carolina
(Owner's Name)

FOR PROJECT: PROJECT NAME USC - Capstone Campus Room Upgrades
PROJECT NUMBER H27-1987

OFFER

§ 1. In response to the Invitation for Construction Bids and in compliance with the Instructions to Bidders for the above-named Project, the undersigned Bidder proposes and agrees, if this Bid is accepted, to enter into a Contract with the Owner on the terms included in the Bidding Documents, and to perform all Work as specified or indicated in the Bidding Documents, for the prices and within the time frames indicated in this Bid and in accordance with the other terms and conditions of the Bidding Documents.

§ 2. Pursuant to Section 11-32-3030(1) of the SC Code of Laws, as amended, Bidder has submitted Bid Security as follows in the amount and form required by the Bidding Documents:

- Bid Bond with Power of Attorney Electronic Bid Bond Cashier's Check

(Bidder check one)

§ 3. Bidder acknowledges the receipt of the following Addenda to the Bidding Documents and has incorporated the effects of said Addenda into this Bid:

ADDENDUM No: _____

§ 4. Bidder accepts all terms and conditions of the Invitation for Bids, including, without limitation, those dealing with the disposition of Bid Security. Bidder agrees that this Bid, including all Bid Alternates, if any, may not be revoked or withdrawn after the opening of bids, and shall remain open for acceptance for a period of 60 Days following the Bid Date, or for such longer period of time that Bidder may agree to in writing upon request of the Owner.

§ 5. Bidder herewith offers to provide all labor, materials, equipment, tools of trades and labor, accessories, appliances, warranties and guarantees, and to pay all royalties, fees, permits, licenses and applicable taxes necessary to complete the following items of construction work:

§ 6.1 BASE BID WORK *(as indicated in the Bidding Documents and generally described as follows):* Project includes complete renovations to the Capstone Campus Room. Small and minority business participation is encouraged..

_____, which sum is hereafter called the Base Bid.

(Bidder - insert Base Bid Amount on line above)

**SE-330 – LUMP SUM BID
BID FORM**

§ 6.2 BID ALTERNATES - as indicated in the Bidding Documents and generally described as follows:

ALTERNATE # 1 (Brief Description): _____

ADD TO or **DEDUCT FROM BASE BID:** _____

(Bidder to Mark appropriate box to clearly indicate the price adjustment offered for each alternate)

ALTERNATE # 2 (Brief Description): _____

ADD TO or **DEDUCT FROM BASE BID:** _____

(Bidder to Mark appropriate box to clearly indicate the price adjustment offered for each alternate)

ALTERNATE # 3 (Brief Description): _____

ADD TO or **DEDUCT FROM BASE BID:** _____

(Bidder to Mark appropriate box to clearly indicate the price adjustment offered for each alternate)

SE-330 – LUMP SUM BID

BID FORM

§ 7. LISTING OF PROPOSED SUBCONTRACTORS PURSUANT TO SECTION 3020(b)(i), CHAPTER 35, TITLE 11 OF THE SOUTH CAROLINA CODE OF LAWS, AS AMENDED – (See Instructions on the following page BF-2A)

Bidder shall use the below-listed Subcontractors in the performance of the Subcontractor Specialty work listed:

SUBCONTRACTOR SPECIALTY By License Classification and/or Subclassification (Completed by Owner)	SUBCONTRACTOR'S PRIME CONTRACTOR'S NAME (Must be completed by Bidder) BASE BID	SUBCONTRACTOR'S PRIME CONTRACTOR'S SC LICENSE NUMBER
Electrical		
HVAC		
ALTERNATE 1		
ALTERNATE 2		
ALTERNATE 3		

If a Bid Alternate is accepted, Subcontractors listed for the Bid Alternate shall be used for the work of both the Alternate and the Base Bid work.

**SE-330 – LUMP SUM BID
BID FORM****INSTRUCTIONS FOR
SUBCONTRACTOR LISTING**

1. Section 7 of the Bid Form sets forth a list of subcontractor specialties for which bidder is required to identify by name the subcontractor(s) Bidder will use to perform the work of each listed specialty. Bidder must identify only the subcontractor(s) who will perform the work and no others.
2. For purposes of subcontractor listing, a Subcontractor is an entity who will perform work or render service to the prime contractor to or about the construction site. Material suppliers, manufacturers, and fabricators that will not perform physical work at the site of the project but will only supply materials or equipment to the bidder or proposed subcontractor(s) are not subcontractors and Bidder should not insert their names in the spaces provided on the bid form. Likewise, Bidder should not insert the names of sub-subcontractors in the spaces provided on the bid form but only the names of those entities with which bidder will contract directly.
3. Bidder must only insert the names of subcontractors who are qualified to perform the work of the listed specialties as specified in the Bidding Documents and South Carolina Licensing Laws.
4. If under the terms of the Bidding Documents, Bidder is qualified to perform the work of a specialty listed and Bidder does not intend to subcontract such work but to use Bidder's own employees to perform such work, the Bidder must insert its own name in the space provided for that specialty.
5. If Bidder intends to use multiple subcontractors to perform the work of a single specialty listing, Bidder must insert the name of each subcontractor Bidder will use, preferably separating the name of each by the word **“and”**. If Bidder intends to use both his own employees to perform a part of the work of a single specialty listing and to use one or more subcontractors to perform the remaining work for that specialty listing, bidder must insert his own name and the name of each subcontractor, preferably separating the name of each with the word **“and”**.
6. Bidder may not list subcontractors in the alternative nor in a form that may be reasonably construed at the time of bid opening as a listing in the alternative. A listing that requires subsequent explanation to determine whether or not it is a listing in the alternative is non-responsive. If bidder intends to use multiple entities to perform the work for a single specialty listing, bidder must clearly set forth on the bid form such intent. Bidder may accomplish this by simply inserting the word **“and”** between the name of each entity listed for that specialty. Owner will reject as non-responsive a listing that contains the names of multiple subcontractors separated by a blank space, the word **“or”**, a virgule (that is a /), or any separator that the Owner may reasonably interpret as a listing in the alternative.
7. If Bidder is awarded the contract, bidder must, except with the approval of the owner for good cause shown, use the listed entities to perform the work for which they are listed.
8. If bidder is awarded the contract, bidder will not be allowed to substitute another entity as subcontractor in place of a subcontractor listed in Section 7 of the Bid except for one or more of the reasons allowed by the SC Code of Laws.
9. Bidder's failure to insert a name for each listed specialty subcontractor will render the Bid non-responsive.

**SE-330 – LUMP SUM BID
BID FORM**

§ 8. LIST OF MANUFACTURERS, MATERIAL SUPPLIERS, AND SUBCONTRACTORS OTHER THAN SUBCONTRACTORS LISTED IN SECTION 7 ABOVE (FOR INFORMATION ONLY): Pursuant to instructions in the Invitation for Bids, if any, Bidder will provide to Owner upon the Owner’s request and within 24 hours of such request, a listing of manufacturers, material suppliers, and subcontractors, other than those listed in Section 7 above, that Bidder intends to use on the project. Bidder acknowledges and agrees that this list is provided for purposes of determining responsibility and not pursuant to the subcontractor listing requirements of SC Code Ann § 11-35-3020(b)(i).

§ 9. TIME OF CONTRACT PERFORMANCE AND LIQUIDATED DAMAGES

a. **CONTRACT TIME:** Bidder agrees that the Date of Commencement of the Work shall be established in a Notice to Proceed to be issued by the Owner. Bidder agrees to substantially complete the Work within 82 calendar days from the Date of Commencement, subject to adjustments as provided in the Contract Documents.

b. **LIQUIDATED DAMAGES:** Bidder further agrees that from the compensation to be paid, the Owner shall retain as Liquidated Damages the sum of \$250.00 for each calendar day the actual construction time required to achieve Substantial Completion exceeds the specified or adjusted time for Substantial Completion as provided in the Contract Documents. This sum is intended by the parties as the predetermined measure of compensation for actual damages, not as a penalty for nonperformance.

§ 10. AGREEMENTS

- a. Bidder agrees that this bid is subject to the requirements of the law of the State of South Carolina.
- b. Bidder agrees that at any time prior to the issuance of the Notice to Proceed for this Project, this Project may be canceled for the convenience of, and without cost to, the State.
- c. Bidder agrees that neither the State of South Carolina nor any of its agencies, employees or agents shall be responsible for any bid preparation costs, or any costs or charges of any type, should all bids be rejected or the Project canceled for any reason prior to the issuance of the Notice to Proceed.

§ 11. ELECTRONIC BID BOND

By signing below, the Principal is affirming that the identified electronic bid bond has been executed and that the Principal and Surety are firmly bound unto the State of South Carolina under the terms and conditions of the AIA Document A310, Bid Bond, included in the Bidding Documents.

Electronic Bid Bond Number: _____

Signature and Title: _____

**SE-330 – LUMP SUM BID
BID FORM**

BIDDER'S TAXPAYER IDENTIFICATION

FEDERAL EMPLOYER'S IDENTIFICATION NUMBER: _____

OR

SOCIAL SECURITY NUMBER: _____

CONTRACTOR'S CLASSIFICATIONS AND SUBCLASSIFICATIONS WITH LIMITATIONS

Classification(s) & Limits: _____

Subclassification(s) & Limits: _____

SC Contractor's License Number(s): _____

BY SIGNING THIS BID, THE PERSON SIGNING REAFFIRMS ALL REPRESENTATIONS AND CERTIFICATIONS MADE BY BOTH THE PERSON SIGNING AND THE BIDDER, INCLUDING WITHOUT LIMITATION, THOSE APPEARING IN ARTICLE 2 OF THE INSTRUCTIONS TO BIDDER. THE INVITATION FOR BIDS, AS DEFINED IN THE INSTRUCTIONS TO BIDDERS, IS EXPRESSLY INCORPORATE BY REFERENCE.

SIGNATURE

BIDDER'S LEGAL NAME: _____

ADDRESS: _____

BY: _____
(Signature)

DATE: _____

TITLE: _____

TELEPHONE: _____

EMAIL: _____

- 1.0 GENERAL
- 1.1 RELATED DOCUMENTS:
A. Drawings and general provisions of Contract including General & Supplementary Conditions and other Division-1 specification sections, apply to work of this section.
- 1.2 SCOPE: This section describes the allowances that are to be included in the contractor's bid and entered on the Form of Proposal
- 1.3 ALLOWANCE: The following allowances to be used as directed by Architect. Any unused portion of these allowances shall be credited to the Owner at the completion of the work. These allowances shall be considered actual costs and the contractor's profit, insurance, taxes, installation cost, and protection of installed products, will be figured in the bids, except as otherwise noted.
- 1.4 SIGNAGE ALLOWANCE:
\$5,000.00 including SC Sales Tax and Installation
- ~~1.5 DOOR HARDWARE ALLOWANCE: DELETED PER ADDENDUM #1
\$5,000.00 including SC Sales Tax and Installation~~
- 1.6 CARPET ALLOWANCE:
\$60.00/Square yard including SC Sales Tax and Installation
(Carpet quantity identified on plans)
- ~~1.7 DRAPERY ALLOWANCE: DELETED PER ADDENDUM #1
\$9,000.00 including SC Sales Tax and Installation~~
- 1.8 ASBESTOS ABATEMENT:
\$12,000.00 including SC Sales Tax. See specification section 028213 for information.

END OF SECTION

1.0 GENERAL

- 1.1 SCOPE: This section describes the allowances that are to be included in the contractor's bid and entered on the Form of Proposal

Refer to the attached document FM00390670 (HazMat Survey) for existing construction products identified as containing various HazMat Materials or existing construction products with the potential to contain HazMat materials.

- 1.2 ALLOWANCE: Allow \$12,000 for the removal of asbestos containing materials or other similar HazMat materials noted in the attached survey. This \$12,000 includes materials, labor and SC Sales Tax.

2.0 PRODUCTS: NOT USED

3.0 EXECUTION:

- 3.1 SUSPECT MATERIALS: Should suspect materials be encountered, DO NOT DISTURB, and contact the owner immediately.

END OF SECTION

FM00390670

USC Work Order

Description HAZMAT SURVEY

Site	COLUMBIA	Assigned To	JPROVENCE
Building	039 CAPSTONE	Crew	HAZMAT
Floor	Room:	Start Date	Priority 1
Equipment		Due date	12-MAR-12
		Request Date	09-MAR-12
			by PFISHER

Request #	FM00390670	Description	HAZMAT SURVEY
Parent WO #			

CP Number	CP00246261	CAPSTONE CAMPUS ROOM UPGRADES
-----------	------------	-------------------------------

State/Internal Project Number	H27-1987
-------------------------------	----------

Requestor	Project Manager	FISHER, PETER L.
Telephone	Telephone	777-9346
Alternate	Estimated Cost	\$ 224.00
Telephone	Billing	FIXED PRICE
Non-Available Time	53100-W509-57120 (CAPSTONE CAMPUS ROOM UPGRADES)	

Task List
 SURVEY FOR CAMPUS ROOM INTERIOR RENOVATION - ROOM TO BE COMPLETELY RENOVATED FOR NEW INTERIOR FINISHES - IDENTIFY ACM AND REMEDIATION OPTIONS CONTACT PM WITH QUESTIONS

DATE WORK STARTED	CAUSE	
DATE WORK COMPLETED	CONDITION	
EQUIPMENT		
CLOSING REMARKS		
BENCHSTOCK MATERIALS		
Qty	Description	Price Per Unit

Supervisor's Approval _____

Note Date	Title
15-MAR-12	HAZMAT SURVEY RESULTS
SURVEY DATE:3-13-2012	
INSPECTOR #: DARRYL WASHINGTON II BI-00568	
STATUS: THE FOLLOWING MATERIALS HAVE BEEN TESTED FOR ASBESTOS AND LEAD MATERIALS RESULTS FOLLOWS	
SHEET ROCK - NEGATIVE FOR ASBESTOS CONTAINING MATERIALS	
JOINT COMPOUND- POSITIVE FOR ASBESTOS CONTAINING MATERIALS	
BASEMOLDING IN CAMPUS ROOM - NEGATIVE FOR ASBESTOS CONTAINING MATERIALS	
BASEMOLDING MASTIC IN CAMPUS ROOM - NEGATIVE FOR ASBESTOS CONTAINING MATERIALS	
BASEMOLDING IN CLOSET- NEGATIVE FOR ASBESTOS CONTAINING MATERIALS	
BASEMOLDING MASTIC IN CLOSET- NEGATIVE FOR ASBESTOS CONTAINING MATERIALS	
12X12 FLOOR TILE IN CLOSET - POSITIVE FOR ASBESTOS CONTAINING MATEIRALS	

BLACK FLOORING MASTIC IN CLOSET- POSITIVE FOR ASBESTOS CONTAINING MATERIALS

2X2 WHITE CEILING TILE (4 SQUARES PER TILE)- NEGATIVE FOR ASBESTOS CONTAINING MATERIALS

WHITE PAINT ON SHEET ROCK - NEGATIVE FOR LEAD BASE PAINT

WHITE PAINT ON CONCRETE WALL MATERIAL @ WINDOWS- NEGATIVE FOR LEAD BASE PAINT

GREEN PAINT ON CONCRETE (STORAGE ROOM)- NEGATIVE FOR LEAD BASE PAINT

GREEN PAINT ON SHEETROCK (STORAGE ROOM)- NEGATIVE FOR LEAD BASE PAINT

BLACK PAINT (WINDOW FRAMING IN PLACE)- NEGATIVE FOR LEAD BASE PAINT

NO SUSPECT MATERIAL UNDER CARPET IN THE CAMPUS ROOM. INSPECTORS LOOKED ABOVE THE CEILING AND IT APPEARS TO BE A LOW CUT CEILING WITH METAL DECKING NO SUSPECT MATERIAL IN PLACE. THE WALL WITH SHEET ROCK IN PLACE IS CONNECTED TO A GREEN CONCRETE BLOCK WALL MATERIAL IN THE KITCHEN THAT WAS TESTED PREVIOUSLY TESTED FOR LEAD AND IS POSITIVE FOR LEAD BASE PAINT.THERE MAY OR MAY NOT BE ANY SHEET ROCK BEHIND THE WOODEN WALLS IN PLACE. DUE TO THE ASBESTOS JOINT COMPOUND IN PLACE PLEASE CONSIDER WHAT KIND OF MATERIAL THAT YOU MAY COME INTO CONTACT WITH. INSPECTORS TOOK THE APPROPRIATE AMOUNT OF SAMPLES FOR THE WALL TAKEN OUT, AND IF WOODEN WALLS IN PLACE HAVE TO BE REMOVED THERE IS A CAMPUS WIDE SURVEY IN PLACE FOR CAPSTONE THAT HAS MORE SAMPLES THAT REFLECT THAT THE JOINT COMPOUND IN PLACE IS POSITIVE FOR ASBESTOS CONTAINING MATERIALS.

MATERIALS YOU MAY COME INTO CONTACT WITH NOT LISTED THAT MAY BE BEHIND A WALL CAVITY OR IN THE HVAC BULK HEAD IN PLACE

1. HVAC BLACK MASTIC - POSITIVE FOR ACM
2. GREEN / OLIVE HVAC DUCT MASTIC- POSITIVE FOR ACM
3. TSI - POSITIVE FOR ACM
4. FOAMGLASS WITH BLACK MASTIC - POSITIVE FOR ACM
5. CAULK - (AROUND WINDOWS OR JAMS)- POSITIVE FOR NEGATIVE FOR ACM
6. FIREPROOFING (THIS MATERIAL IS LOCATED IN THE KITCHEN RIGHT NEXT TO THE CAMPUS ROOM, AND OFFICE AND SITTING AREA OF THE BUILDING.)- POSITIVE FOR ASBESTOS CONTAINING MATERIALS

MATERIALS NOT SUSPECT FOR ACM IN PLACE

1. GLASS
2. WOOD
3. METAL
4. CARPET
5. ANY ELECTRICAL COMPONENTS UNLESS OLDER THAN 1985

IF YOU ENCOUNTER ANY SUSPECT MATERIALS IN PLACE AND NOT LISTED ABOVE AND DEEM IT SUSPECT FOR ASBESTOS OR LEAD PLEASE STOP WORK AND CALL THE ASBESTOS PROGRAM MANAGER FOR FURTHER TESTING OR ASBESTOS OR LEAD ABATEMENT. REFER TO THE SURVEY RESULTS DOCUMENT ATTACHED TO THE WO FOR DETAILED INFORMATION.

13-FEB-09 ASBESTOS MAY BE PRESENT IN THIS BUILDING

WARNING - ASBESTOS EXPOSURE ALERT - EXPOSURE TO ASBESTOS MAY BE HARMFUL TO YOUR HEALTH

AS OF 02/04/2004 THE FOLLOWING AREAS WITHIN THE BUILDING HAVE BEEN IDENTIFIED BY SURVEY TO CONTAIN ASBESTOS:

BLDG 039 CAPSTONE

- > MECH. RM. BASEMENT, 2--16, 1280 LIN FT
- > COLD WATER PIPE MECH. RM. 1 150 LIN. FT
- > PIPING BASEMENT TO 17 FLOOR 6 LIN FT
- > MECH RM#2 BEHIND COLD WATER TANK 20 LIN. FT
- > SPRAY ON BEAMS OVER BUILDING 120,000 SQ. FT.
- > HOT WATER TANK MECH. RM #2 420 SQ. FT.
- > MECH. RM. #1,2, STORAGE CLOSETS ON FLOORS 2-16 210 SQ. FT.
- > INSIDE DOORS OF DORMITORY, ROOMS 2-16 MEN, WOMEN BATHRMS 16,000 SQ. FT.
- > UPPER CEILING 18TH FLOR IN RESTAURANT, ELEVATOR 30,000 SQ. FT.
- > CEILINGS 2-17 3,000 SQ. FT.
- > COLD WATER TANK MECH. RM. #2 150 SQ. FT.
- > FLANGE BOX 3,8,14TH FLOOR 75 SQ. FT.
- > MECH. RM #2 OVERHEAD DOOR 10 SQ. FT.
- > HEAT EXCHANGERS MECH RM #125 SQ FL.
- > MECH RM. # 1 HOT WATER TANKS 8 LIN. FT.
- > MECH RM 31 CHILL WATER SUPPLY & RETURNS 165 SQ. FT.
- > COLD WATER & CHILL ELBOWS MECH. RM 280 LIN FT.

THE FOLLOWING COMMON TYPES OF BUILDING COMPONENTS COULD CONTAIN MATERIALS THAT, WHEN DISTURBED, MIGHT EXPOSE YOU TO ASBESTOS:

1. FLOOR TILE

2. PIPE INSULATION
3. BLACK MASTIC
4. HVAC DUCT MASTIC
5. SPRAYED-ON FIREPROOFING
6. SPRAYED-ON CEILINGS
7. SHEETROCK JOINT COMPOUND

BEFORE DISTURBING THESE TYPES OF COMPONENTS, CONFIRM THAT THEY DO NOT CONTAIN ASBESTOS AND TAKE PROPER PRECAUTIONS AT ALL TIMES

06-AUG-10 2009-10-29 BLDG COMPONENT ASBESTOS/LEAD EXPOSURE UPDATE

BELOW ARE THE ASBESTOS AND LEAD TESTING RESULTS FOR CAPSTONE:

SHEET ROCK: NEGATIVE FOR ASBESTOS CONTAINING MATERIALS

JOINT COMPOUND: NEGATIVE FOR ASBESTOS CONTAINING MATERIALS

FIREPROOFING: POSITIVE FOR ASBESTOS CONTAINING MATERIAL

WHITE WALL PAINT: NEGATIVE FOR LEAD BASE PAINT

PER THE WALK THRU WITH ROBERT REALYVAQUEZ, AS LONG AS THE CONTRACTOR RUNS THE SINGLE

WIRE WITHIN THE MIDDLE OF THE CEILING, CONTRACTORS WILL NOT HAVE TO WORRY ABOUT

THE FIREPROOFING ON BOTH SIDES OF THE CEILING SPACE. THIS MATERIAL INTACT SHOULD NOT BE TOUCHED

THERE IS FIREPROOFING ON A BEAM ON THE MAIN FLOOR NEAR THE CAFÉ SIDE, AND NEAREST THE

ELECTRICAL CLOSEST NEAREST THE ELEVATOR

THE KEYSTONE ROOM HAS ASBESTOS FIREPROOFING AND ACCESS ABOVE THE CEILING IN THIS ROOM IS PROHIBITED

ALL OF THE 17TH FLOOR IS SPRAYED WITH ASBESTOS FIREPROOFING, ANAD ACCESS ABOVE THE

CEILING IN THE BOARD OF TRUSTEES MEETING ROOM IS PROHIBITED

THE HOTEL ROOMS ON THE SAME FLOOR HAVE ASBESTOS SPRAYED INSIDE EACH ROOM ABOVE THE

CEILING AS WELL AS THE HALLWAY SPACE

THE FLOOR TILE AND MASTIC IN THIS BUILDING IS POSITIVE FOR ASBESTOS THROUGHOUT

IF ANY DRILLING HAS TO OCCUR IN THIS BUILDING THE JOINT COMPOUND HAS TO BE MISSED IN

ORDER TO PURSUE WORK

IF YOU AND/ OR CONTRACTORS NEED TO DISTURB ANY MATERIALS YOU DEEM SUSPECT THAT ARE NOT LISTED ABOVE, STOP WORK AND CONTACT THE ASBESTOS PROGRAM MANAGER, 777-1208. IF YOU NEED TO DISTURB ANY MATERIAL LISTED AS POSITIVE, YOU MUST CONTACT THE ASBESTOS PROGRAM MANAGER TO ARRANGE FOR REMOVAL. THIS INFORMATION MUST BE PASSED ALONG TO ALL CONTRACTORS, SUB-CONTRACTORS, AND INDIVIDUALS WORKING IN THIS BUILDING

SECTION 08 44 13 GLAZED ALUMINUM CURTAIN WALL

PART 1 GENERAL

1.01 Work Included

- A. Furnish and install architectural aluminum curtain wall complete with related components as shown on drawings and specified in this section.
- B. A proposal drawing showing full size details of all curtain wall components including all anchors and building attachments.
- C. Test reports documenting compliance with requirements of Section 1.05.
- D. Glass
 - 1. Reference Section 08 81 00 for Glass and Glazing.
- E. Single Source Requirement
 - 1. All products listed in Section 1.02 shall be by the same manufacturer.

1.02 Related Work

- A. Exterior Canopies – Section 084413A

1.03 Laboratory Testing and Performance Requirements

- A. Test Units
 - 1. Air, water, and structural test unit size shall be a minimum of two stories high and three lites wide.
 - 2. Thermal test unit sizes shall be 80" (2032 mm) wide x 80" (2032 mm) high with one intermediate vertical mullion and two lites of glass.
- B. Test Procedures and Performance
 - 1. Air Infiltration Test
 - a. Test unit in accordance with ASTM E 283 at a static air pressure difference of 6.24 psf (300 Pa).
 - b. Air infiltration shall not exceed .06 cfm/SF (.31 l/s•m²) of unit.
 - 2. Water Resistance Test
 - a. Test unit in accordance with ASTM E 331.
 - b. The test for static water penetration (ASTM E 331) shall be conducted at an air pressure difference of 15.0 psf (720 Pa). There shall be no water leakage as defined by AAMA 501.1, paragraph 5.5.
 - 3. Uniform Load Deflection Test
 - a. Test in accordance with ASTM E 330.
 - b. Deflection under design load shall not exceed L/175 for spans less than 162" (4114 mm).
 - c. Deflection under design load shall not exceed L/240 +1/4" (6 mm) for spans greater than 162" (4114 mm).
 - 4. Uniform Load Structural Test
 - a. Test in accordance with ASTM E 330 at a pressure 1.5 times the design wind pressure in 1.05.B.3.b.
 - b. At conclusion of the test there shall be no glass breakage, permanent damage to fasteners, curtain wall parts, or any other damage that would cause the curtain wall to be defective.
 - 5. Condensation Resistance Test (CRF)
 - a. Test unit in accordance with AAMA 1503.1.
 - b. Condensation Resistance Factor (CRF) shall not be less than 68 (frame) when glazed with .24 center of glass U-Factor. (See chart at end of section).

6. Thermal Transmittance Test (Conductive U-Factor)
 - a. With ventilators closed and locked, test unit in accordance with NFRC 100-2010.
 - b. Conductive thermal transmittance (U-Factor) shall not be more than .38 BTU/hr•ft²•°F (2.16 W/m²•K) when glazed with .24 center of glass U-Factor. (See chart at end of section).
 7. Seismic Performance
 - a. Test unit in accordance to AAMA 501.4 system to meet design displacement of 0.010 x the greater adjacent story height and ultimate displacement of 1.5 x the design displacement.
 8. Sound Transmission Loss
 - a. Test unit in accordance with ASTM E 90-02.
 - b. Sound Transmission Class (STC) shall not be less than 29.
- C. Project Wind Loads – 90 mph, 3 second gust.

1.06 Field Testing and Performance Requirements

1.07 Quality Assurance

- A. Provide test reports from AAMA accredited laboratories certifying the performance as specified in 1.05.
- B. Test reports shall be accompanied by the curtain wall manufacturer's letter of certification stating that the tested curtain wall meets or exceeds the referenced criteria for the appropriate curtain wall type.

1.08 References

1.09 Submittals

- A. Contractor shall submit shop drawings; finish samples, test reports, and warranties.
 1. Samples of materials as may be requested without cost to owner, i.e., metal, glass, fasteners, anchors, frame sections, mullion section, corner section, etc.

1.10 Warranties

- A. Total Curtain Wall Installation
 1. The responsible contractor shall assume full responsibility and warrant for one year the satisfactory performance of the total curtain wall installation. This includes the glass (including insulated units), glazing, anchorage and setting system, sealing, flashing, etc. as it relates to air, water, and structural adequacy and the specifications and approved shop drawings.
 2. Any deficiencies due to such elements not meeting the specifications shall be corrected by the responsible contractor at their expense during the warranty period.
- B. Window Material and Workmanship
 1. Provide written guarantee against defects in material and workmanship for 3 years from the date of final shipment.
- C. Glass
 1. Provide written warranty for insulated glass units, that they will be free from obstruction of vision as a result of dust or film formation on the internal glass surfaces caused by failure of the hermetic seal due to defects in material and workmanship.
 2. Warranty period shall be for 10 (ten) years.
- D. Finish

1. Warranty period shall be for 10 years from the date of final shipment.

PART 2 PRODUCTS

2.01 Materials

- A. Curtainwall system shall be EFCO Series 5600 2.5" x 6" and 4" x 6" outside glazed, or a comparable product by one of the following:
 1. Kawneer North America
 2. Traco
 3. Vistawall Architectural Products
- B. Aluminum
 1. Extruded aluminum shall be 6063-T6 alloy and temper.
- C. Glass – as specified in section 088100
- D. Anchors
 1. Perimeter and floor line anchors shall be aluminum or steel. All steel anchors shall be properly insulated from the aluminum.
- E. Thermal Barrier
 1. The thermal barrier shall be extruded PVC used as an applied thermal isolator.

2.02 Fabrication

- A. General
 1. All aluminum vertical and horizontal extrusions shall have a minimum wall thickness of .093" (2.3 mm) to .125" (3 mm).
- B. Frame
 1. Frame components shall be mechanically fastened by means of extruded aluminum shear blocks attached to vertical mullions.
 2. Curtain wall system is able to accommodate separate interior and exterior finishes and colors.
- C. Glazing
 1. Outside glazed curtain wall system shall be dry glazed with an exterior aluminum pressure plate and snap cover with interior and exterior dense EPDM preset gaskets.
- D. Finish
 1. Anodic
 - a. Finish all exposed areas of aluminum windows and components with electrolytically deposited color in accordance with Aluminum Association Designation AA-M10-C22-A44 Color shall be dark bronze.

2.03 Entrance Door Systems

- A. Entrance Doors: Manufacturer's standard glazed entrance doors for manual-swing operation.
 1. Door Construction: **1-3/4-inch (44.5-mm)** overall thickness, with minimum **0.125-inch (3.2-mm-)** thick, extruded-aluminum tubular rail and stile members. Mechanically fasten corners with reinforcing brackets that are deeply penetrated and fillet welded or that incorporate concealed tie rods.

- a. Thermal Construction: Non-Thermal .
 2. Door Design: Narrow stile; 2-1/8-inch (54-mm) nominal width
 - a. Accessible Doors: Smooth surfaced for width of door in area within 10 inches (255 mm) above floor or ground plane.
 3. Glazing Stops and Gaskets: Square, snap-on, extruded-aluminum stops and preformed gaskets.
 - a. Provide non-removable glazing stops on outside of door.
- B. Door Hardware Balance: As specified below and in Division 08 Section "Door Hardware."
- C. Entrance Door Hardware:
1. General: Provide entrance door hardware for each entrance door to comply with requirements in this Section.
 - a. Entrance Door Hardware Sets: Provide quantity, item, size, finish or color indicated, and products complying with BHMA standard referenced.
 - b. Sequence of Operation: Provide electrified door hardware function, sequence of operation, and interface with other building control systems indicated.
 - c. Opening-Force Requirements:
 - 1) Egress Doors: Not more than 15 lbf (67 N) to release the latch and not more than 30 lbf (133 N) to set the door in motion and not more than 15 lbf (67 N) to open the door to its minimum required width.
 2. Opening-Force Requirements:
 - a. Latches and Exit Devices: Not more than 15 lbf (67 N) required to release latch.
 3. Continuous-Gear Hinges: Manufacturer's standard with stainless-steel bearings between knuckles, fabricated to full height of door and frame.
 4. Weather Stripping: Manufacturer's standard replaceable components.
 5. Weather Sweeps: Manufacturer's standard exterior-door bottom sweep with concealed fasteners on mounting strip.
 6. Silencers: BHMA A156.16, Grade 1.
 7. Thresholds: BHMA A156.21, raised thresholds beveled with a slope of not more than 1:2, with maximum height of 1/2 inch (13 mm).
 8. Finger Guards: Manufacturer's standard collapsible neoprene or PVC gasket anchored to frame hinge-jamb at center-pivoted doors.

2.04 Exterior Canopies:

1. See specification section 084413A for Canopies. These canopies shall be supplied and furnished as a part of the Curtain Wall System.

PART 3 EXECUTION

3.01 Inspection

- A. Job Conditions
 - 1. All openings shall be prepared by others to the proper size and shall be plumb, level, and in the proper location and alignment as shown on the architect's drawings.
 - 2. Provide for manufacturer representation to conduct pre-installation site meeting.

3.02 Installation

- A. Use only skilled tradesmen with work done in accordance with approved shop drawings and established specifications, and erect all curtain wall components to all building bench marks and column center lines.
- B. Plumb and align curtain wall faces in a single plane for each wall plane, and erect curtain wall materials square and true. Adequately anchor to maintain positions permanently when subjected to normal thermal movement, building movement, and specified wind loads.
- C. Adjust windows in curtain wall for proper operation after installation.
- D. Furnish and apply sealants to provide a weather tight installation at all joints and intersections and at opening perimeters. Wipe off excess material, leave all exposed surfaces and joints clean and smooth.

3.03 Anchorage

- A. Adequately anchor to maintain positions permanently when subjected to normal thermal movement, specified building movement, and specified wind loads.

3.04 Protection and Cleaning

- A. The general contractor shall protect the aluminum materials and finish against damage from construction activities and harmful substances. The general contractor shall remove any protective coatings as directed by the architect, and shall clean the aluminum surfaces as recommended for the type of finish applied.

END OF SECTION

084413A EXTERIOR CANOPY

PART 1 GENERAL

1.01 Work Included

- A. Furnish and install architectural aluminum curtain wall complete with integral exterior canopy device and related components as shown on drawings and specified in this section.
- B. Canopy shall be designed as an integral part of the Curtain Wall System.
 - 1. A proposal drawing showing full size details of all canopy and curtain wall components including all anchors, sunshade supports, and building attachments.
 - 2. Engineering calculations documenting compliance with requirements of Section 1.05.
- C. Glass
 - 1. Reference Section 08 81 00 for Glass and Glazing.
- D. Single Source Requirement
 - 1. All products listed in Section 1.02 shall be by the same manufacturer.

1.02 Related Work

1.03 Submittals

- A. Contractor shall submit (3) copies of all shop drawings to the architect for his approval. Drawings shall show scale elevations and sections. Full size sections shall be shown only when needed for clarity. Drawings shall show construction of all parts of the work, including metal and glass thickness, methods of joining, details of all field connections and anchorage, fastening and sealing methods, metal finishes, and all pertinent information. Relationship to other work should be clearly indicated. No work shall be fabricated until shop drawings for that work have been finally approved for fabrication.
- B. Contractor shall submit finish samples, test reports, and warranties.
 - 1. Samples of materials as may be requested without cost to owner, i.e., metal, glass, fasteners, anchors, frame sections, mullion section, corner section, etc.
- C. Shop drawings shall be submitted as a part of the Curtain Wall System and shall be stamped by an engineer registered in the State of South Carolina.

1.04 Warranties

- A. Total Curtain Wall System
 - 1. The responsible contractor shall assume full responsibility and warrant for one year the satisfactory performance of the total curtain wall installation. This includes the glass (including insulated units), glazing, sunshade device anchorage and setting system, sealing, flashing, etc. as it relates to air, water, and structural adequacy and the specifications and approved shop drawings.
 - 2. Any deficiencies due to such elements not meeting the specifications shall be corrected by the responsible contractor at their expense during the warranty period.

PART 2 PRODUCTS

2.01 Materials

- A. Aluminum
 - 1. Extruded aluminum shall be 6063-T6 alloy and temper.
- B. Dissimilar Metals
 - 1. All dissimilar metals must be properly insulated to prevent galvanic action.
- C. Fasteners
 - 1. All exposed fasteners shall be aluminum, stainless steel, or zinc plated steel.
- D. Anchors
 - 1. Perimeter and floor line anchors shall be aluminum or steel. All steel anchors shall be properly insulated from the aluminum

2.02 Fabrication

- A. General
 - 1. Canopy cover shall be .125 Aluminum
 - 2. Canopy "arms" and mullion clips shall be extrusions with a nominal wall thickness of .25" (6 mm).
- C. Finish – Anodic . Finish all exposed areas with electrolytically deposited color in accordance with Aluminum Association Designation AA-M10-C22-A44.

PART 3 EXECUTION

3.01 Inspection

- A. Job Conditions
 - 1. All openings shall be prepared by others to the proper size and shall be plumb, level, and in the proper location and alignment as shown on the architect's drawings.

3.02 Installation

- A. Use only skilled tradesmen with work done in accordance with approved shop drawings and established specifications, and erect all curtain wall components to all building bench marks and column center lines.
- B. Plumb and align curtain wall faces in a single plane for each wall plane, and erect curtain wall materials square and true. Adequately anchor to maintain positions permanently when subjected to normal thermal movement, building movement, and specified wind loads.
- C. Adjust windows in curtain wall for proper operation after installation.
- D. Furnish and apply sealants to provide a weather tight installation at all joints and intersections and at opening perimeters. Wipe off excess material, leave all exposed surfaces and joints clean and smooth.

3.03 Anchorage

- A. Adequately anchor to maintain positions permanently when subjected to normal thermal movement, specified building movement, and specified wind loads.

3.04 Protection and Cleaning

- A. The general contractor shall protect the aluminum materials and finish against damage from construction activities and harmful substances. The general contractor shall remove any protective coatings as directed by the architect, and shall clean the aluminum surfaces as recommended for the type of finish applied.

END OF SECTION

SECTION 122216 - DRAPERY TRACK AND ACCESSORIES

PART 1- GENERAL

1.1 SUMMARY

- A. Section Includes:
 - 1. Electronic drive drapery track systems.
 - 2. Drapery control system.

1.2 REFERENCES

- A. Association of Electrical and Medical Imaging Equipment Manufacturers (NEMA) WD1-1999 (R2005) - General Color requirements for Wiring Devices.
- B. ASTM International (ASTM) - D4674-89 - Standard Test Method for Accelerated Testing for Color Stability of Plastics Exposed to Indoor Fluorescent Lighting and Window-Filtered Daylight.
- C. National Fire Protection Association (NFPA) 70 (2008) - National Electrical Code.

1.3 SYSTEM DESCRIPTION

- A. Drapery System: Ultra-quiet, precision-controlled electronic drive unit hidden behind draperies, controlling drapery movement.
- B. Track System: Single drapery track.
- C. Track Configuration: Straight.
- D. Track Operation: Tandem draw, left and right-mounted electronic drive unit.
- E. Track System Capacity: 175 pounds.
- F. Drapery Style: Pinch pleat.
- G. Controls: Wall mounted and remote control.

1.4 SUBMITTALS

- A. Submittals for Review:
 - 1. Shop Drawings: Include following for each drapery track required:
 - a. Drapery locations by room name and number using Architect's plan numbers.
 - b. Description of track system, direction of draw, and track operation.
 - c. Attachments and accessories.
 - d. Electronic drive unit and control locations.
 - e. Low voltage wiring diagrams with system components.
 - f. Power supply locations.
 - 2. Product Data: Include product descriptions, electronic drive unit attributes, control station descriptions, and operational characteristics.

3. Samples: 6 inch long drapery track samples showing profile and finish.

- B. Closeout Submittals:
1. Operation and Maintenance Data.

1.5 QUALITY ASSURANCE

- A. Manufacturer Qualifications:
1. Minimum 5 years experience in manufacture of low-voltage motorized shading systems.
2. Provide single source for shading system and control systems.
- B. Installer Qualifications: Qualified by factory training and previous experience to install and commission specified products.
- C. Perform work in accordance with NFPA 70.
- D. Pre-Installation Conference:
1. Convene at site two (2) weeks prior to beginning work of this Section.
2. Attendance: Architect, Interior Designer & Contractor and drapery track system installer.
3. Review and discuss:
a. Product delivery and storage.
b. Staging and sequencing.
c. Interface with adjacent work.
d. Protection of completed work.

1.6 DELIVERY, STORAGE AND HANDLING

- A. Include installation, programming, and maintenance instructions in product packaging.

1.7 PROJECT CONDITIONS

- A. Do not install drapery track systems until overhead and adjacent work is completed.

1.8 WARRANTIES

- A. Provide manufacturer's 2 year warranty covering parts and labor and 8 year limited parts warranty covering repair or replacement of defective equipment.

1.9 MAINTENANCE

- A. Manufacturer:
1. Provide 24-hour, 7-day technical support for troubleshooting and programming.
2. Make replacement parts available for minimum of 10 years after date of manufacture.

PART 2 - PRODUCTS

2.1 MANUFACTURERS

- A. Contract Documents are based on Sivoia QS Drapery Systems by Lutron Electronics Co., Inc.

B. Substitutions:

1. All proposed substitutions (clearly delineated as such) must be submitted in writing for approval by the design professional a minimum of 15 working days prior to the bid date and must be made available to all bidders. Proposed substitutes must be accompanied by a review of the specification noting compliance on a line-by-line basis.
2. By using pre-approved substitutions, the contractor accepts responsibility and associated costs for all required modifications to circuitry, devices, and wiring. The contractor shall provide complete engineered shop drawings (including power wiring) with deviations for the original design highlighted in an alternate color to the engineer for review and approval prior to rough-in.

2.2 COMPONENTS

A. Drapery Track System Components:

1. Tracks:
 - a. Extruded aluminum with drive belts, idler gear housings, master carriers, auxiliary carriers, covers, and mounting brackets to suit system layout.
 - b. Color-matched end caps.
 - c. Concealed splicing bars.
 - d. Optional manual-open master carrier with field-adjustable spring release.
2. Electronic drive units:
 - a. Operate independently, without use of external group controllers.
 - b. Audible noise: Maximum 44 dBA measured 3 feet from operator drive unit.
 - c. Power: 24 VDC, approved power supply via NEC Class 2 power source.
3. Controls: Low voltage keypad and Contact closure input powered from electronic drive unit.

B. System Performance:

1. One-touch control of draperies by means of keypad or infrared remote.
2. Store up to 250 programmable stop points including open, close, and any other position.
3. Presets set by 5-second button push and hold from keypad, contact closure input, or handheld remote control.
4. Presets recalled by keypad, contact closure input, infrared receiver, or other lighting control system interface.
5. Keypad adjustment of presets disabled using lockout feature on keypad.
6. Open and close limits programmable from electronic drive unit, wall-mounted keypad, or handheld remote control.
7. 10 year power failure memory.
8. System components electro static discharge protected.

C. Grouping:

1. Keypads and contact closure inputs can control any electronic drive unit without separate group controller.
2. System groups and subgroups configured at point of control without rewiring and without access to electronic drive unit.
3. System may contain multiple electronic drive units.
4. Keypads and interfaces able to operate any group or subgroup of electronic drive units.
5. Controls able to operate any group or subgroup of electronic drive units regardless of window or drapery treatment type.

D. Integration:

1. Electronic drive units integrate with lighting controls without separate interface.

2. Contact closure, RS232, and Ethernet interfaces available to interface with audio/visual equipment and security systems. Coordinate required with AV consultant and provide accordingly.
- E. System Controls:
1. Drapes controlled by built-in shading columns on lighting control or by keypad.
 2. Electronic drive units, keypads, and lighting controls contain microprocessors, allowing high level programming from any source.
 3. Drapery tracks, window shades, lighting controls, and keypads wired together on same communications link.
- F. Wall Mounted Controls:
1. Low voltage keypads:
 - a. Electronically set and reconfigure drapery track open and close limits, drapery preset positions, system groups, and system subgroups without rewiring or access to electronic drive unit.
 - b. Fit into standard electrical box.
 2. Face plates:
 - a. Attach without visible means of attachment.
 - b. Engraved artwork.
 3. Product color: Match NEMA WD1.
 4. Provide immediate local LED response upon button activation.
 5. Backlit buttons.
 6. Removable button assemblies allowing field changes.
 7. Capable of simultaneously controlling one or more draperies or shades.
 8. Type: Two locations with two button with raise/lower and 1 location with 3 group, two button with raise/lower.
- G. Power Supplies:
1. Electronic drive units powered with 24 VDC from approved power supply; power supply via NEC Class 2 power source.
 2. Provide power panel including 10 outputs.

2.3 FINISHES

- A. Track and Accessories: Clear anodized.
- B. Keypads: color [to be selected from manufacturer's full color range].

PART 3 - EXECUTION

3.1 INSTALLATION

- A. Install in accordance with manufacturer's instructions and approved Shop Drawings.
- B. Install drapery systems to provide smooth operation.
- C. Locate controls where shown on Electrical drawings.
- D. Connect to power supply and control wiring.

E. Connect to both lighting control and audio/visual system.

3.2 ADJUSTING

A. Adjust for smooth, quiet operation.

3.3 DEMONSTRATION

A. Demonstrate proper operation and maintenance of drapery systems to Owner.

3.4 SCHEDULE

A. Campus Room:

1. Track system: Dual drapery track.
2. Track configuration: Double Bend.
3. Track operation: Tandem draw, left and right-mounted electronic drive unit.
4. Track system capacity: 175 pounds.
5. Drapery style: Pinch pleat.
6. Controls: Wall-mounted and remote control.

END OF SECTION

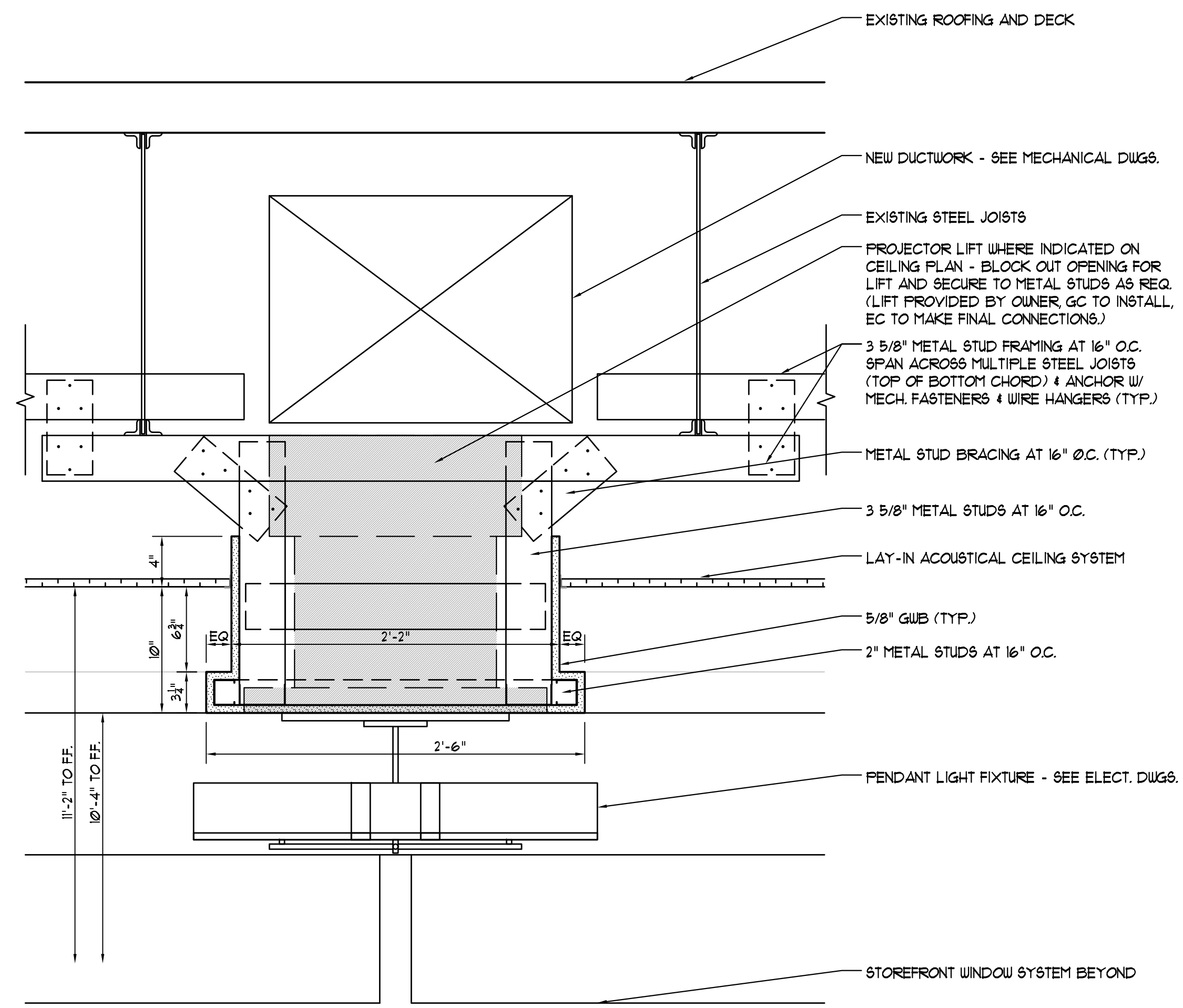

1
1-7
CEILING DETAIL
SCALE: 1 1/2" = 1'-0"

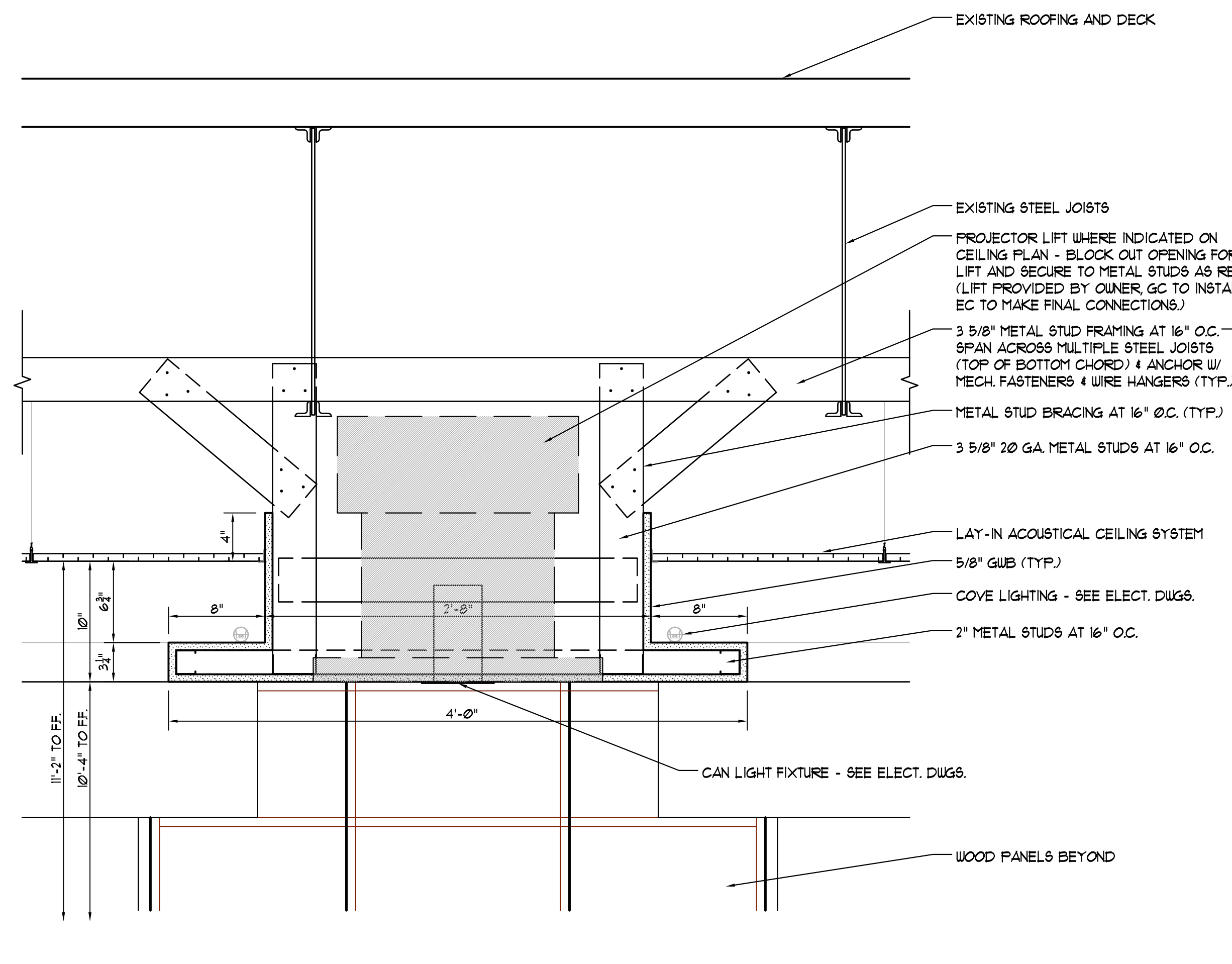

2
1-7
CEILING DETAIL
SCALE: 1 1/2" = 1'-0"

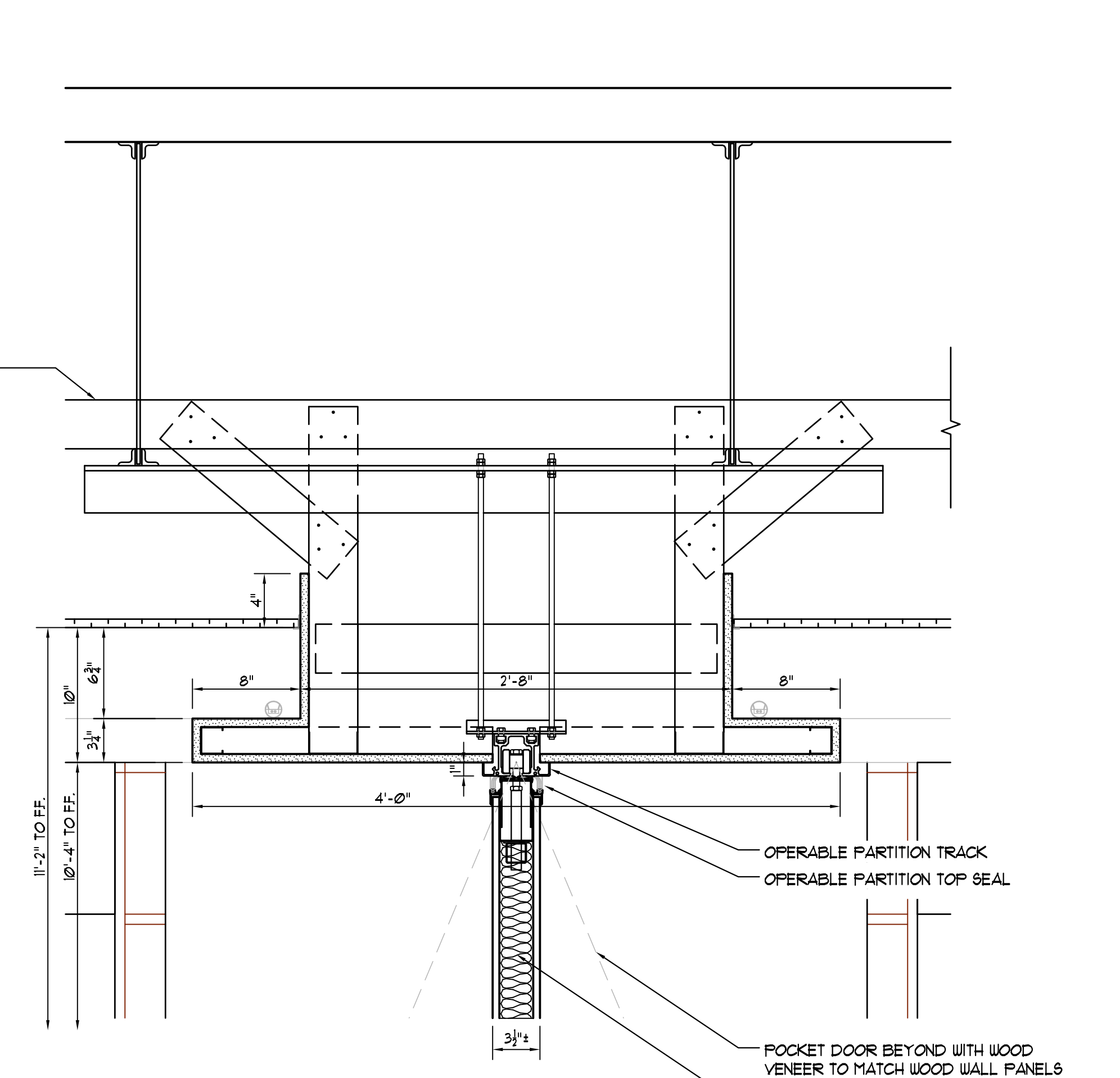

3
1-7
CEILING DETAIL
SCALE: 1 1/2" = 1'-0"
SEE 2/1-1 FOR TYP. NOTES

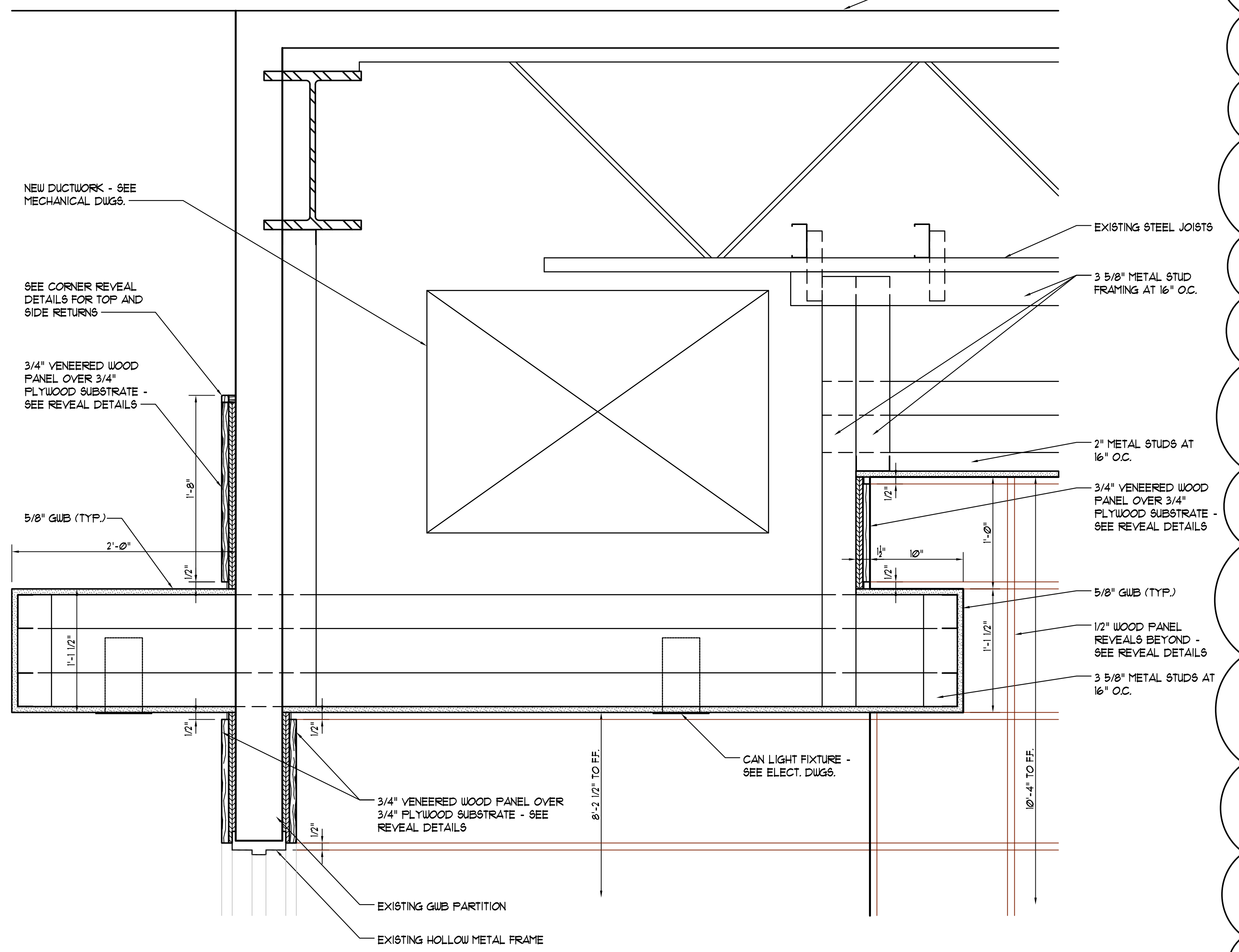

4
1-7
CEILING DETAIL
SCALE: 1 1/2" = 1'-0"

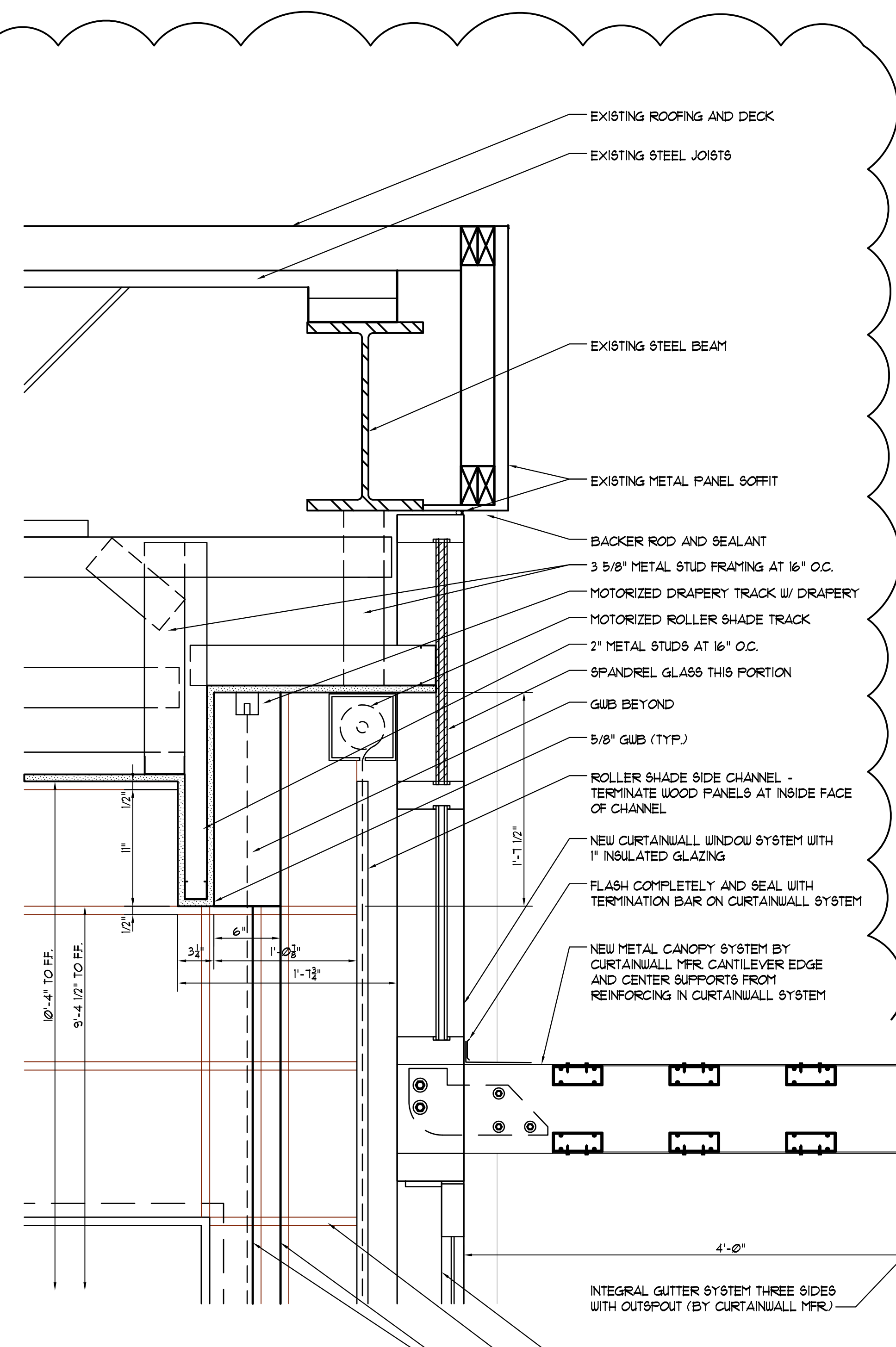

5
1-7
CEILING DETAIL
SCALE: 1 1/2" = 1'-0"

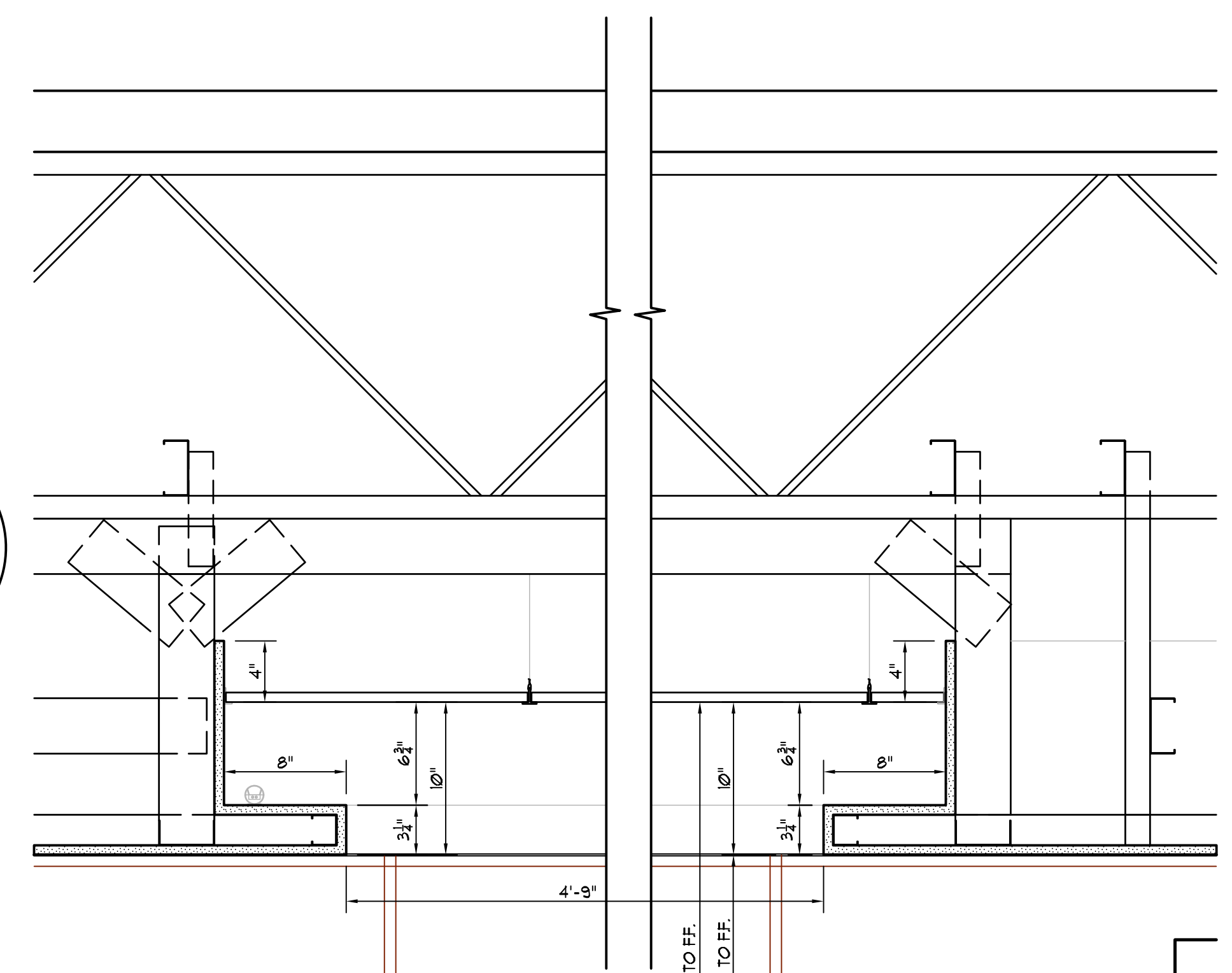

6
1-7
CEILING DETAIL
SCALE: 1 1/2" = 1'-0"
SEE 2/1-1 FOR TYP. NOTES

These drawings are the property of Jumper Carter Sease Architects, PA and may not be reproduced, copied or used in whole or in part without written consent of the architect and any infringement will be subject to legal action.



800 Columbiana Drive, Suite 208 • Irmo, SC • 29063 • 803-765-1007 • www.simgroupusa.com

**UNIVERSITY OF SOUTH CAROLINA
CAPSTONE CAMPUS ROOM UPGRADES
ADDENDUM NO. 2 - ELECTRICAL ITEMS
March 16, 2012**

This addendum modifies the Contract Documents only in the manner and to the extent stated herein and shown on any accompanying drawings and will become a part of the Contract Documents. Except as specified or otherwise indicated by this addendum, all work shall be in accordance with the basic requirements of the Contract Documents.

SPECIFICATIONS:

1. **SECTION 260500 - ELECTRICAL BASIC MATERIALS AND METHODS:**

- Add the following paragraph to 1-01 SCOPE OF WORK:

Provide an Arc Flash Hazard Analysis, per the latest version of the Standard for Electrical Safety in the Workplace, NFPA 70E. An arc flash hazard analysis shall determine the Arc Flash Protection Boundary and the personal protective equipment that people within the Arc Flash Boundary shall use. Field install Arc Flash and Shock Warning labels on each piece of new electrical distribution equipment such as panelboards, safety switches, motor control centers, and automatic transfer switches. The labels will indicate the flash hazard boundary, the flash hazard at 18 inches, the PPE level requirements, and the approach restrictions.

DRAWINGS:

2. **SHEET E001 ELECTRICAL DETAILS:**

- Add the attached Lighting Controls Riser Diagram.

3. **SHEET E201 POWER PLAN:**

- In Ballroom 101A and Ballroom 101B add a second controller adjacent to the screen controller shown (match what is shown in Ballroom 101C). Add the following note referencing all three controller locations:

Denotes control location for screen controls, roller shade and drapery controls, and lighting controls (Graphic Eye). Screen controls and shade controls furnished by GC, installed and wired by EC. Graphic Eye lighting controls furnished, installed, and wired by EC. Provide backboxes 48" aff to top of box per mfr's instructions (4 gang box required for Graphic Eye lighting controls). Verify locations and wiring requirements prior to starting work.

Each Bidder shall acknowledge receipt of this Addendum and all other Addenda on his bid form.