

# THE UNIVERSITY OF SOUTH CAROLINA

## BASIC LASER SAFETY

**A laser safety course for The University of South Carolina  
laser operators**

Revised:  
7/1/2011

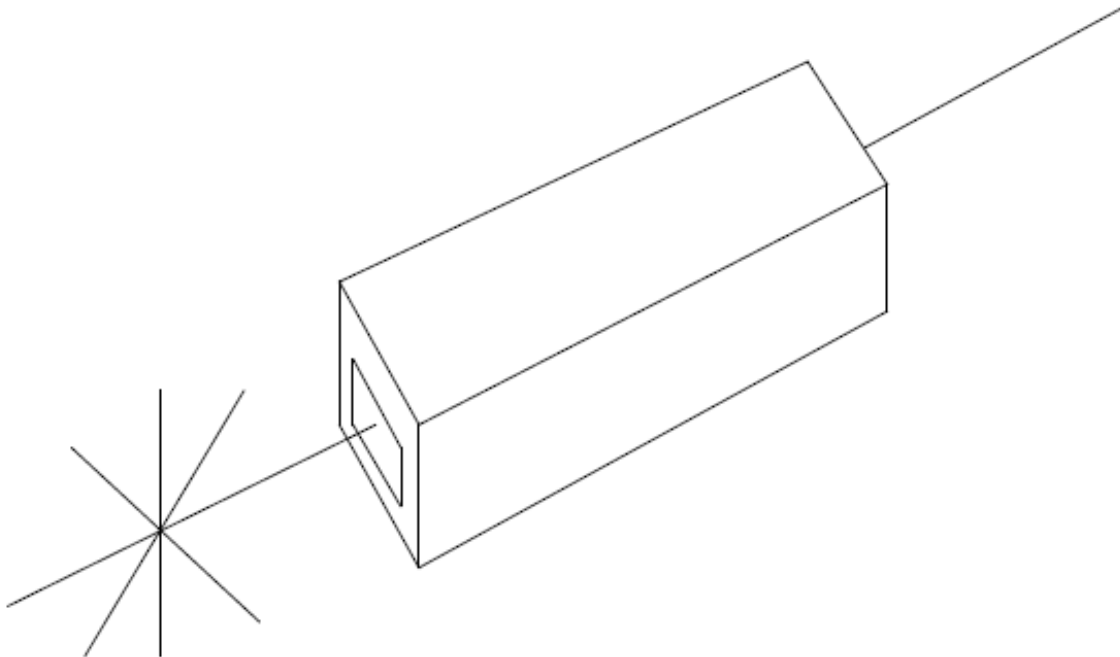

Developed by: The University of South Carolina Radiation Safety Office

# Basic Laser Safety

## Lesson 1

- Review of Light Waves
- Unique Characteristics of Laser Light
- How a Laser Works
- Properties that Affect Safety
- Types of Lasers
- Laser Classification

## Lesson 2

- Light Waves in the Electromagnetic Spectrum
- How Light Interacts with Materials
- Reflection and Mirrors
- Refraction of Transmitted Light
- Absorption of Transmitted Light
- Light Measurements for Laser Safety

## Lesson 3

- Laser Damage in Human Tissue
- Eye Injuries
- Skin Injuries
- Hazardous Levels of Laser Exposure
- Related Hazards

## Lesson 4

- Safety Controls
- Hazard Classification and Corresponding Controls
- Hazard Evaluation
- Control Measures
- Safety Standards
- Employer/Employee Responsibilities

# Table of Contents

A laser safety course for The University of South Carolina laser operators.....	1
<b>Basic Laser Safety .....</b>	<b>2</b>
Lesson 1 .....	2
Lesson 2 .....	2
Lesson 3 .....	2
Lesson 4 .....	2
<b>Lesson 1: Laser Fundamentals.....</b>	<b>1</b>
Review of Light Waves .....	1
Stimulated Emission .....	2
The Unique Characteristics of Laser Light .....	3
How a Laser Works.....	4
A. Active Medium .....	5
B. Excitation Mechanism .....	5
C. Optical Resonator.....	5
D. Output Coupler .....	5
Properties That Affect Safety.....	6
A. Wavelength .....	6
B. Exposure Duration .....	6
C. Output power.....	7
Types of Lasers .....	8
A. Gas Lasers .....	8
B. Solid Lasers.....	9
C. Semiconductor Lasers .....	9
D. Dye Lasers .....	10
Laser Classification System .....	11
<b>Lesson 2: Light and Optics.....</b>	<b>12</b>
Light Waves in the Electromagnetic Spectrum.....	12
How Light Interacts With Materials .....	12
Reflection and Mirrors.....	13
Refraction of Transmitted Light: Lenses .....	15
Absorption of Transmitted Light: Filters and Laser Eyewear .....	16
Light Measurements for Laser Safety .....	18
<b>Lesson 3: LASER HAZARDS .....</b>	<b>19</b>

Laser Damage in Human tissue .....	19
Eye Injuries .....	20
A. Parts of the Eye .....	20
B. Exposure Duration .....	20
C. Other Effects .....	21
Skin Injuries .....	21
Hazardous Levels of Laser Exposure.....	22
Related Hazards .....	22
A. Electric shock is the most dangerous related hazard.....	22
B. Hazardous Materials.....	23
C. Fire Hazards .....	23
<b>Lesson 4: Laser Safety Practices and Controls.....</b>	<b>24</b>
<b>Safety Controls.....</b>	<b>24</b>
A. Engineering controls.....	24
B. Administrative Controls.....	24
C. Personnel Protective Equipment.....	27
<b>Hazard Classification and Corresponding Controls.....</b>	<b>28</b>
A. Class I-Exempt .....	28
B. Class II .....	28
C. Class III .....	28
D. Class IV.....	29
<b>Hazard Evaluation .....</b>	<b>29</b>
A. Hazards Associated with Laser Equipment.....	29
B. Hazards Associated with the Laser Environment: .....	29
<b>Control Measures.....</b>	<b>30</b>
A. Work Area Controls .....	30
B. Personnel Controls .....	30
<b>Safety Standards .....</b>	<b>31</b>
<b>Employer/Employee Responsibilities.....</b>	<b>31</b>
A. Employer Responsibilities .....	31
B. Employee Responsibilities .....	31
<b>References .....</b>	<b>33</b>

# Figures

Figure #	Figure	Page #
1-1	Stimulated emission	2
1-2	Directional laser beam	3
1-3	Ordinary light	3
1-4	Coherent light	4
1-5	Incoherent light	4
1-6	Typical laser	4
1-7	Peak power	7
1-8	Gas laser	8
1-9	Solid laser	9
2-1	Diffuse reflector	13
2-2	Plane specular reflector	13
2-3	Curved specular reflector	14
2-4	Laser light on concave mirror	14
2-5	Laser light on convex mirror	14
2-6	Laser light on converging lens	15
2-7	Laser light on diverging lens	15
2-8	Neutral density filter	16
2-9	Cut-off filter	16
2-10	Bandpass filter	17
4-1	Class II label	25
4-2	Class IIIA label	25
4-3	Class IIIB label	25
4-4	Class IV label	26

# Lesson 1: Laser Fundamentals

Laser is an acronym for “Light Amplification by Stimulated Emission of Radiation.” A laser is a device that produces and amplifies light by stimulated emission. It produces light in the ultraviolet (UV), visible and infrared (IR) region of the electromagnetic spectrum.

Lasers produce a very intense light containing a concentration of power within a very narrow beam. They can be used for medical, scientific, commercial and industrial applications. Laser beams can be extremely hazardous if not understood and properly controlled.

To understand the unique characteristics of lasers, we must first review the basic principles of light.

## Review of Light Waves

Lasers are light waves. Light is a form of electromagnetic radiation. It travels through space as waves and occurs at different wavelengths. The wavelength is the distance between peaks or valleys of two waves. The color of light corresponds to the wavelength. Violet has the shortest wavelength, red has the longest wavelength and white light is a combination of all wavelengths. Laser light is different from other sources of light because it consists of a narrow range of wavelengths.

Light is produced by atomic processes which are also responsible for the generation of laser light. The atom consists of a small dense nucleus and one or more electrons in motion about the nucleus. The relationship between the electrons and the nucleus is described in terms of energy levels.

The electrons are generally found in the ground state or the lowest energy level. They can occupy higher energy levels leaving lower levels vacant. They change from one level to another by (1) absorption or (2) emission of energy. This changing of energy levels is called **radiative transition**. There are three types of radiative transition.

- A. Stimulated emission
- B. Spontaneous emission
- C. Absorption

Absorption and spontaneous emission are common occurrences in nature. Stimulated emission seldom occurs and is the basis of laser action.

## Stimulated Emission

The theory of stimulated emission was developed by Einstein in 1917 (Fig. 1-1). A photon is released from an excited atom and interacts with a similarly excited atom. The second atom de-excites itself by giving off a photon that is identical in frequency, energy, direction and phase. The triggering photon goes on its way unchanged. There are now two photons which go on to trigger more atoms through stimulated emission

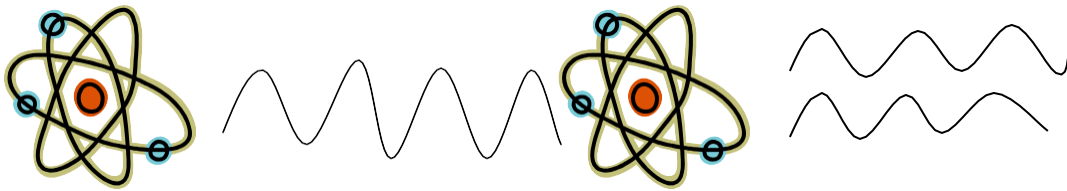

FIG.1-1

Stimulated Emission

Stimulated emission can cause amplification of a number of photons traveling in a certain direction. The direction can be controlled by placing mirrors at opposite ends of an optical cavity. The number of atoms traveling along the axis of the two mirrors increases greatly and “LIGHT AMPLIFICATION BY STIMULATED EMISSION OF RADIATION” occurs.

## The Unique Characteristics of Laser Light

Three unique characteristics of laser light differentiate it from other sources of light.

### A. Monochromaticity

Laser light is made of one (mono) color (chroma) so it is monochromatic. It is a single color with a narrow range of wavelengths.

### B. Directionality

Laser light diverges very little and travels in one direction (FIG. 1-2) as opposed to ordinary light which radiates in all directions (FIG. 1-3).



FIG. 1-2  
Directional Laser Beam



FIG. 1-3  
Ordinary Light



### C. Coherence

Waves produced by a laser travel through space in phase. The property of being in phase is called coherence (FIG. 1-4) and is responsible for the strength and intensity of the beam. Ordinary light is incoherent. There is no order to the wave pattern (FIG. 1-5).

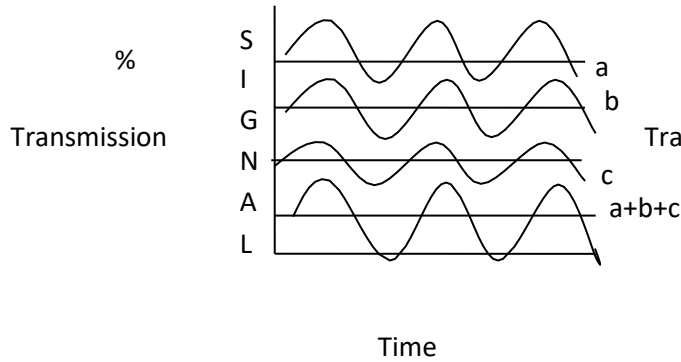

FIG. 1-4  
Coherent  
Light

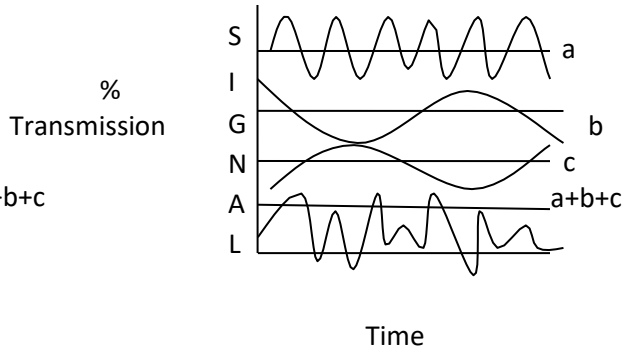

FIG. 1-5  
Incoherent  
Light

### How a Laser Works

There are four basic elements of a laser (FIG. 1-6)

- A. Active medium
- B. Excitation mechanism
- C. Optical Resonator
- D. Output coupler

Laser light is generated when a source of energy interacts with a medium which may be a solid, liquid or gas so the medium produces light. Mirrors are used to reflect light so the beam that develops is monochromatic, directional and coherent.

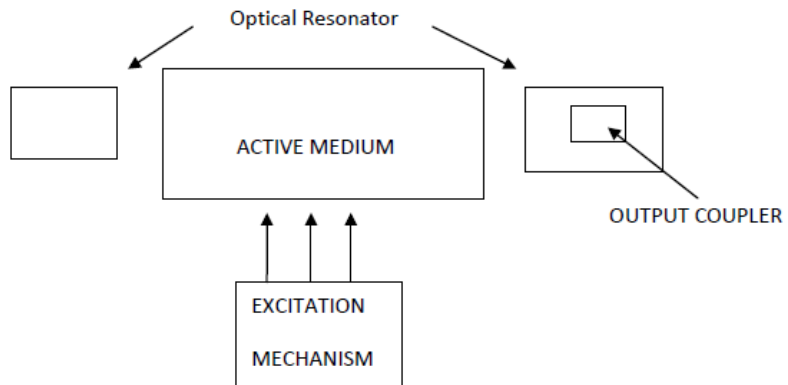

FIG. 1-6  
Typical Laser

## **A. Active Medium**

The active medium can be a solid, liquid, gas or a semiconductor. Energy is supplied to the active medium and spontaneous emission occurs where atoms in the active medium are emitting light in all directions. After a short time, an atom in the active medium emits a photon which is traveling perpendicular to the feedback mechanism and causes stimulated emission.

Light leaving the active medium and traveling to the feedback mechanism is used to produce the laser light. The active medium becomes the optical amplifier when it receives the energy from the excitation source. The light leaves the active medium at a higher power level than when it entered.

## **B. Excitation Mechanism**

The excitation mechanism is the source of energy to the laser. It can be:

1. Electrical energy from a power supply which lights the tube of a gas laser.
2. Light energy from a flashtube or lamp which pumps a solid laser.
3. Another laser that pumps a liquid dye laser.

## **C. Optical Resonator**

The optical resonator consists of two mirrors positioned at each end of the active medium and aligned to reflect light back into the active medium. This is also called the **optical cavity**. The light that leaves the end of the active medium forms the laser beam. The light must travel directly toward the mirrors so it can be reflected back and forth. As it passes back and forth in the active medium (bouncing between the mirrors), it increases in strength. Simply put, the feedback mechanism redirects the laser beam through the active medium so it can be amplified into a powerful beam.

## **D. Output Coupler**

The output coupler is a partially transparent mirror that allows a portion of the intercavity beam to leave the laser and form the beam. One of the mirrors of the feedback mechanism has a coating that is less than 100% reflective at the laser wavelength so the light is allowed to escape from the optical cavity.

## Properties That Affect Safety

### A. Wavelength

The operating wavelength of a visible laser corresponds to the color of the laser's output beam. Some lasers are invisible because their wavelength is outside the range of visible light. Light composed of wavelengths longer than visible light is called **infrared light** and light composed of wavelengths shorter than visible light is called **ultraviolet light**. The wavelength determines the actual site where damage occurs because certain parts of the eye and skin are more easily damaged by visible light and others are damaged by longer or shorter wavelengths.

### B. Exposure Duration

The duration of the exposure is very important in determining hazards.

1. **Continuous wave (CW)** lasers produce a constant flow of light. The output remains constant over time.
2. **Pulse lasers** release light energy in short, intense bursts. The output changes greatly over a given period of time.

#### a. Pulse Repetition Rate (PRR)

Pulsed lasers operate so they produce repetitive pulses. The number of pulses in a given period of time is the pulse repetition rate (PRR). The PRR is important in determining exposure. The greater the PRR is, the greater the damage.

### b. Q-switched Lasers

Q-switched lasers are pulsed lasers. A q-switch is a shutter placed between the mirrors of a laser to interrupt or prevent lasing action by blocking reflectance. The active medium then builds up energy that is released as a very intense pulse.

The **peak power** is used in determining the hazard of a Q-switched laser. The peak power is the greatest amount of energy released in a very short period of time. (FIG. 1-7).

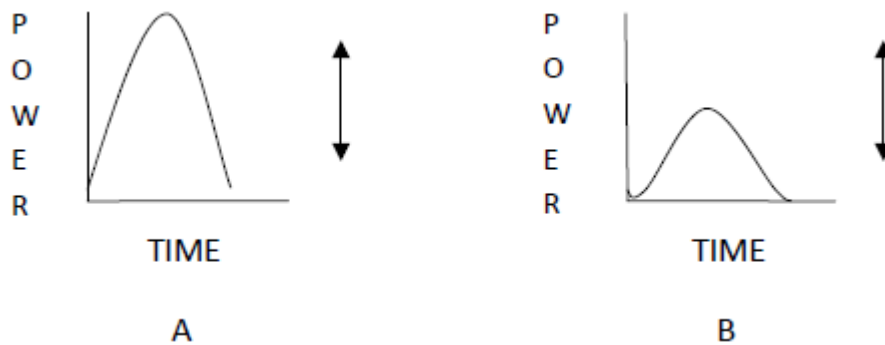

“A” has the greatest power because the peak power is greater.

FIG. 1-7  
Peak Power

### C. Output power

The output wavelength defines the portion of the optical spectrum in which the laser operates.

1. Ultraviolet- 100nm-400nm
2. Visible-400nm-760nm
3. Infrared-760nm-10,000nm

The output power is expressed in watts or milliwatts. The greater the wattage is, the greater the power; therefore, the greater the danger.

## Types of Lasers

There are several different types of lasers. The differences depend on the type of active medium used. The active medium can be:

- A. Gas
- B. Solid
- C. Semiconductor
- D. Dye

### A. Gas Lasers

Gas lasers use gas as the active medium (FIG. 1-8). Excitation is achieved by a current flowing through a gas filled tube. These lasers can be continuous wave or pulsed. Examples of gas lasers are HeNe, Argon and CO<sub>2</sub>. These lasers can be used for welding and cutting, eye surgery and entertainment.

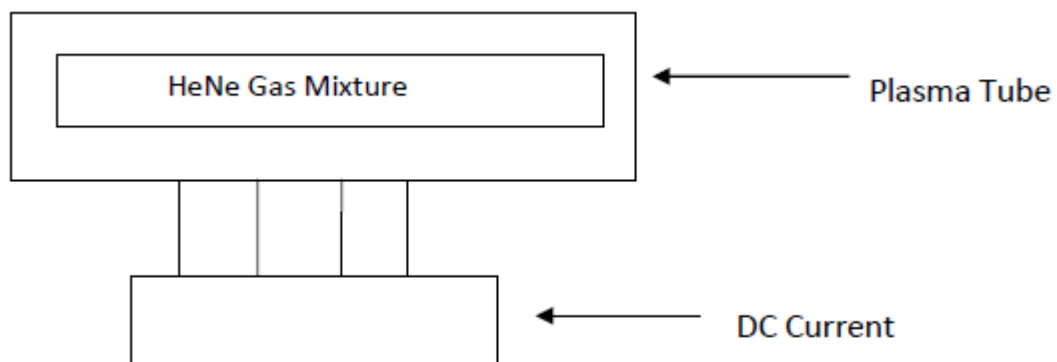

FIG. 1-8

Gas Laser

## B. Solid Lasers

Solid lasers use a solid crystal or glass as the active medium (FIG.1-9). The excitation energy comes from pumping a flash lamp or light. Examples of solid laser are Ruby and Neodymium:YAG. Solid lasers are used for measuring, eye surgery and hole drilling.

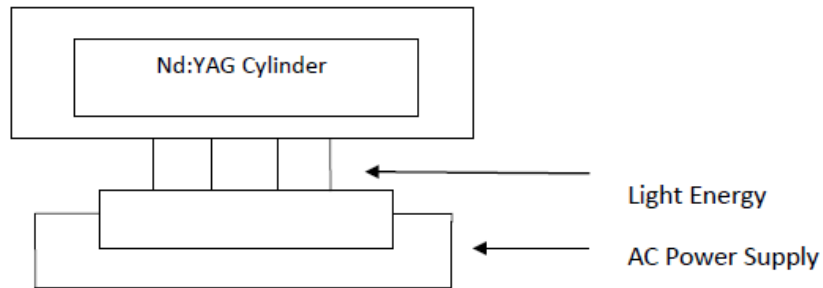

FIG. 1-9

Solid Laser

## C. Semiconductor Lasers

Semiconductor lasers use a junction between two types of semiconductor materials. A semiconductor is a material whose conductivity is greater than that of an insulator but less than a good conductor such as copper. The excitation mechanism is a current that flows between two semiconductors that have been joined together. An example of a semiconductor laser is GaAs-Gallium Arsenide. A distinguishing characteristic of semiconductor lasers is their extremely small size. They are about the size of a grain of sand. These lasers are used in precision measuring and communications.

#### **D. Dye Lasers**

Organic dye lasers use dyes dissolved in alcohol as the active medium. Some use rhodamin6G and some use fluorescein. The dye solution is circulated by a pump through a glass or quartz tube. The excitation mechanism is a pulse of light from a flashlamp or another laser. A distinguishing feature of dye lasers is that they can be “tuned” to a particular wavelength by changing the concentration of the dye solution so a larger range of wavelengths can be obtained. These lasers are used in spectroscopy and special photography.

## **Laser Classification System**

**Class 1-(.39mw)**- This class is eye-safe under all operating conditions.

**Class 1M**-This class is safe for viewing directly with the naked eye, but may be hazardous to view with the aid of optical instruments. In general, the use of magnifying glasses increases the hazard from a widely-diverging beam (e.g. LEDs and bare laser diodes), and binoculars or telescopes increase the hazard from a wide, collimated beam (such as those used in open-beam telecommunications systems).

Radiation in classes 1 and 1M can be visible, invisible or both.

**Class 2- (<1mw)**- These are visible lasers. This class is safe for accidental viewing under all operating conditions. However, it may not be safe for a person who deliberately stares into the laser beam for longer than 0.25 s, by overcoming their natural aversion response to the very bright light.

**Class 2M**-These are visible lasers. This class is safe for accidental viewing with the naked eye, as long as the natural aversion response is not overcome as with Class 2, but may be hazardous (even for accidental viewing) when viewed with the aid of optical instruments, as with class 1M.

Radiation in classes 2 and 2M is visible, but can also contain an invisible element, subject to certain conditions.

Classes 1M and 2M broadly replace the old class 3A under IEC and EN classification. Prior to the 2001 amendment there were also lasers which were Class 3B but were eye-safe when viewed without optical instruments. These lasers are Class 1M or 2M under the current Classification system.

**Class 3R**-Radiation in this class is considered low risk, but potentially hazardous. The class limit for 3R is 5x the applicable class limit for Class 1 (for invisible radiation) or class 2 (for visible radiation). Hence CW visible lasers emitting between 1 and 5 mW are normally Class 3R. Visible class 3R is similar to class IIIA in the US regulations.

**Class 3B- (<500mw)**- Radiation in this class is very likely to be dangerous. For a continuous wave laser, the maximum output into the eye must not exceed 500mW. The radiation can be a hazard to the eye or skin. However, viewing of the diffuse reflection is safe.

**Class 4-(>500mw)**-This is the highest class of laser radiation. Radiation in this class is very dangerous, and viewing of the diffuse reflection may be dangerous. Class 4 laser beams are capable of setting fire to materials onto which they are projected.



## Lesson 2: Light and Optics

### Light Waves in the Electromagnetic Spectrum

Electromagnetic radiation (EM) consists of electrical energy and magnetic energy which travel together through space as waves. Visible light is EM radiation but there are also many types of invisible EM radiation. Examples include radio waves, TV signals and microwaves.

The different types of EM radiation are identified by wavelengths. Radio waves are longer than other forms and x-rays and gamma rays are the shortest.

In studying laser light, we are most concerned with the optical spectrum region of the EM spectrum. This includes infrared, ultraviolet and visible light. Most lasers operate in one or more of these wavelength regions.

- A. Infrared (IR)-760nm-10,000nm; slightly longer than the red end of the visible spectrum. It is emitted by all “hot” bodies or objects that emit heat.
  - a. **Infrared A (IRA)**-760nm-1400nm
  - b. **Infrared B (IRB)**-1400nm-3000nm
  - c. **Infrared C (IRC)**-3000nm-10,000nm
  
- B. Visible-400nm-760nm; region of EM spectrum known as light
  
- C. Ultraviolet (UV)-100nm-400nm; very energetic; more so than visible and infrared.
  - a. **Ultraviolet A (UVA)**-320nm-400nm
  - b. **Ultraviolet B (UVB)**-280nm-320nm
  - c. **Ultraviolet C (UVC)**-100nm-280nm

### How Light Interacts With Materials

When light strikes a material, it can be scattered, absorbed, reflected or transmitted. Usually all four things happen. Transmission is the only interaction that may not occur. One thing to note is none of the light is lost. Energy striking the material equals energy used up due to the law of energy conservation.

## Reflection and Mirrors

Some reflection occurs when light interacts with the surface of a material. These surfaces can be smooth or rough, plane or curved.

When light is reflected off a surface, the light rays strike the surface and bounce off the surface at equal angles. According to the Law of Reflection, the angle of incidence always equals the angle of reflection.

- A. Diffuse reflections occur when light reflects off of rough surfaces (FIG.2-1). These surfaces reflect light in random patterns because each surface acts as a reflector. Each time light interacts, the law of reflection is observed. When laser light interacts with diffuse reflectors, it is scattered greatly and loses its intensity.

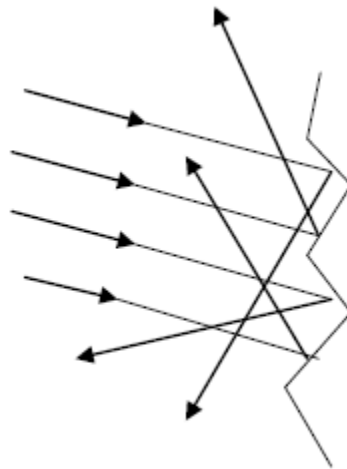

FIG. 2-1  
Diffuse Reflector

- B. Specular reflections occur when light is reflected from smooth, shiny surfaces such as a mirror (FIG.2-2). Specular reflectors are flat or curved. Damage to the eye from flat, specular reflectors can be as hazardous as if you had stared directly into the beam. Very little intensity is lost.

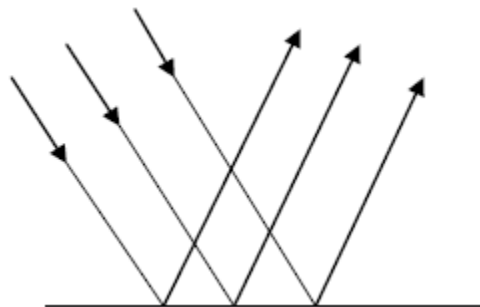
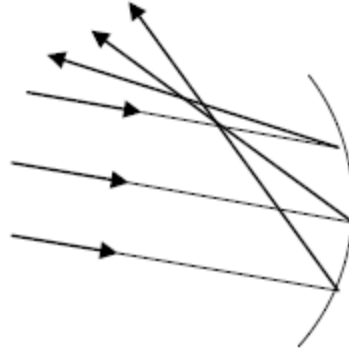

FIG. 2-2  
Plane Specular Reflector

When light strikes a curved, specular reflector (FIG.2-3), different rays in the beam are reflected at different angles but always obey the law of reflection.

FIG.2-3  
Curved Specular  
Reflector



C. Mirrors reflect all the light that strikes them. When light strikes a plane mirror, it leaves as a parallel beam of light.

When light strikes a concave mirror (FIG.2-4), the light is reflected back to a focal point where the power of the beam is concentrated into a very small area.

FIG. 2-4  
Laser Light on  
Concave Mirror

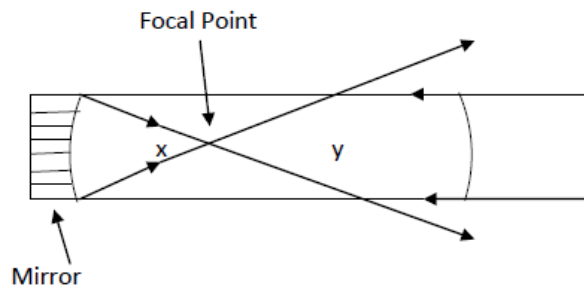

When light strikes a convex mirror (FIG. 2-5), it is again reflected back but this time the rays diverge making the beam less hazardous as it spreads out.

FIG. 2-5  
Laser Light On  
Convex Mirror

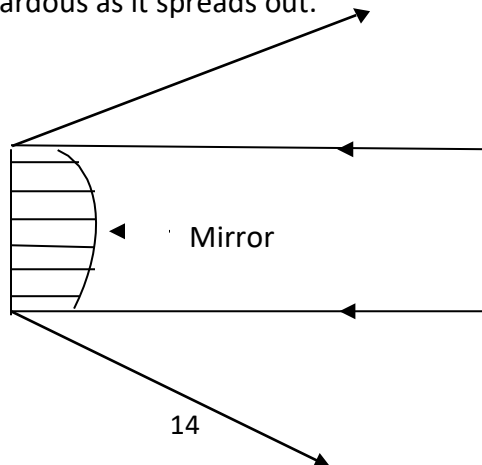

## Refraction of Transmitted Light: Lenses

Refraction occurs when light changes direction as it travels from one material to another. It is refracted either away from or towards a line perpendicular to the surface called the normal.

- A. Converging lenses are thicker in the center than at the edges (FIG. 2-6). When light strikes a converging lens it is refracted to a point on the other side and then spreads out again. The intensity is increased at the point where the beam converges.

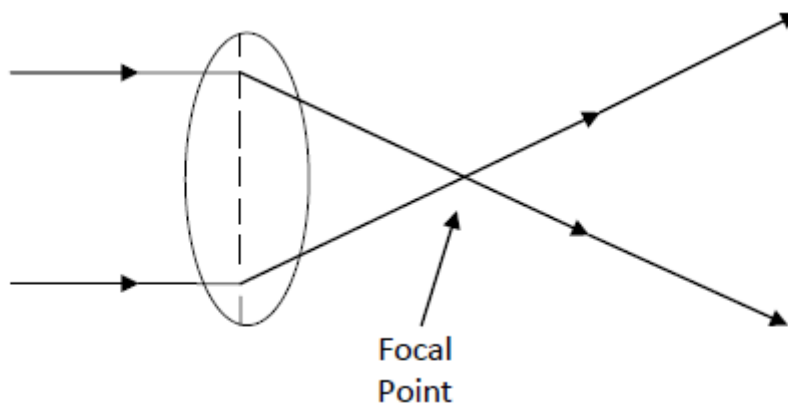

FIG. 2-6  
Converging Lens

- B. Diverging lenses are thicker at the edges than in the middle (FIG. 2-7). When light strikes this type of lens, the beam spreads out and the intensity decreases.

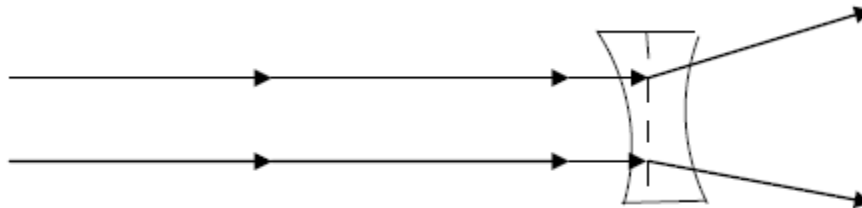

FIG. 2-7  
Diverging Lens

## Absorption of Transmitted Light: Filters and Laser Eyewear

Filters are based on the absorption of light. Examples of filters are sunglasses and tinted car windows. The filters work by absorbing or reflecting some of the light so it is not transmitted.

Laser eyewear works the same way. Most filters fall into one of three groups.

- A. Neutral density filters absorb and/or reflect light over a wide range of wavelengths. (FIG. 2-8)

FIG. 2-8  
Neutral Density Filter

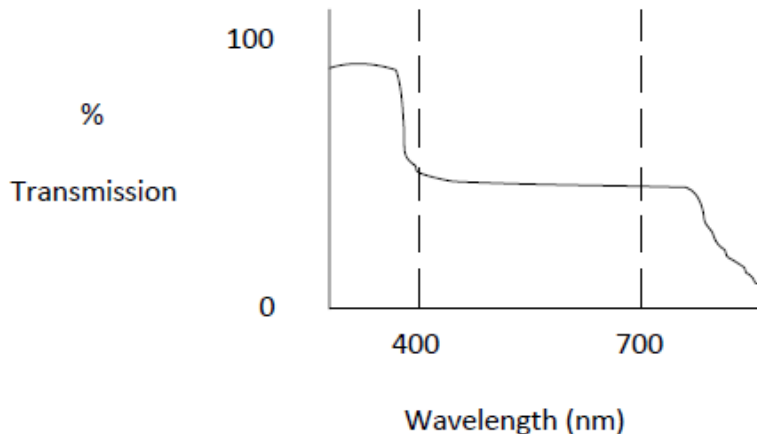

- B. Cut-off filters transmit light at one end of the optical spectrum but not the other. (FIG. 2-9)

FIG. 2-9  
Cut Off Filters

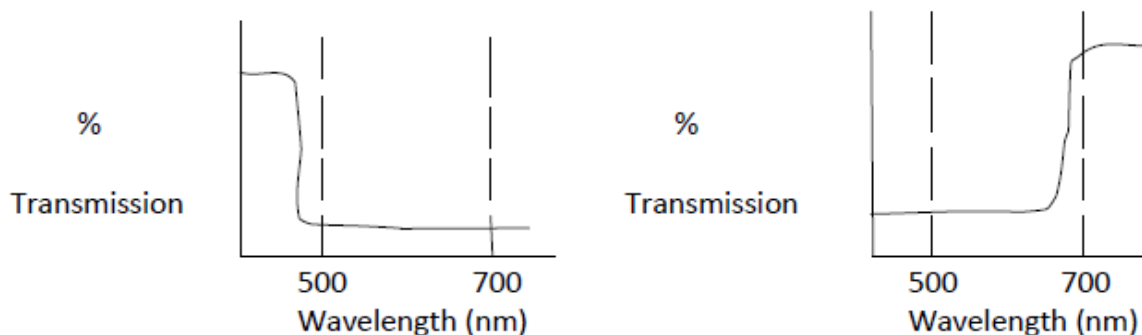

- C. Bandpass filters transmit light in a very narrow range of wavelengths and block all other wavelengths. (FIG.-2-10)

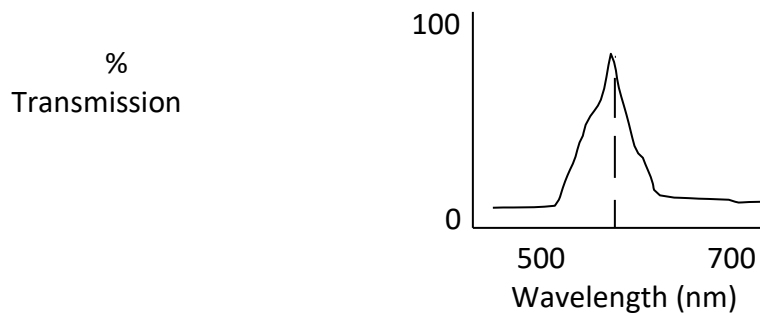

FIG. 2-10  
Bandpass Filter

**Optical Density (OD)** is a number used to describe filters. It indicates the filters capacity to block. It is the opposite of transmission. A high optical density allows very little transmission.

100% transmission=0 OD

**\*\*\*\*\*REMEMBER\*\*\*\*\***

Eyewear that works at one wavelength MAY NOT work at another and some filters that work by reflection increase the hazard to bystanders.

***BEFORE LASER SAFETY EYEWEAR CAN WORK, IT MUST BE WORN!!!!***

## Light Measurements for Laser Safety

Radiometry is the science of detecting and measuring EM radiation. There are many different radiometric units but the four most important are:

- A. Radiant energy
- B. Radiant power
- C. Irradiance
- D. Radiant exposure

Output beams of lasers are measured in terms of radiant energy or **radiant power**.

**Radiant energy** is the amount of energy traveling through space in the form of light waves. It is measured in **joules**.

**Radiant power** is the amount of energy transferred in a given amount of time. It is measured in **watts (joules/sec)**. This is the total amount of power contained in a laser beam regardless of the size of the beam. Increasing or decreasing the beam diameter has no effect on the radiant power. A given amount of energy delivered in a short period of time represents more power than the same amount of energy delivered over a longer period of time. Time is critical in determining laser hazard.

The beam intensity is called the **irradiance**. This is the amount of power concentrated in a certain area. It is measured in **W/cm<sup>2</sup>**. The size of the area where the laser is concentrated makes a great difference on the impact of the power delivered. The more concentrated the light, the greater its impact. The smaller the laser beam size, the more power per unit area and the higher the irradiance. Continuous wave lasers deliver energy at a steady rate and are described by irradiance.

**Radiant exposure** is the total energy radiated over a given area. It is measured in J/cm<sup>2</sup> and used to describe pulsed lasers because energy is not delivered at a constant rate.

## Lesson 3: LASER HAZARDS

Laser light can be absorbed by body tissue. If the beam is powerful enough, the absorbed energy can cause injury. The skin and eyes are the most sensitive tissue to laser light.

The amount of light absorbed depends on the wavelength of the beam. The more light absorbed, the greater the injury.

In studying lasers, we are concerned with the optical spectrum of the EM spectrum. The wavelength range is 100nm-10000nm. Again, the optical spectrum includes ultraviolet, visible and infrared light.

### Laser Damage in Human tissue

Laser light can cause four harmful effects to tissue.

- A. Thermal Effects- Thermal damage or the burning of tissue is the major cause of laser damage. The degree of burning varies according to absorbency of the tissue and depends on the power output, size of the irradiated area, duration of the exposure and the repetition rate or number of pulses.
- B. Acoustic Transients-Acoustic transients are related to thermal effects. The tissue vaporizes and explodes causing a shockwave to occur in surrounding tissue. In some cases, the tissue actually ruptures.
- C. Photochemical Effects- Photochemical effects occur when the light interacts with the cell, changing its chemistry. This may prevent normal cell function.
- D. Chronic Effects-Chronic effects include premature aging of the skin, skin cancer and cataracts. They are due to frequent and regular exposure over a long period of time.



## Eye Injuries

Injuries to the eye occur at much lower powers than injuries to the skin. Eye injuries are more likely to have permanent effects including reduced vision or blindness.

### A. Parts of the Eye

1. Cornea- outer layer of eye; withstands mild assaults and heals quickly, usually within 24 hours.
2. Lens- flexible tissue that changes shape. It focuses light to the back of the eye.
3. Iris- controls the amount of light entering the eye.
4. Pupil- opening in the center of the eye through which light passes. The size changes in different light conditions.
5. Retina- light sensitive area at back of eye. The lens focuses the image on the retina that sends electrical signals to the brain.
6. Fovea- most sensitive part of the retina. It is responsible for detailed vision.

Visible and near infrared radiation are absorbed chiefly by the retina and the fovea. They make up the retinal hazard region of the optical spectrum. The retina can undergo thermal, photochemical and acoustic effects. Blind spots can occur.

Irradiance is partly dependent on the pupil size. The size of the pupil determines the amount of laser light entering the eye. It is best to work in well lit areas so the pupil size is small.

### B. Exposure Duration

Exposure duration affects retinal injury. Short CW exposures of <10 seconds and >1 usec will cause thermal injury. The injuries occur when energy is absorbed faster than it is removed. Exposure of <1 usec will cause acoustic injuries. The heat causes the irradiated area to expand and tear.

Long, low, intense exposures cause photochemical damage.

### **C. Other Effects**

Ultraviolet A (UVA) and infrared A (IRA) are absorbed by the lens which then undergoes photochemical damage. UVA causes cataracts and premature aging of the lens and IRA causes cataracts.

Infrared B (IRB), infrared C (IRC), ultraviolet B (UVB), and ultraviolet C (UVC) affect the cornea. UVB and UVC cause conjunctivitis, a condition which usually lasts about 48 hours and causes the eyes to feel like they have sand in them and produce a lot of tears.

When absorbed deep into the cornea, UVB and UVC cause milky cornea. This occurs within 6-12 hours.

IRB and IRC cause cataracts and flash burns. Infrared waves transmit thermal energy and some heat may be transferred to the iris and lens.

### **Skin Injuries**

The risk of skin injury is considered secondary to the risk of eyes because the effects are not as severe. Usually, large areas of the skin are not exposed. Because the beam is small, the affected area is small.

#### **A. The Epidermis and the Dermis**

The epidermis is the surface layer of the skin and the dermis is the underlying layer of the skin. Melanin pigment granules are located in the epidermal layer of the skin. They travel to the surface to protect against UV light. As they absorb radiation, they darken and produce a suntan.

The dermal layer contains specialized cell and glands, blood vessels and nerves.

Visible light and IRA are reflected by the skin. UVB, UVC, IRB and IRC are greatly absorbed by the skin. The skin and the cornea of the eye react similarly.

Sunburns occur from exposure to UVB and UVC. Melanin granules absorb the radiations and travel to the skin's surface causing reddening and eventual tanning. Exposure to UV radiation is known to cause premature aging and increases the risk of skin cancer.

IRB and IRC cause skin burns. Visible light and IRA can also cause burns but only at much higher irradiances.

## Hazardous Levels of Laser Exposure

Whether or not a laser will cause injury depends on:

- A. Irradiance
- B. Wavelength
- C. Exposure time

The wavelength and exposure time are generally known and charts can be used to determine the irradiance of the maximum laser exposure that can be received without any risk.

The **maximum permissible exposure (MPE)** limits have been set by the American National Standards Institute (ANSI). The MPE is the greatest amount of exposure most people can tolerate without injury. The MPE is expressed by radiation exposure ( $J/cm^2$ ) or irradiance ( $W/cm^2$ ) and is linked to the wavelength and the exposure time.

Usually, the hazard classification system is used to determine the hazard. Remember, lasers are classified according to the degree of hazard they pose. There are Class I- Class IV lasers.

## Related Hazards

### A. Electric shock is the most dangerous related hazard

1. Some basic rules of electrical safety follow:
  - a. Become familiar with the procedure for the disconnecting equipment. Label clearly the means of disconnection.
  - b. Never handle electrical equipment when any part of the body or clothing is wet or when standing on a wet floor.
  - c. With high voltages, consider all floors conductive and grounded unless they are covered with suitable, dry matting.
  - d. Whenever possible, use only one hand when working on circuits or control devices.
  - e. To avoid freezing to the conductor in case shock occurs, use the back of the hand when touching electrical equipment, if possible.
  - f. Avoid wearing metallic watchbands, rings or other metal jewelry when working with or in the area of electrical equipment.
  - g. Provide overhead runways for extension cords and other plug-in receptacles to keep all electrical leads above floor level and out of walkways.
  - h. Learn the rescue procedures for helping a victim of electrocution:
    1. Kill the circuit.
    2. Remove the victim with a non conductor if he is still in contact with the circuit.
    3. Initiate resuscitation.
    4. Have someone call for EMS.

## **B. Hazardous Materials**

Some hazardous materials used with the lasers are toxic and flammable

Hazardous materials can be found in the active medium, can be produced by the laser interacting with the target or be used in cleaning and maintenance.

## **C. Fire Hazards**

High powered, continuous wave lasers present fire hazards. Reflection and direct beams can ignite flammable materials near the laser. When possible, use non-volatile materials in place of the volatile ones.

# Lesson 4: Laser Safety Practices and Controls

## Safety Controls

### A. Engineering controls

Engineering controls are design features applied to the laser or laser environment. They restrict exposure or reduce irradiance. These are the most effective but most expensive controls. Some engineering controls include:

1. Remote firing
2. Key switches
3. Warning buzzers/lights
4. Protective housings
5. Beam attenuators
6. Beam stops
7. Door interlocks
8. Viewing windows
9. Controlled areas
10. Shutters
11. Controlled beam paths
12. Beam enclosures

### B. Administrative Controls

Administrative controls are procedures and information rather than devices. These are usually implemented by the laser safety office (LSO). The LSO should be knowledgeable in evaluating and controlling laser hazards.

Administrative controls include:

1. Standard operating procedures (SOP's)
2. Administrative procedures
3. Warning signs

Standard operating procedures (SOP's) should cover start-up, shut down, emergency situations and specific operations such as alignment.

Administrative procedures include having operating manuals available, making sure eyewear is properly marked, developing education and training and maintenance.

Warning signs are designed according to the hazard classification. "Caution" signs are used with Class II and IIIA laser and "Danger" signs are used with Class IIIB and Class IV lasers.

Each classification (except Class I) has a certain label which must be placed on the laser product and corresponds to the type of hazard associated with the laser (FIG. 4-1-4-4).

FIG. 4-1

Class II Laser Product

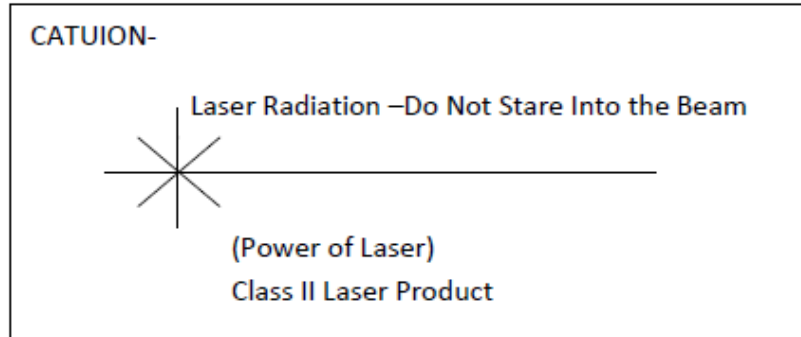

FIG. 4-2

Class IIIA Laser Product

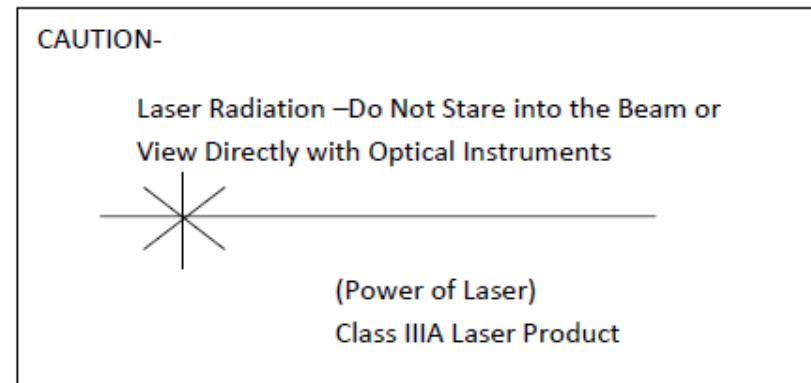

Fig.4-3

Class IIIB Laser Product

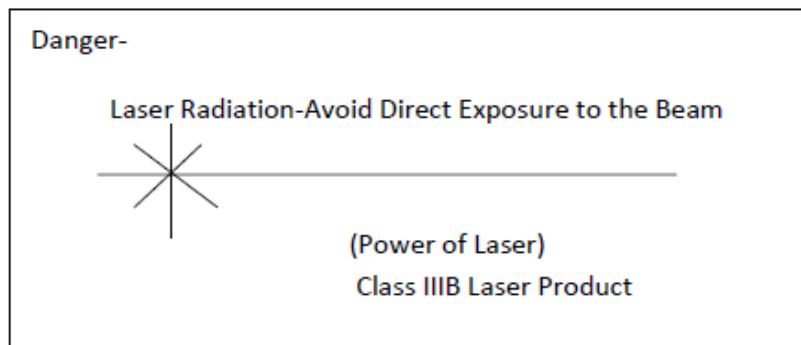
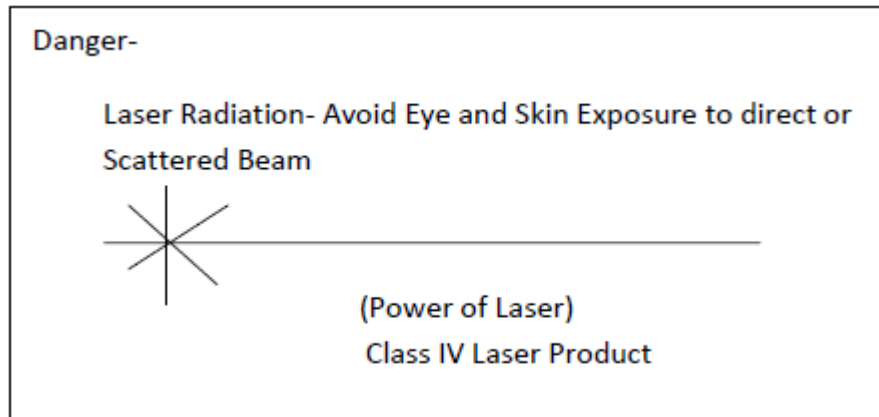

Fig.4-4

Class IV  
Laser  
Product



There are other labels which need to be placed on the lasers.

1. Aperture Labels-are used on Class IIIA, III B and IV laser products.
  - a. Avoid Exposure-Laser Radiation Emitted from this Aperture.
  - b. Avoid Exposure- Hazardous Electromagnetic Radiation is Emitted from this Aperture
  - c. Avoid Exposure-Hazardous X-rays Emitted from this Aperture.
  
2. Non Interlocked Protective Housing Labels

Class II

Caution- Laser Radiation When Open. Do Not Stare into Beam.

Class IIIA

Caution-Laser Radiation When Open. Do Not Sate Into Beam or View Directly with Optical Instruments.

Class IIIB

Danger- Laser Radiation When Open. Avoid Direct Exposure to Beam.

Class IV

Danger- Laser Radiation When Open. Avoid Eye and Skin Exposure to Direct and Scattered Radiation.

### 3. Defeatably Interlocked Protective Housing Labels

#### Class II

Caution- Laser Radiation When Open and Interlock Defeated. Do Not Stare into Beam.

#### Class IIIA

Caution- Laser Radiation When Open and Interlock Defeated. Do Not Sate Into Beam or View Directly with Optical Instruments.

#### Class IIIB

Danger- Laser Radiation When Open and Interlock Defeated. Avoid Direct Exposure to Beam.

#### Class IV

Danger- Laser Radiation When Open and interlock Defeated. Avoid Eye and Skin Exposure to Direct and Scattered Radiation.

### C. Personnel Protective Equipment

Personnel Protective equipment includes clothing, gloves and laser eyewear. Eyewear is the most important type of protective equipment available. It must be selected for the system with which it is being used.

Selection of eyewear depends on several factors:

1. Wavelength-The eyewear must be able to attenuate or filter all wavelengths associated with the laser.
2. Optical density-The optical density at the specific wavelength must be marked on the eyewear.
3. Luminous transmittance-The luminous transmittance is the degree to which you can see through the eyewear. Most eyewear has luminous transmittance values of 10%- 70 %.
4. Damage to the eyewear-Eyewear damage can occur from melting, bleaching or shattering and therefore the eyewear should be routinely inspected.
5. Hazards of the eyewear-Some eyewear can cause dangerous reflections.
6. Comfort and wearability-This is one of the most important criteria when choosing eyewear. If the eyewear is not comfortable, chances are great that it will not be won.



## **Hazard Classification and Corresponding Controls**

Control measures are correlated to the hazard classification of the laser. Certain control measures are associated with each class of laser.

### **A. Class I-Exempt**

This includes enclosed lasers and lasers that can cause no injuries even if the beam is collected by optical instruments and concentrated into the eye. They are exempt also because they are enclosed and the enclosure is removable only with the aid of tools.

### **B. Class II**

Visible lasers that are not hazardous when viewed accidentally due to the natural aversion response. They may cause harm if stared at for a long period of time. The caution label must be affixed and the following rules should be followed.

1. Never permit a person to stare continuously into the beam.
2. Never direct the beam into a person's eye.

### **C. Class III**

This includes those lasers which can cause injury only if the beam is collected with optical instruments and directed into the eye (IIIA) and those lasers that can cause injury when viewed by the unaided eye (IIIB). The "Caution" label must be affixed to IIIA lasers and the "Danger" label must be affixed to the IIIB laser. Other controls include:

1. Enclosing the beam path.
2. Terminating the beam path.
3. Arranging the laser so that the beam path is not at eye level.
4. Mounting the laser on firm support.
5. Eliminating specular surfaces from the beam path.
6. Operating the laser in controlled areas, with interlocks for IIIB lasers.
7. Installing beam shutters and filters to reduce the beam power to less hazardous levels for IIIB lasers.
8. Providing key switches for IIIB lasers.
9. Installing warning lights or buzzers for IIIB lasers.
10. Posting warning signs.

#### **D. Class IV**

This includes those lasers which can cause injury from direct exposure and diffuse or specular reflections. All control measures for Class III lasers apply to Class IV lasers and also the following may apply:

1. Light tight rooms
2. Remote firing and viewing
3. Fire resistant targets and backstops

### **Hazard Evaluation**

#### **A. Hazards Associated with Laser Equipment**

1. Bypassing the interlock system for maintenance or repair work and failure to restore the interlock system when work is finished.
2. Accidental activation of power supplies while workers are in a position to receive electrical shock or laser beam exposure.
3. Accidental laser firing through unexpected capacitor discharge or unintentional closing of the firing switch
4. Alteration of the beam path by physically moving the laser or the tripod or table upon which it is mounted.

#### **B. Hazards Associated with the Laser Environment:**

1. Mechanical damage to beam enclosure
2. Removal of enclosures, baffles, safety screens or beam blocks to align the beam
3. Addition of optical components within the beam path without controlling the reflections.
4. Presence in the beam path of specularly reflecting and diffusely reflecting materials
5. Interactions of high power beams with flammable material

## **Control Measures**

### **A. Work Area Controls**

1. The laser should be used away from areas where the uninformed and the curious would be attracted by its operation.
2. The illumination in the area should be as bright as possible in order to constrict the pupils of the observers.
3. The laser should be set up so that the beam path is not at normal eye level.
4. Shields should be used to prevent both strong reflections and the direct beam from going beyond the area needed for the demonstration or experiment.
5. The target of the beam should be diffuse, absorbing material to prevent reflection.
6. Remove all watches and rings before changing or altering the experimental setup. Shiny jewelry could cause a hazardous reflection.
7. All exposed wiring and glass on laser should be covered with a shield to prevent shock and contain any explosions of the laser materials. All non-energized parts of the equipment should be grounded.
8. Signs indicating that the laser is in operation and that it may be hazardous should be placed in conspicuous locations both inside and outside the work area and on doors giving access to the area.
9. The laser should never be left unattended while in operation.
10. Good housekeeping should be practiced to insure that no device, tool or other reflective material is left in the path of the beam.
11. A detailed operating procedure should be outlined beforehand for use during laser operation. Emergency procedures should also be available.
12. Whenever a laser is operated outside the visible range, some warning device must be installed to indicate its operation.
13. A key switch to lock the high voltage supply should be installed.

### **B. Personnel Controls**

1. Avoid looking into the primary beam at all times.
2. Do not aim the laser with the eye. Direct reflections could cause retinal burns.
3. Do not look at reflections as they may cause retinal burns.
4. Avoid looking at the pump source.
5. Clear all personnel from the anticipated path of the beam.
6. Do not depend on sunglasses to protect the eyes. When laser safety goggles are worn, be certain they are designed for the specific laser being used.
7. Report any after image to a doctor, preferably an ophthalmologist who has had experience with retinal burns, as damage may have occurred.
8. Be very cautious around lasers which operate in the invisible light frequencies.
9. Before operation, warn all personnel and visitors of the potential hazard.

## **Safety Standards**

Standards used today include those developed by the American National Standards Institute (ANSI), American Conference of Governmental Industrial Hygienists (ACGIH), National Center for Devices and Radiological Health (NCDRH) and Occupational Health and Safety Act (OSHA). ANSI and ACGIH developed guidelines which are only voluntary where as the standards developed by OSHA and NCDRH are legally enacted and compliance with them is mandatory. The difference between ANSI, ACGIH and OSHA, NCDRH is that the former are developed by responsible professionals in the field who are attempting to make the industry safety for the worker. They are concerned with the amount of exposure and address safety limits. They are directed to the user. The latter are developed by governmental agencies. They are concerned with the amount of radiation emitted from the source so they impose restrictions on the manufacturer.

Most organizations using lasers today base their training and control programs on the ANSI standards.

## **Employer/Employee Responsibilities**

Based on the ANSI standards, there are definite responsibilities placed on the employer as well as the employee.

### **A. Employer Responsibilities**

1. The employer must insure the safe use of all lasers by maintaining a laser safety program. The laser safety program should include:
  - a. Delegation of responsibility for laser hazard evaluation to a laser safety officer (LSO).
  - b. Education and training of authorized users.
  - c. Evaluating control measures.
  - d. Management of necessary record keeping including accident reporting, laser registration, training and reviewing SOP's.

### **B. Employee Responsibilities**

1. You must be authorized to use the laser or to be in the area of the laser.
2. Recognize hazards.
3. Adhere to safety rules and procedures.
4. Respect all control measures including the wearing of safety goggles at all times when it is necessary and practical.

5. Comply with the medical surveillance program.

The medical surveillance program is overseen by the Environmental Health and Safety staff and includes a base line eye exam. There is also an eye exam required when employment is terminated.

6. Reporting all accidents or suspected accidents to:

Radiation Safety Office  
306 Benson School  
Phone: 777-5269 or USC Police at 777-4215

## References

Information in this manual was compiled by the University of South Carolina, Office of Radiation Safety using the following material as references.

1. American National Standards Institute, Inc., American National Standard For The Safe Use of Lasers, Z136.1-2007, The Laser Institute of America, 1986.
2. Dosimeter Corporation, Laser Safety Concepts, Hazard Analysis and Measurement, Dosimeter Corporation, 1983.
3. Engineering Technology Institute, Safety Course for Laser Personnel, ETI, 1983.
4. Engineering Technology Institute, Computer Based Training in Laser Safety, ETI, 1988.
5. U.S. Department of Health, Education, and Welfare, Public Health Service, Environmental Health Service, Laser Fundamentals and Experiments, Bureau of Radiological Health, 1970.